

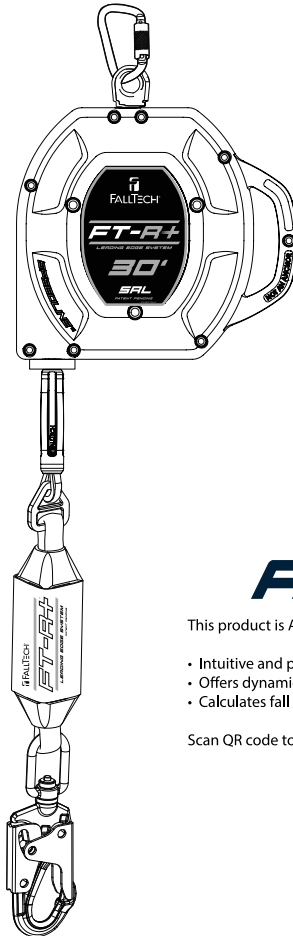

## User Instruction Manual

### FT-R+® Class 2 Leading Edge SRL



This product is AXIS™ enabled.

- Intuitive and precise fall clearance calculator
- Offers dynamic 3D representation for accurate assessments
- Calculates fall clearance specific to this product

Scan QR code to try AXIS for streamlined safety compliance.



This manual is intended to meet the Manufacturer's Instructions as required by the American National Standards Institute (ANSI) Z359 and Canadian Standards Association (CSA) Z259 and should be used as part of an employee training program as required by the Occupational Safety and Health Administration (OSHA).

FallTech © 2025

1306 South Alameda Street Compton, CA 90221, USA

1-800-719-4619 • 1-323-752-0066

[www.FallTech.com](http://www.FallTech.com)

## Table of Contents

1.0 Warnings and Important Information .....	3
2.0 Description .....	4
3.0 Application .....	6
4.0 System Requirements.....	7
5.0 Installation and Use .....	9
6.0 Maintenance, Service, and Storage.....	16
7.0 Inspection.....	22
8.0 Labels.....	25
9.0 Definitions .....	26

For the purposes of this manual, the FallTech® FT-R+® Class 2 Leading Edge SRL in all iterations may be referred to collectively as the FT-R+, the FT-R+ SRL, the SRL-LE, the SRD Leading Edge (SRD-LE), the leading edge SRL, the Class 2 SRL, the self-retracting device (SRD), the self-retracting lifeline (SRL), the equipment, the device, the product, or the unit.

Throughout this manual, ANSI Z359.0-2012 fall protection words, phrases, and terms are used. These terms are all formally defined in Section 9 of this manual.

Any non-English translations of this user instruction manual are for reference only.

 **WARNING**

- Avoid moving machinery, thermal, electrical, and/or chemical hazards as contact may cause serious injury or death.
- Avoid swing falls.
- Follow the weight restrictions and recommendations in this manual.
- Remove from service any equipment subjected to fall arrest forces.
- Remove from service any equipment that fails inspection.
- Do not alter or intentionally misuse this equipment.
- Consult FallTech when using this equipment in combination with components or subsystems other than those described in this manual.
- Do not connect rebar hooks, large carabiners, or large snap hooks to the FBH dorsal D-rings as this may cause a roll-out condition and/or unintentional disengagement.
- Avoid sharp and/or abrasive surfaces and edges.
- Use caution when performing arc welding. Arc flash from arc welding operations, including accidental arcs from electrical equipment, can damage equipment and are potentially fatal.
- Examine the work area. Be aware of the surroundings and workplace hazards that may impact safety, security, and the functioning of fall arrest systems and components.
- Hazards may include but not be limited to cable or debris tripping hazards, equipment failures, personnel mistakes, moving equipment such as carts, barrows, fork lifts, cranes, or dollies. Do not allow materials, tools or equipment in transit to contact any part of the fall arrest system.
- Do not work under suspended loads.

 **IMPORTANT**

## 1.0 Warnings and Important Information

This product is part of a personal fall arrest, restraint, work positioning, suspension, or rescue system. A Personal Fall Arrest System (PFAS) is typically composed of an anchorage and a Full Body Harness (FBH), with a connecting device, i.e., a Energy Absorbing Lanyard (EAL), or a Self-Retracting Device (SRD), attached to the dorsal D-ring of the FBH.

These instructions must be provided to the worker using this equipment. The worker must read and understand the manufacturer's instructions for each component or part of the complete system. Manufacturer's instructions must be followed for proper use, care, and maintenance of this product. These instructions must be retained and be kept available for the worker's reference at all times. Alterations or misuse of this product, or failure to follow instructions, may result in serious injury or death.

A Fall Protection Plan must be on file and available for review by all workers. It is the responsibility of the worker and the purchaser of this equipment to assure that users of this equipment are properly trained in its use, maintenance, and storage. Training must be repeated at regular intervals. Training must not subject the trainee to fall hazards.

Consult a doctor if there is reason to doubt your fitness to safely absorb the shock of a fall event. Age and fitness seriously affect a worker's ability to withstand falls. Pregnant women or minors must not use this equipment.

ANSI limits the weight of fall protection equipment users to a maximum of 310 lbs. Products in this manual may have a rated capacity exceeding ANSI capacity limits. Heavy users experience more risk of serious injury or death due to falls because of increased fall arrest forces placed on the user's body. In addition, the onset of suspension trauma after a fall even may be accelerated for heavy users.

The user of the equipment discussed in this manual must read and understand the entire manual before beginning work.

**NOTE:** For more information consult the ANSI Z359 or CSA Z259 body of standards.

## 2.0 Description

The FallTech® FT-R+® Leading Edge SRL is a self-retracting device for those working at height and may be subject to Leading Edge fall hazards, see Figure 6 for typical extreme sharp edges.

This manual contains one Appendix that contains figures and tables specific to the FT-R+ Leading Edge SRL discussed in this manual.

The SRL discussed in this manual may be attached to an overhead anchorage, i.e., from directly over the user's head, to as low as the level of the user's FBH dorsal D-ring. The SRD may also be attached to a non-overhead anchorage, i.e., level with the user's FBH dorsal D-ring, down to a maximum of 5' below the user's FBH dorsal D-ring (foot level).

Leading edge means the unprotected side and edge of a floor, roof, or form work for a floor or other walking/working surface (such as deck) which changes location as additional floor, roof, decking or form work sections are placed, formed or constructed. The shape and texture of a leading edge may vary, see Figure 6.

As shown in Figure 1 below, the SRD has a glass reinforced nylon housing with an integrated handle that contains a lifeline composed of 7/32" (5.6mm) diameter galvanized steel wire rope, wound onto a spring tensioned drum. The SRD's lifeline is equipped with a cable stop/handle assembly with a bumper, integrated tearaway Energy Absorber (EA), and a steel swivel snaphook. When the user is attached, the lifeline extends and retracts with user movement, automatically maintaining a taut lifeline. If a fall occurs, a centrifugal pawl system engages, stopping the lifeline payout. The tearaway EA deploys, gradually slowing and arresting the fall.

See Table 1A in Appendix A for product and materials specifications.

The FT-R+ SRLs discussed in this manual feature SpeedLine™ field replaceable lifeline technology. See Section 6 for more information and requirements.

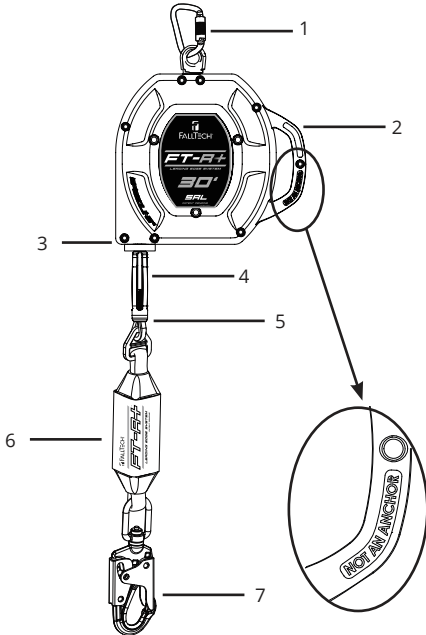

Figure 1 - About FallTech® FT-R+ Leading Edge SRL	
1	Anchorage Connecting Carabiner
2	Carrying Handle (Not an Anchor)
3	Cable Lifeline
4	Cable Stop/Handle Assembly
5	Swaged Eye
6	Energy Absorber
7	Steel Swivel Snap Hook

Figure 1

## 2.1 American National Standards Institute (ANSI) and Occupational Safety and Health Administration (OSHA):

The SRD discussed in this manual meets the standards of ANSI Z359.14-2021, ANSI A10.32-2012, and Occupational Safety and Health Administration (OSHA) regulations 1926.502 and 1910.140. ANSI requires SRDs be classified according to the type of usage the user would be exposed to, and are tested either as Class 1 or Class 2. Dynamic performance means that the SRD is installed in a testing drop tower. A test weight is attached to the SRD and then dropped. Test results are recorded.

Parameters recorded are:

- Arrest Distance (AD)
- Average Arrest Force (AAF)
- Maximum Arrest Force (MAF)

The Arrest Distance is the total vertical distance required to arrest a fall. The Arrest Distance includes the deceleration distance and the activation distance. The Average Arrest Force is the average of the forces applied to the body and the anchorage by the fall protection system. The Maximum Arrest Force is the maximum amount of force that may be applied to the body and the anchorage by the fall protection system. In addition to the above tests conducted in ambient conditions, the units must be retested for average and peak forces under certain environmental conditions, where the units are cooled, then tested, heated, then tested, or saturated in water and tested again. Separate units may be used for each test. All test results are recorded.

This test data is then used to establish the basis for fall clearance guidelines published in the user instruction manual.

Class 1 and 2: Class 1 devices shall be used only on overhead anchorages and shall be subjected to a maximum free fall of 2 feet (0.6 m) or less. Class 2 devices are intended for applications where an overhead anchorage may not be available or feasible and be subjected to a free fall of no more than 6 feet (1.8 m) over an edge.

To be declared a Class 1 and Class 2 device, ANSI requires an SRD to have an overhead Arrest Distance of less than 42" (1.1 m), an Average Arrest Force of less than 1,350 lbs (6 kN) [1,575 lbs (7 kN) conditioned] and a Maximum Arresting Force of 1,800 lbs (8 kN), for both ambient and conditioned testing.

When dynamically tested in accordance with requirements of ANSI Z359.14-2021, FallTech Class 1 and Class 2 Self-Retracting Devices have an AAF of 1,350 lbs (6 kN) or less and an AD of less than 42" (1.1 m).

Please see Section 5 of this user instruction manual for how to calculate your Minimum Required Fall Clearance (MRFC).

Class 2 SRLs shall include labels illustrating a fall clearance table and a diagram of the axes shown on the table. These labels shall be affixed to the product. The FT-R+ Leading Edge includes these labels in the Energy Absorber.

Please see Section 5.2 of this user instruction manual for how to calculate your Minimum Required Fall Clearance (MRFC) using the affixed labels.

Classification information found on product labels is based on test results. Table 1B provides test performance results for the SRD discussed in this manual.

**NOTE:** Arrest distance is one of several parts of the Minimum Required Fall Clearance (MRFC). MRFC is discussed in detail in Section 5 .

OSHA requires an SRD limit the free fall to 2 feet (0.9 m) or less. If the maximum free fall distance must be exceeded, the employer must document, based on test data, that the maximum arresting force will not be exceeded, and the personal fall arrest system will function properly. The SRD discussed in this manual was successfully tested for horizontal use and falls over a steel edge without burrs, as found on steel shapes and metal sheeting, and may be used in situations where a fall may occur over similar edges, such as found on steel shapes or metal sheeting.

## 2.2 Canadian Standards Organization (CSA):

The FT-R+ SRL-LE described in this manual, when used per the instruction in this manual meets or exceeds CSA Z259.2.2-2017. CSA requires that all SRDs be classified according to their respective type, and are classified either as; Class SRL, Class SRL-R, Class SRL-LE, or Class SRL-LE-R. The FT-R+ SRL-LE Self Retracting Device in this manual is Class SRL-LE.

CSA Test Parameters used in this manual are:

- Arrest Distance (AD)
- Average Arrest Force (AAF)
- Maximum Arrest Force (MAF)

The Arrest Distance is the total vertical distance required to arrest a fall. The Arrest Distance includes the deceleration distance and the activation distance. The Average Arrest Force is the average of the forces applied to the body and the anchorage by the fall protection system. The Maximum Peak Arrest Force is the maximum amount of force that may be applied to the body and the anchorage by the fall protection system. In addition to the above tests conducted in ambient conditions, the units must be retested for average and peak forces under certain environmental conditions, where the units are cooled, then tested, and saturated in water and tested again. Separate units are used for each test. All test results are recorded.

## 3.0 Application

### 3.1 Purpose:

The FallTech FT-R+ Leading Edge SRL is designed to be used as a component in a Personal Fall Arrest System (PFAS), to provide a combination of worker mobility and fall protection as required for inspection work, general construction, maintenance work, oil production, confined space work, etc. The SRL-LE is intended for fall protection in Leading Edge applications where falls may occur over edges.

### 3.2 Personal Fall Arrest System:

A PFAS is an assembly of components and subsystems used to arrest a person during a fall event. A PFAS typically consists of an anchorage, a deceleration device such as a Shock Absorbing Lanyard (SAL), a Self-Retracting Device (SRD), or a Fall Arrestor Connecting Subsystem (FACSS), and a properly fitted Full Body Harness (FBH). Maximum permissible free fall in a typical PFAS is 6' (1.8 m). The SRD discussed in this manual may be used in non-overhead anchorage situations. Clearance calculators provided in this manual offer methods for calculating MRFC for non-overhead anchorage locations when the SRD is set back from 0' to 4' (1.2 m) and non-overhead anchorage locations that are set back 5' (1.5m) or greater, see Figure 2.

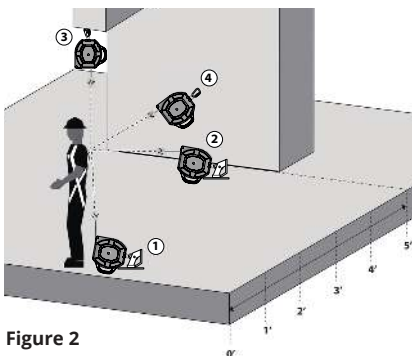

Figure 2

Figure 2 - Anchorage Locations

1	Anchorage of SRD at Foot Level with 0' Setback from Leading Edge
2	Anchorage of SRD at Foot Level with 5' Setback from Leading Edge
3	Overhead Anchorage of SRD Above Dorsal D-Ring
4	Anchorage of SRD Above Dorsal D-Ring with 5' Setback from Leading Edge

### 3.3 Horizontal Lifeline (HLL) and Rail Systems:

The SRD may be attached to rigid and flexible anchors provided that all HLL or rail system applications, installation, and uses are under the supervision of a Qualified Person.

### 3.4 Rescue:

Ensure a written rescue plan, method and system is in place and readily available for rapid response. Rescues may require specialized equipment or measures. Rescue operations are beyond the scope of this manual. See ANSI Z359.4 and Z359.2.

### 3.5 Application Limits:

The SRD discussed in this manual is designed for Leading Edge applications. However, take caution to avoid very sharp edges such as sheared metals, metals cut with an abrasive disk, or flame-cut metals. Also take caution around very abrasive surfaces and edges, such as concrete or stone, as these edges and surfaces may abrade the lifeline or the energy absorber during a fall event.

## 4.0 System Requirements

### 4.1 Capacity:

The SRD is designed for use by a single user with a combined weight of user, tools, clothing, etc., of:

- 130 – 310 lbs. (59 - 141 kg) to comply with ANSI and OSHA
- 130 - 420 lbs. (59 - 191 kg) to comply with CSA and OSHA

### 4.2 Compatibility of Connectors:

Connectors are considered to be compatible with connecting elements when they have been designed to work together in such a way that their sizes and shapes do not cause their gate mechanisms to inadvertently open regardless of how they become oriented. Contact FallTech if you have any questions about compatibility. Connectors must be compatible with the anchorage or other system components. Do not use equipment that is not compatible. Non-compatible connectors may unintentionally disengage. Connectors must be compatible in size, shape, and strength. Self-closing, self-locking connectors are required by ANSI and OSHA.

### 4.3 Compatibility of Components:

Equipment is designed for use with approved components and subsystems only. Substitutions or replacements made with non-approved components or subsystems may jeopardize compatibility of equipment and may affect the safety and reliability of the complete system.

### 4.4 Making Connections:

Only use self-locking connectors with this equipment. Only use connectors that are suitable to each application. Ensure all connections are compatible in size, shape, and strength. Do not use equipment that is not compatible, see Figure 3. Visually ensure all connectors are fully closed and locked. Connectors are designed to be used only as specified in each product's user's instructions.

### 4.5 Personal Fall Arrest System:

A PFAS is an assembly of components and subsystems used to arrest a person during a fall event. A PFAS is typically composed of an anchorage and a FBH, with an energy absorbing connecting device, i.e., an SAL, an SRD, or a Fall Arrester Connecting Subsystem (FACSS), connected to the dorsal D-ring of the FBH. PFAS components used in conjunction with this SRD should comply with ANSI Z359, CSA Z259 requirements, and applicable OSHA regulations.

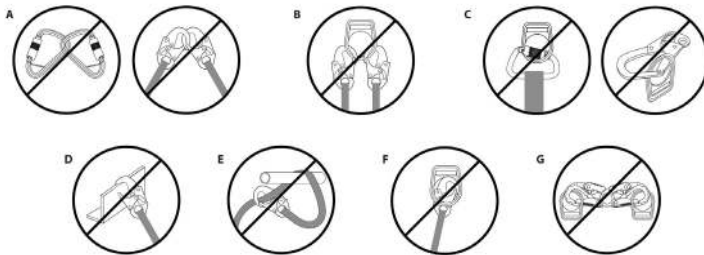

Figure 3

Figure 3 - Non-Compatible Connections	
<b>A</b>	Never connect two active components (snap hooks or carabiners) to each other.
<b>B</b>	Never connect two active components (snap hooks or carabiners) to a single D-ring at the same time.
<b>C</b>	Never connect in a way that would produce a condition of loading on the gate.

**Figure 3 - Non-Compatible Connections**

<b>D</b>	Never attach to a object in a manner whereby the gate (of the snap hook or carabiner) would be prevented from fully closing and locking. Always guard against false connections by visually inspecting for closure and lock.
<b>E</b>	Never attach explicitly to a constituent subcomponent (webbing, cable or rope) unless specifically provided for by the manufacturer's instructions for both subcomponents (snap hook or carabiner and webbing, cable or rope).
<b>F</b>	Never attach in a manner where an element of the connector (gate or release lever) may become caught on the anchor thereby producing additional risk of false engagement.
<b>G</b>	Never attach a spreader snap hook to two side/positioning D-rings in a manner whereby the D-rings will engage the gates; the gates on a spreader must always be facing away from the D-rings during work positioning.

#### 4.6 Average Arrest Force and Arrest Distance:

Table 1B provides test data on typical performance attributes of the three principal parameters, Arrest Distance, Average Arrest Force and Maximum Arrest Force, listed by model number and class. Testing is conducted under various environmental conditions; at ambient temperature, plus hot, cold, and in wet conditions. In manufacturer's tests, worst case performance attributes of the SRD, connected at foot-level (maximum of 5 feet below the dorsal D-ring) in a Leading Edge application with 5' (1.5m) of setback, or with 0' setback, are:

<b>130 to 310 lbs. (59 to 141 kg)</b>	<b>5' (1.5 m) Setback</b>	<b>0' Setback</b>
Longest Arrest Distance	74" (1.9 m)	81" (2.4 m)
Largest Average Arrest Force	707 lbs (3.1 kN)	1,041 lbs (4.6 kN)
Largest Maximum Arrest Force	1,222 lbs (5.4 kN)	1,557 lbs (6.9 kN)

<b>130 to 420 lbs. (59 to 191 kg)</b>	<b>5' (1.5 m) Setback</b>	<b>0' Setback</b>
Longest Arrest Distance	94" (2.4 m)	104" (2.6 m)
Largest Average Arrest Force	675 lbs (3.0 kN)	1,000 lbs (4.5 kN)
Largest Maximum Arrest Force	1,206 lbs (5.4 kN)	1,514 lbs (6.7 kN)

The Competent Person may find this data useful with planning anchorage location and calculating fall arrest loads and distances from the walking/working level to the nearest obstruction or lower level. See Section 5.

**NOTE:** Arrest distance is one part of the Minimum Required Fall Clearance (MRFC). The MRFC is determined by consideration of multiple factors in fall protection. Attachment below the level of the FBH D-ring will require additional fall clearance. MRFC is discussed in detail in Section 5.

#### 4.7 PFAS Anchorage Strength:

An anchorage selected for PFAS must have a strength able to sustain a static load applied in the direction permitted by the PFAS of at least:

- Two times the maximum arrest force permitted when certification exists, or
- 5,000 lbs. (22.2 kN) in the absence of certification.

Select an anchorage location carefully. Consider structural strength, obstructions in the fall path, and swing fall hazards. In certain situations, the qualified person can determine that a given structure is able to withstand the applied MAF of the PFAS with a safety factor of at least two, as required by OSHA.



**WARNING**

**Do not alter or intentionally misuse this equipment. Consult FallTech when using this equipment in combination with components or subsystems other than those described in this manual. All components or subsystems used with the SRD discussed in this manual must be in**

## compliance with ANSI Z359, CSA Z259, and/or OSHA.

**Do not use rebar hooks, large carabiners, or large snap hooks to connect to the FBH dorsal D-rings or to any small diameter non-compatible anchor point as this may cause a roll-out condition and/or unintentional disengagement.**

**Do not insert extra connectors between the SRD lifeline connector and the FBH dorsal D-ring, except an approved D-ring extender.**

**Use caution. Take action to avoid sharp and/or abrasive surfaces and edges when possible.**

### 5.0 Installation and Use

#### 5.1 Install the SRD

Examine the work area for possible hazards. Take caution to avoid overhead hazards such as cranes, poles, overhead power cables, and walking/working surface hazards such as power cables, welding leads, air and fluid hoses, including obstruction hazards such as vertical columns and stacks of materials on the lower level. Eliminate hazards where possible.

Ensure the anchorage provides the Minimum Required Fall Clearance (MRFC) in the fall path below the walking/working surface to prevent striking the lower level or an obstruction during a fall event. Take action to avoid swing falls, which occur when the anchorage is not directly above the point where the fall occurs.

Fall clearance and swing falls are subject to variable conditions. Anchor height, lateral movement, and setback distance all affect anchor location with regard to fall clearance and swing fall.

The SRD may be attached to an overhead anchor, i.e. above the user's FBH dorsal D-ring, or a non-overhead anchor, i.e., below the user's FBH dorsal D-ring. A non-overhead anchor may be as low as foot level, but no more than a maximum of 5' (1.5m) below the user's FBH dorsal D-ring. Non-overhead anchor locations result in greater contact between the lifeline and the edge and present greater abrasion risk hazards.

Use of a foot level anchorage should be as a last resort, when no other anchor option exists.

Performance testing has shown that a fall event over a leading edge will alter SRD performance characteristics and fall clearance requirements. When anchored below the FBH back D-ring fall events will result in greater fall clearances. Reduced setback distances will also increase clearance requirements. Non-overhead anchorage when the SRD is set back less than 5' (1.5 m) will result in the greatest MRFC and the least amount of worker mobility due to swing fall. Greater set back distances of 5' (1.5 m) or more will reduce the overall MRFC and allow for more lateral movement of the worker when attached to a non-overhead anchorage.

If job site geometry allows it, a setback distance of 5' (1.5 m) is recommended to take full advantage of the SRD performance. In addition, the Angle of Redirection of the lifeline, i.e., the angle of the lifeline as it passes over the edge, must be at 90 degrees or more, never less, see Section 5.3.

Do not attach the SRD in a manner that places the edge higher than the SRD.

#### 5.1.1 CSA Z259.2.2-17:

Deployment is equal to deployment factor times free-fall distance, h, see table below for deployment factor.

FT-R+ Device Length	TBD	30'	TBD
Deployment Factor for a 191 kg mass	TBD	1.0	TBD
Maximum Deployment Distance (Overhead Anchorage)	TBD	2.8 ft (0.9 m)	TBD
Maximum Deployment Distance (1.8 m (6 ft) Free Fall)	TBD	7.3 ft (2.2 m)	TBD
Average Deployment Force	TBD	876 lbs (3.9 kN)	TBD
Maximum Arrest Force	TBD	1,386 lbs (6.1 kN)	TBD

## 5.2 Calculating Minimum Required Fall Clearance

### 5.2.1 FT-R+ in Overhead, Non-Leading Edge Anchorage Application

The FT-R+ may be used as a standard SRD in an overhead condition, in which the SRD is installed anywhere in the allowable attachment area, which ranges from directly above the user to level with the FBH D-ring, as shown in Figure 4.

The overhead condition minimum required fall clearance (MRFC) is calculated using four metrics, measured from the walking-working surface: SRD Deceleration Distance, D-Ring Shift and Harness Stretch [1 ft (0.3m)], Safety Factor [1.5 ft (0.5m)], and Swing Fall.

Chart 1 below is calculated using the performance data of the SRD for workers weighing up to 420 pounds and includes all four metrics listed previously to determine the MRFC.

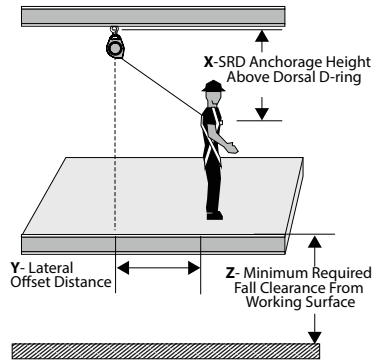



Figure 4

Using Chart 1 to Calculate Minimum Required Fall Clearance for the FT-R+	
4 foot (1.3 m) increments along the Y-Axis represent the Lateral Offset Distance the user is working away from being directly under the SRD	10 foot (3.1 m) increments up the X-Axis represent the SRD Anchorage Height above the user's Dorsal D-Ring
<p><b>Example:</b> If the user needs to work 8 feet (2.4 m) away from directly under the SRD, the SRD needs to be anchored at least 10 feet (3.1 m) above the user's Dorsal D-Ring. Minimum required fall clearance is 9.0 feet (2.7 m) at maximum allowable swing fall.</p>	
<p><b>Example:</b> If the only suitable Anchorage for the SRD is at D-Ring height [0.0 feet (0.0 m)] above the user's Dorsal D-Ring, the maximum allowable work zone is 4 feet (1.3 m) away from the SRD. Minimum required fall clearance is 10.0 feet (3.1m) at maximum allowable swing fall.</p>	
<p><b>Key to Work Zone Areas:</b></p> <p><input type="checkbox"/> = Allowable Use Area      <input checked="" type="checkbox"/> = Not Allowed Use Area</p>	
<p> <b>WORKING IN THIS AREA</b>      <input checked="" type="checkbox"/> <b>MAY RESULT IN SERIOUS INJURY OR DEATH</b></p>	

**Chart 1 - MRFC Overhead Anchorage for 130 to 420 lbs. (59 to 191 kg) Users**

		Lateral Offset Distance (Y) <span style="float: right;">→</span>						
		0 ft (0 m)	4 ft (1.3 m)	8 ft (2.5 m)	12 ft (3.7 m)	16 ft (4.9 m)	20 ft (6.1 m)	24 ft (7.4 m)
<b>SRD Anchorage Height Above Dorsal D-Ring (X)</b>	60 ft (18.3 m)	6.0 (1.9)	6.5 (1.9)	7.0 (2.0)	7.5 (2.2)	8.5 (2.5)	9.5 (2.9)	11.0 (3.3)
	50 ft (15.3 m)	6.0 (1.9)	6.5 (1.9)	7.0 (2.1)	7.5 (2.3)	8.5 (2.6)	10.0 (3.1)	11.5 (3.5)
	40 ft (12.2 m)	6.0 (1.9)	6.5 (1.9)	7.0 (2.1)	8.0 (2.4)	9.5 (2.8)	11.0 (3.3)	13.0 (3.9)
	30 ft (9.2 m)	6.0 (1.9)	6.5 (2.0)	7.5 (2.2)	8.5 (2.6)	10.0 (3.1)	12.5 (3.7)	14.5 (4.4)
	20 ft (6.1 m)	6.0 (1.9)	6.5 (2.0)	8.0 (2.3)	9.5 (2.9)	12.0 (3.6)	14.5 (4.4)	17.5 (5.3)
	10 ft (3.1 m)	6.0 (1.9)	7.0 (2.1)	9.0 (2.7)	12.0 (3.6)	15.0 (4.6)	18.5 (5.6)	22.0 (6.8)
	0 ft (0 m)	6.0 (1.9)	10.0 (3.1)	14.0 (4.3)	18.0 (5.5)	22.0 (6.8)	26.0 (8.0)	30.0 (9.2)



This product is AXIS™ enabled.

- Intuitive and precise fall clearance calculator
- Offers dynamic 3D representation for accurate assessments
- Calculates fall clearance specific to this product

Scan QR code to try AXIS for streamlined safety compliance.

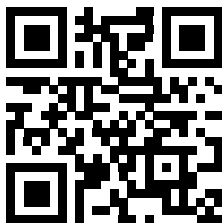

### 5.2.2 FT-R+ Non-Overhead Anchorage

The leading edge/below D-ring condition minimum required fall clearance (MRFC) is calculated using five metrics, measured from the walking- working surface: SRD Deceleration Distance, D-Ring Shift and Harness Stretch [1 ft (0.3m)], Safety Factor [1.5 ft (0.5m)], Dorsal D-ring Height [5 ft (1.5m)], and Swing Fall. Dorsal D-ring height is added to account for the below D-ring tie-off compared to the overhead condition.

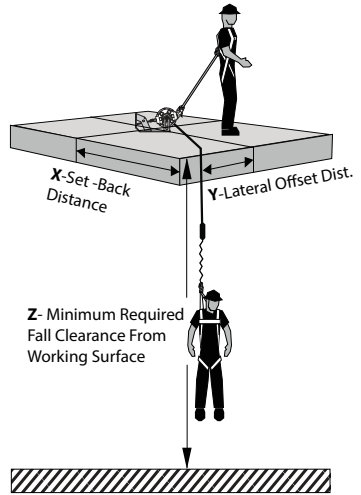

Chart 2 below is calculated using the performance data of the 30' SRD for workers weighing up to 310 pounds and includes all five metrics listed previously to determine the MRFC.

Chart 3 below is calculated using the performance data of the 30' SRD for workers weighing up to 420 pounds and includes all five metrics listed previously to determine the MRFC.

Chart 2 - 30' FT-R+ MRFC Non-Overhead Anchorage for 130 to 310 lbs. (59 to 141 kg) Users											
		Lateral Offset Distance (Y) →									
		0 ft (0 m)	2 ft (0.7 m)	4 ft (1.3 m)	6 ft (1.9 m)	8 ft (2.5 m)	10 ft (3.1 m)	12 ft (3.7 m)	14 ft (4.3 m)	16 ft (4.9 m)	18 ft (5.5 m)
SRD Setback Distance from Edge (X)	0 ft (0 m)	14.5 (4.4)	16.5 (5.0)	18.5 (5.6)	20.5 (6.2)	22.5 (6.8)	24.5 (7.5)	26.5 (8.1)	28.5 (8.7)	30.5 (9.2)	32.5 (9.9)
	5 ft (1.6 m)	14.5 (4.4)	15.0 (4.6)	16.0 (4.9)	17.5 (5.3)	19.0 (5.8)	20.5 (6.2)	22.5 (6.8)	24.5 (7.5)	26.0 (7.9)	28.0 (8.5)
	10 ft (3.1 m)	14.5 (4.4)	14.5 (4.4)	15.0 (4.6)	16.0 (4.9)	17.5 (5.3)	18.5 (5.6)	20.0 (6.1)	21.5 (6.5)	23.5 (7.2)	25.0 (7.6)
	15 ft (4.6 m)	14.5 (4.4)	14.5 (4.4)	15.0 (4.6)	15.5 (4.7)	16.5 (5.0)	17.5 (5.3)	18.5 (5.6)	20.0 (6.1)	21.5 (6.6)	23.0 (7.0)
	20 ft (6.1 m)	14.5 (4.4)	14.5 (4.4)	15.0 (4.6)	15.5 (4.7)	16.0 (4.9)	17.0 (5.2)	18.0 (5.5)	19.0 (5.8)	20.0 (6.1)	21.5 (6.5)
	25 ft (7.7 m)	14.5 (4.4)	14.5 (4.4)	15.0 (4.6)	15.0 (4.6)	15.5 (4.7)	16.5 (5.0)	17.0 (5.2)	18.0 (5.5)	19.0 (5.8)	20.5 (6.2)
	30 ft (9.2 m)	14.5 (4.4)	14.5 (4.4)	14.5 (4.4)	15.0 (4.6)	15.5 (4.7)	16.0 (4.9)	17.0 (5.2)	17.5 (5.3)	18.5 (5.6)	19.5 (5.9)

#### Using Chart 2 to Calculate Minimum Required Fall Clearance for the FT-R+

4 foot (1.3 m) increments along the Y-Axis represent the Lateral Offset Distance the user is working away from being directly under the SRD

5 foot (1.5 m) increments up the X-Axis represent the SRD Setback Distance from Edge

**Example:**

If the user needs to work 10 feet (3.1 m) away from the SRD along the edge, the SRD needs to be anchored back at least 15 feet (4.6 m) from the edge. Minimum required fall clearance is 17.5 feet (5.3 m) at maximum allowable swing fall.

**Example:**

If the only suitable Anchorage for the SRD is at the edge [0 feet (0.0 m)], the maximum allowable work zone is 4 feet (1.3 m) away from the SRD. Minimum required fall clearance is 18.5 feet (5.6 m) at maximum allowable swing fall.

**Key to Work Zone Areas:**



= Allowable Use Area



= Not Allowed Use Area



**WORKING IN THIS AREA**



**MAY RESULT IN SERIOUS INJURY OR DEATH**

**Chart 3 - 30' FT-R+ MRFC Non-Overhead Anchorage for 130 to 420 lbs. (59 to 191 kg) Users**

		Lateral Offset Distance (Y) <span style="float: right;">→</span>									
		0 ft (0 m)	2 ft (0.7 m)	4 ft (1.3 m)	6 ft (1.9 m)	8 ft (2.5 m)	10 ft (3.1 m)	12 ft (3.7 m)	14 ft (4.3 m)	16 ft (4.9 m)	18 ft (5.5 m)
SRD Setback Distance from Edge (X)	0 ft (0 m)	16.5 (5.1)	18.5 (5.7)	20.5 (6.2)	22.5 (6.8)	24.5 (7.5)	26.5 (8.1)	28.5 (8.7)	30.5 (9.2)	32.5 (9.9)	34.5 (10.6)
	5 ft (1.6 m)	16.5 (5.1)	17.0 (5.2)	18.0 (5.5)	19.5 (5.9)	21.0 (6.4)	22.5 (6.8)	24.5 (7.5)	26.5 (8.1)	28.0 (8.5)	30.0 (9.1)
	10 ft (3.1 m)	16.5 (5.1)	16.5 (5.1)	17.0 (5.2)	18.0 (5.5)	19.5 (5.9)	20.5 (6.2)	22.0 (6.8)	23.5 (7.2)	25.5 (7.8)	27.0 (8.2)
	15 ft (4.6 m)	16.5 (5.1)	16.5 (5.1)	17.0 (5.2)	17.5 (5.3)	18.5 (5.6)	19.5 (5.9)	20.5 (6.2)	22.0 (6.7)	23.5 (7.2)	25.0 (7.6)
	20 ft (6.1 m)	16.5 (5.1)	16.5 (5.1)	17.0 (5.2)	17.5 (5.3)	18.0 (5.5)	19.0 (5.8)	20.0 (6.1)	21.0 (6.3)	22.0 (6.8)	23.5 (7.2)
	25 ft (7.7 m)	16.5 (5.1)	16.5 (5.1)	17.0 (5.2)	17.0 (5.2)	17.5 (5.3)	18.5 (5.6)	19.0 (5.8)	20.0 (6.1)	21.0 (6.3)	22.5 (6.8)
	30 ft (9.2 m)	16.5 (5.1)	16.5 (5.1)	16.5 (5.1)	17.0 (5.2)	17.5 (5.3)	18.0 (5.5)	19.0 (5.8)	19.5 (5.9)	20.5 (6.2)	21.5 (6.5)



This product is AXIS™ enabled.

- Intuitive and precise fall clearance calculator
- Offers dynamic 3D representation for accurate assessments
- Calculates fall clearance specific to this product

Scan QR code to try AXIS for streamlined safety compliance.

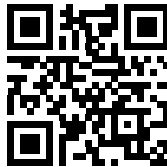

**⚠ WARNING**

An expanded work zone combined with an SRD attached at or near foot level will have a high risk of serious injury or death.

### 5.3 Angle of Redirection:

The angle of redirection is the angle of the lifeline over an edge during a fall event. Install the SRD so that the angle of the two parts of the lifeline are at least 90°, or more, but never less, as shown in Figure 5. The lifeline must never rise up to the edge as it may bend the lifeline in too small a radius and/or severely abrade, or otherwise compromise, the lifeline.

Do not work with the leading edge above the anchorage.

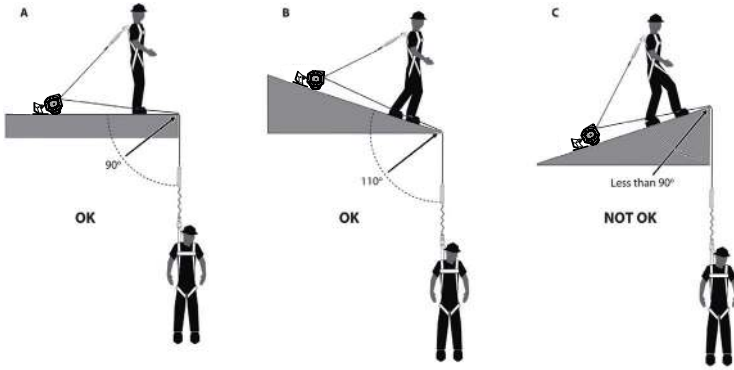

Figure 5 - Leading Edge Angle of Lifeline Redirect

### 5.4 Edge Conditions

Leading Edge conditions vary, and may be composed of steel, I-beams with purlins, steel deck, metal roofing, or poured concrete or cinder block as shown in Figure 6.

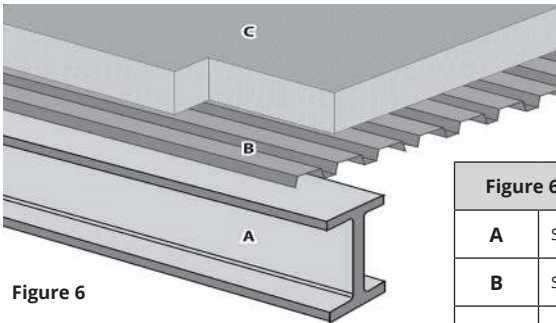

Figure 6

Figure 6 - Typical Extreme Sharp Edges

<b>A</b>	Structural Steel I-Beams and Purlins
<b>B</b>	Steel Deck and Metal Roofing
<b>C</b>	Poured Concrete and Concrete Block

**Examples not intended to depict the full extent of all hazardous sharp edges found on job sites for the user to identify and avoid.**

### 5.5 Incorrect Use:

Additional factors to avoid, shown in Figure 7:

Do not allow the lifeline to drape over an edge during normal work as this may abrade, damage, or otherwise compromise the lifeline.

Do not attach the anchor on one side of an opening and work on the other side, as this creates multiple possible leading edges and potential swing fall hazards.

### 5.6 Operation of the SRD:

Before each use, inspect the SRD, see Section 7 for inspection instructions.

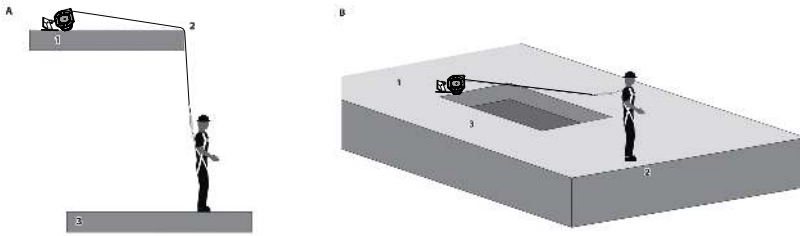

Figure 7 - Incorrect Use of Leading Edge SRD	
<b>A</b>	Do Not subject cable lifeline to Leading or Sharp Edge during normal use
<b>B</b>	Do Not anchor SRD on opposite side of existing hole or floor opening from work location

1. Anchorage 2. Leading Edge 3. Walking/Working Surface

### 5.6.1 Locking Mechanism:

The SRD utilizes an acceleration based locking mechanism. The locking function requires a certain payout rate during a fall event to function correctly. Certain situations, confined or cramped spaces, shifting footing such as sand, gravel, grain, or a sloped surface may not allow the lifeline to reach sufficient speed to activate the lock mechanism. A clear path is required to assure positive locking of the SRD. Ensure the lock is functioning properly. Pull the lifeline out a short distance and give it a sharp tug. The lifeline must lock. If it fails to lock, remove it from service immediately. Ensure the work zone remains within stated parameters. Beware of Leading Edge hazards.

DO NOT attach an additional shock absorbing lanyard or similar device between the SRD housing and the anchorage.

### 5.6.2 Fall Arrest Impact Indicator:

The primary fall arrest impact indicator is the load-indicating Energy Absorber. The Energy Absorber will display a red and white band if it has been subjected to fall arrest, or equal, forces, as shown in Figure 8, Image B. If the Energy Absorber shows any sign of damage, torn or ripped cover, frayed thread, burns or trauma of any kind, remove the unit from service.

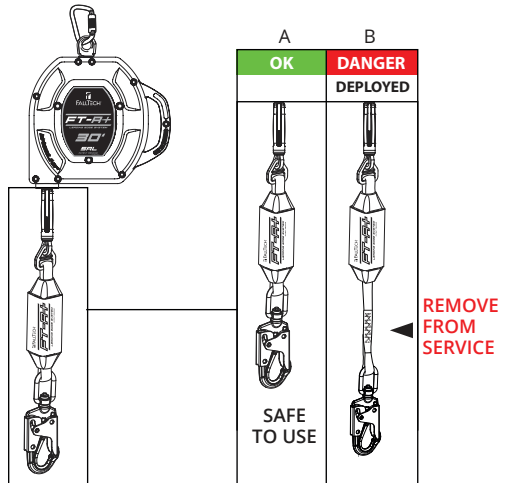

Figure 8 - Inspecting SRD Load-Indicating Energy Absorber

### 5.6.3 Inspect the Cable:

The SRD lifeline is steel cable, and subject to certain hazards. Inspect the lifeline before each use for the conditions as described in Section 7.

### 5.7 Using the SRD:

Do not use the SRD if inspection shows damage or any malfunction. Don the FBH in accordance with the FBH manufacturer's instructions. Follow the instructions contained in this manual and on the labels. Failure to follow instructions may result in serious injury or death. Connect the leg end carabiner to the dorsal D-ring on the FBH. Ensure the carabiner closes and locks. Attach the housing carabiner to the chosen anchorage and ensure the carabiner closes and locks. Ensure all connections are compatible. Normal operation will allow the working length of the lifeline to extend and retract as the worker moves about. A certain amount of tension must remain on the cable at all times to ensure proper operation of the internal brake. Do not allow the lifeline to become slack. If the lifeline becomes slack, remove the SRD from service for inspection. See Section 7.

Avoid sudden or quick movements during the normal work operation, as this may cause the SRD brake to engage and possibly cause loss of balance and injury or death.

If a fall occurs, the brake will engage and lock the lifeline. The EA will deploy to arrest the fall and limit arrest forces on the user.

- DO NOT extend the lifeline past the operational limit.
- DO NOT allow one SRD lifeline to become tangled or twisted with another SRD lifeline during use.
- DO NOT allow any lifeline to pass under arms or between legs during use.
- DO NOT clamp, knot, or prevent the lifeline from retracting or being taut.
- DO NOT lengthen the SRD by connecting a lifeline or similar component.
- DO NOT allow the lifeline to remain outside the housing when not in use.
- DO NOT allow the lifeline to freewheel back into the housing. Use a tag line to maintain tension and rewind the lifeline during periods of inactivity. Use the tag line to retrieve the leg end connector for the next use.
- DO NOT leave the tag line connected to the leg end connector when using the SRD for fall protection.

### 5.8 After A Fall:

A fall event over an edge may require special rescue equipment and measures. Ensure a written rescue plan, method and system is in place and readily available to all users for rapid response. Ensure all users are trained in rescue procedures. If a fall event occurs, remove it from service, and store it separately. Remove from service any unit that has been subjected to fall arrest forces or that exhibits damage consistent with such forces. For questions, contact FallTech.

## 6.0 Maintenance, Service, and Storage

### 6.1 Maintenance:

Ensure the SRD is kept free of excess paint, grease, dirt or other contaminants as this may cause to cable or retracting mechanism to malfunction. Ensure no debris enters the housing through the cable access port. Clean the exterior of the unit as required with a detergent/water solution. Avoid water other corrosion causing elements to enter the housing. After cleaning, pull the lifeline all the way out, allow the unit to air dry, then retract the lifeline into the unit. Do not allow the lifeline to freewheel back into the housing. Clean labels as required.

- DO NOT use heat to dry.
- DO NOT attempt to disassemble the SRD.

### 6.2 Service:

The FT-R+ SRLs discussed in this manual feature SpeedLine™ field replaceable lifeline technology, which when appropriate, allows the end user's Competent Person to replace the lifeline of the FT-R+ SRL in the field. Units involved in a fall arrest or displaying a deployed impact indicator shall be permanently removed from service and shall not be repaired or serviced.

The Competent Person shall inspect the FT-R+ SRL per Section 7 of this user manual before SpeedLine replacement. This pre-replacement inspection shall confirm the only inspection failures are present on the replaceable section of lifeline of the FT-R+ SRL. If there are other inspection failures, tag the unit as "UNUSABLE", store separately, and contact FallTech at 1-800-719-4619 to receive a Return Authorization number or to locate the nearest FallTech Service Center. Any repair besides SpeedLine

replacement or additional service shall be completed by an authorized FallTech Service Center or entities authorized in writing by FallTech. Do not attempt to disassemble or lubricate the SRL. Only use FallTech replacement lifeline assemblies. End user lifeline replacement is not considered a repair or full service as it pertains to warranty claims. See Table 1D in Appendix A for list of replacement lifeline part numbers. Figure 9 below shows the tools in part number 5048, which includes the full tool set needed to replace the FT-R+ SpeedLine lifeline.

**WARNING:** SpeedLine replacement procedures described below may be hazardous. Please ensure proper personal protective equipment usage as required to prevent injury or death.

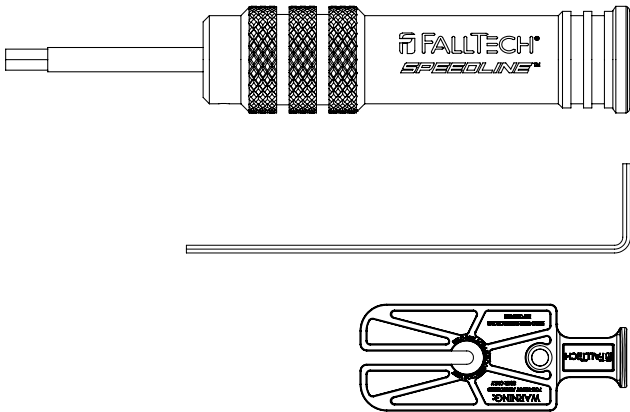
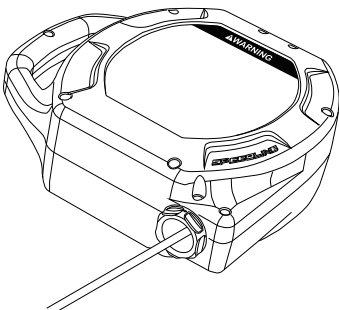

**Figure 9 - FT-R+ SpeedLine Tools**

<b>1</b>	5mm Security Hex Driver
<b>2</b>	0.05" Hex L-Key
<b>3</b>	SpeedLine Spacer

### FT-R+ SRL SpeedLine Lifeline Replacement Instructions

**Step 1:** Secure the unit to the work bench in the orientation shown. Secure the lifeline partially paid out from the device.



**Step 2:** Using the 5mm security hex driver, remove the housing screw adjacent to the SRL orifice. Retain screw for later use.

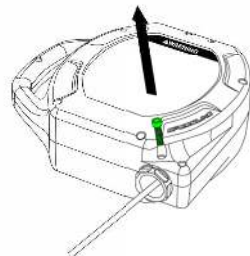

## FT-R+ SRL SpeedLine Lifeline Replacement Instructions (continued)

**Step 3:** With the housing screw removed, the orifice is now free and should be unscrewed 90 degrees counter clockwise and slid down lifeline.

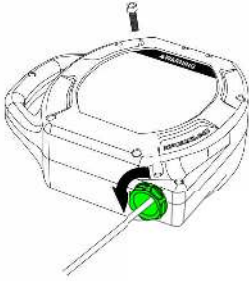

**Step 4:** Pay out the full SRL lifeline until the LineLoc connector is exposed as shown below.

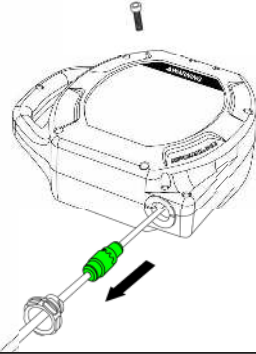

**Step 5:** Place the SpeedLine Spacer tool around the cable to prevent the LineLoc connector from being retracted into the housing.

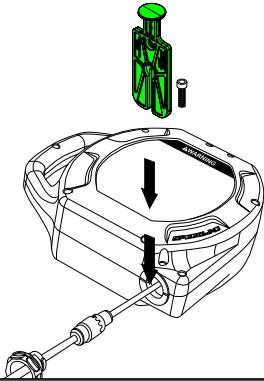

**Step 6:** Allow the device to retract so that the LineLoc connector is resting against the SpeedLine Spacer.

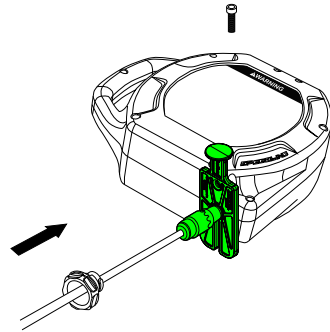

**Step 7:** Using the 0.05" hex L-key, remove the locking screw from the LineLoc connector and discard. DO NOT REUSE the locking screw.

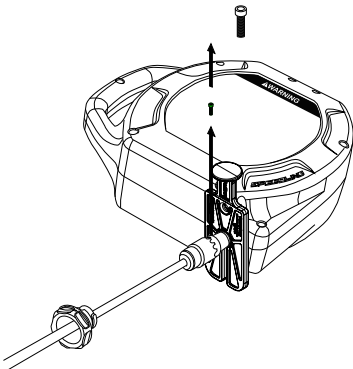

**Step 8:** Unscrew the lifeline side of the LineLoc connector and slide down the lifeline. NOTE: the locking pin may fall out during this step.

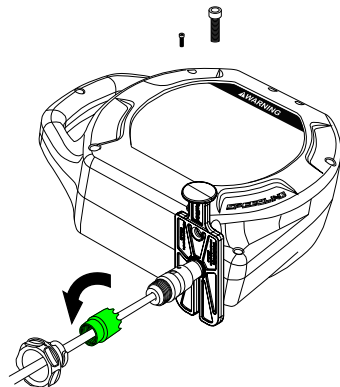

## FT-R+ SRL SpeedLine Lifeline Replacement Instructions (continued)

**Step 9:** Remove the locking pin from the LineLoc body and retain for later use.

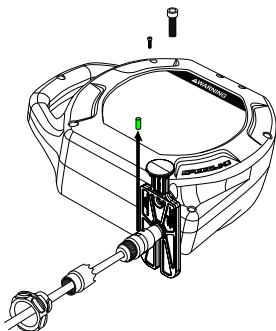

**Step 10:** Separate the lifeline side of the LineLoc connector and the lifeline subassembly from the housing side of the LineLoc connector.

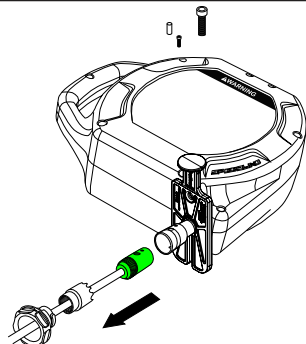

**Step 11:** Pull the terminated end of the lifeline cable out from the inside core of the LineLoc connector.

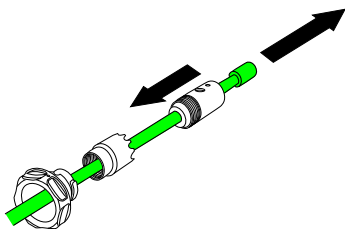

**Step 12:** Remove the threaded core of the LineLoc connector from the damaged cable. Retain for later use.

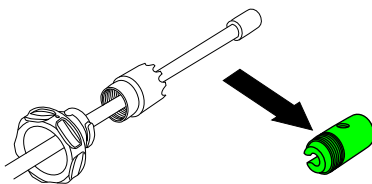

**Step 13:** Remove the damaged cable lifeline from the assembly. Keep the lifeline side of the LineLoc connector and the orifice for later use.

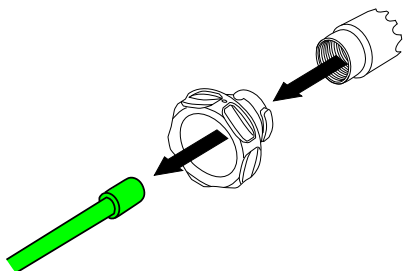

**Step 14:** Insert new cable lifeline through the orifice and then the lifeline side of the LineLoc connector in the orientations shown below.

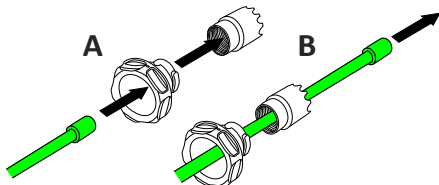

## FT-R+ SRL SpeedLine Lifeline Replacement Instructions (continued)

**Step 15:** Place the slot of the LineLoc's threaded core around the new cable with the threaded portion oriented as shown.

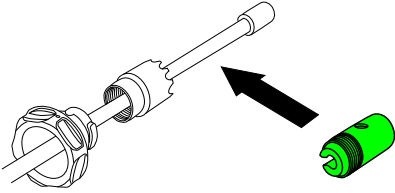

**Step 16:** Slide the threaded core of the LineLoc connector over the end termination of the cable.

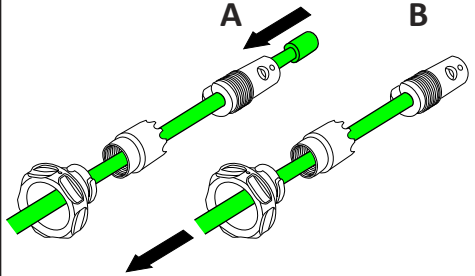

**Step 17:** Insert the LineLoc's threaded core with the cable termination captured into the housing side of the LineLoc connector.

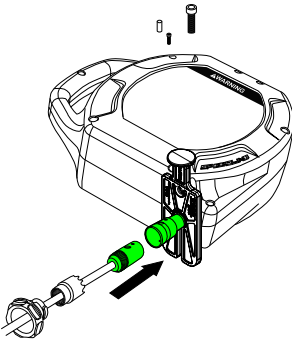

**Step 18:** Insert the locking pin through the housing side of the LineLoc connector and threaded core and hold in place for next step.

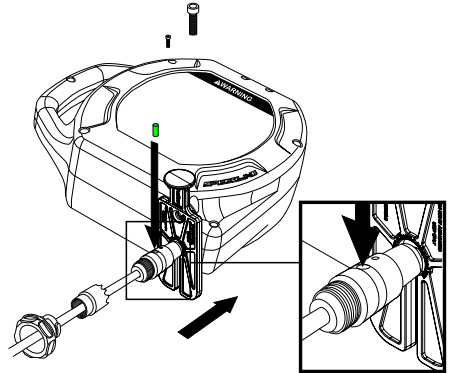

**Step 19:** While holding the locking pin in place, screw the lifeline side of the LineLoc connector onto the threaded core. The locking pin should now be contained within the assembly.

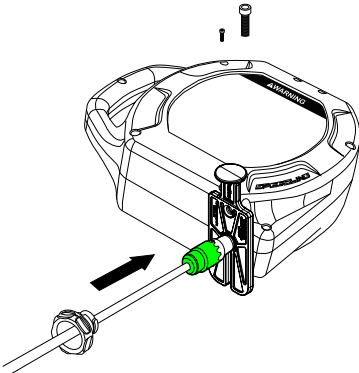

**Step 20:** Visually confirm the LineLoc connector notch is aligned with the locking screw opening as shown in the zoomed in image below.

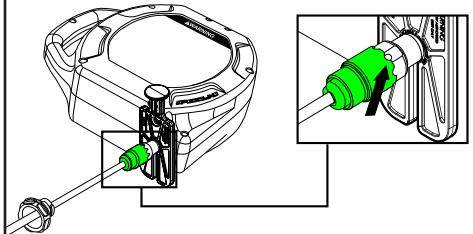

## FT-R+ SRL SpeedLine Lifeline Replacement Instructions (continued)

**Step 21:** Using the 0.05" hex L-key, secure the provided NEW locking screw in the LineLoc connector. DO NOT REUSE the old locking screw.

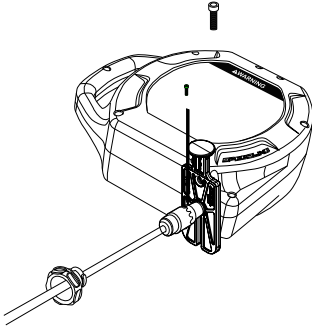

**Step 22:** Visually confirm that the locking screw is nested into the lifeline side of the LineLoc connector as shown below. The red band shall NOT be visible if assembled correctly.

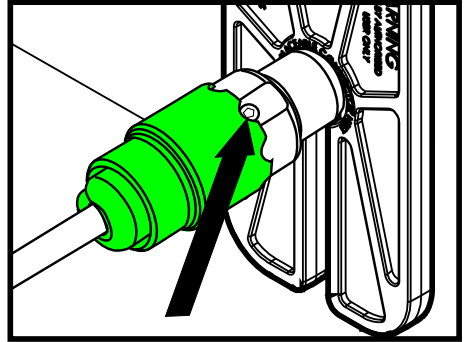

**Step 23:** Extract the lifeline a few inches to remove the SpeedLine Spacer tool, then secure the lifeline so it cannot retract into the SRL housing.

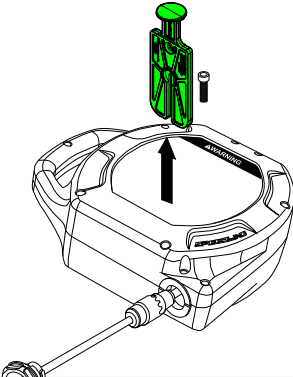

**Step 24:** Align and screw the orifice back into the SRL housing. NOTE: If the orifice was forgotten or oriented incorrectly, replace the SpeedLine Spacer and return to Step 6.

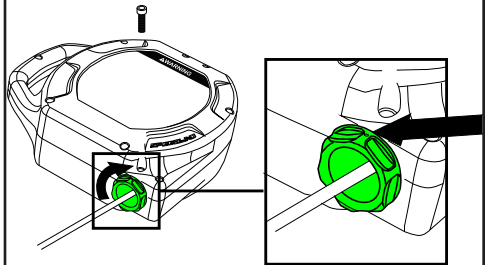

**Step 25:** Using the 5mm security hex driver, secure the two housing screws adjacent to the SRL orifice. The screws will secure the orifice in position.

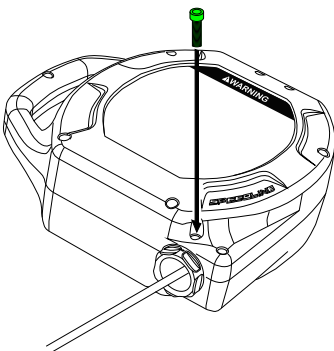

**Step 26:** Slowly and safely retract the lifeline back into the SRL housing. Do not allow freewheel retraction. Competent Person inspection required before returning to service.

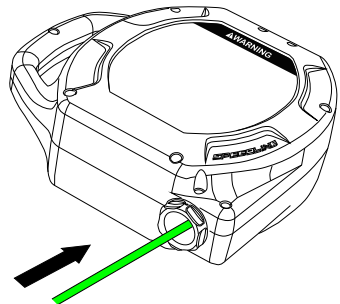

### 6.3 Storage:

Hang the SRD in a cool, dry, clean environment out of direct sunlight. Position the SRD so excess water can drain out. Avoid exposure to chemical or caustic vapors. Thoroughly inspect the SRD after any period of extended storage.

## 7.0 Inspection

### 7.1 Pre-Use User Inspection:

Perform an inspection before each use in accordance with the recommendations in Table 6 below.

Table 6 - Guidelines for Cable SRD Inspection		
Inspection	Pass	Fail
The cable lifeline should extract and retract completely and without faltering and should remain taut under tension without sagging.		
Extract the cable lifeline several inches and apply a firm pull to confirm the SRD locks. The locking should be certain and without skidding. Repeat this lockup at additional places along the lifeline length to confirm the SRD is operating correctly.		
Examine the load indicator on the Energy Absorber to be certain that it has not been loaded, impacted or activated. (see Figure 8 if needed)		
Inspect the entire length of the constituent line up. Review the cable lifeline closely for broken strand wires, welding spatter burns, welding slag, bird caging, kinks and bent strands. Also examine for rust, dirt, paint, grease or oil. Check for damage caused by chemical corrosion or excessive heat as evident with discoloration. See Figure 10 for examples. If any of these conditions exist, remove the SRD from service.		
Check for any missing or noticeably loose screws or nuts and any deformed or damaged components. Do not use tools to check screws as the screws may be unintentionally loosened or over-torqued.		
Examine the external housing for cracks, breaks or warping.		
Check the external Connector Eye and the Anchorage Carabiner for damage and deformation. The Anchorage Carabiner Gate should open and snap shut easily and smoothly.		
Examine the overall SRD unit for any indications of deterioration or damage.		
All labels must be intact and totally legible (see Section 8).		

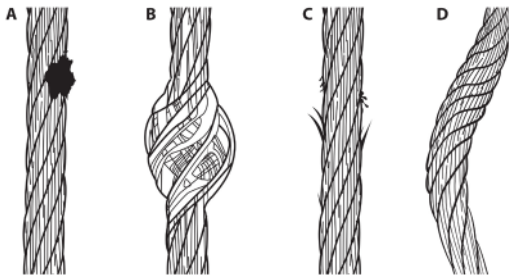

Figure 10: Inspection of Cable

Extract all of the cable and check the entire working length for damage caused by chemical corrosion or excessive heat as evident by discoloration (A), bird caging (B), broken wire strands (C), kinks and bent strands (D), see Figure 10. The cable should retract completely without faltering and should remain taut under tension without sagging.

### 7.2 Inspection Frequency:

Inspection by a competent person at regular intervals is required. The competent person will use the information in Table 7: SRD Inspection Recommendations, to determine the inspection frequency. Use Table 7 to determine the inspection frequency. Inspection by a factory authorized inspection entity at regular intervals is also required.

Table 7 - SRD Inspection Frequency Recommendations			
Type of Use	Application Examples	Conditions of Use	Inspection Frequency Competent Person
<b>Infrequent to Light Use</b>	Rescue and Confined Space, Factory Maintenance	Good Storage Conditions, Indoor or Infrequent Outdoor use, Room Temperature, Clean Environments	Annually
<b>Moderate to Heavy Use</b>	Transportation, Residential Construction, Utilities, Warehouse	Fair Storage Conditions, Indoor and extended outdoor use, All temperatures, Clean or dusty environments	Semi-annually to Annually
<b>Severe to Continuous Use</b>	Commercial Construction, Oil and Gas, Mining	Harsh Storage Conditions, Prolonged or Continuous outdoor Use, all temperatures, Dirty environments	Quarterly to Semi-annually

### 7.3 Inspection Checklist:

Use Table 6: Guidelines for Cable SRD Inspection to inspect the SRD. See Figure 14 for examples of cable damage.

### 7.4 Inspection Results:

If an inspection reveals defects in or damage to the equipment, inadequate maintenance or activated fall indicators, remove the equipment from service.

### 7.5 Inspection Document:

Record inspection results on the Inspection Record provided below or on a similar document.



# 8.0 Labels

Product labels must be present and legible.

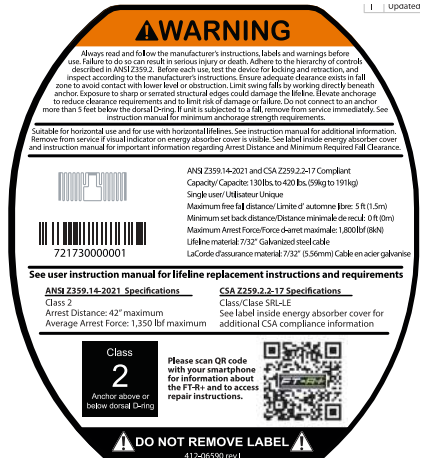

**Overhead Anchorage**      **User Weight 110-420 lb**  
**Clearance Chart - Read Instruction Manual for Complete Details**

SID Anchorage Height Above Dropped Swing (ft)	Lateral Offset Distance, ft (Y)											
	0	2	4	6	8	10	12	14	16	18	20	22
10 Feet	6.0	6.5	7.0	7.5	8.0	8.5	9.0	10.0	11.0	12.0	13.5	14.5
15 Feet	6.0	6.5	7.0	7.5	8.0	8.5	9.0	10.0	11.0	12.0	13.5	14.5
20 Feet	6.0	6.5	7.0	7.5	8.0	8.5	9.0	10.0	11.0	12.0	13.5	14.5
25 Feet	6.0	6.5	7.0	7.5	8.0	8.5	9.0	10.0	11.0	12.0	13.5	14.5
30 Feet	6.0	6.5	7.0	7.5	8.0	8.5	9.0	10.0	11.0	12.0	13.5	14.5

Minimum Required Fall Clearance, ft (Z) - Includes 1.5 foot Safety Margin  
See diagram for illustration of axes X, Y and Z.

XXX - Allowable Work Area

DO NOT REMOVE LABEL

XXX - Not Allowed Work Area Unless swing fall path is free of obstruction. A WARNING WORKING IN THIS AREA MAY RESULT IN SERIOUS INJURY OR DEATH.

**WARNING / AVERTISSEMENT**  
Leading Edge Device: Follow all manufacturer's instructions indicated at time of shipping. This device shall be removed from service when the visual lead indicator is deployed.  
Dispositif coupe pour le bord coquants: Suivre toutes les instructions du fabricant fournies avec le dispositif lors de sa livraison. AVERTISSEMENT: Ce dispositif doit être retiré du service lorsque l'indicateur de chute est activé.

**FALLTECH**  
**FT-R+**  
LEADING EDGE SYSTEM

Item # 412-06625 Rev A

Style#: 721730LER  
Date of Manufacture/Date de Fabrication: JAN 2005  
Serial Number/Numero de Serie: See Back of Housing Label

Working Length/Longueur de Treuil: 30 FT / 9.1 m  
Clearance required when falling over an edge/Dépassement requis en cas de chute sur un bord:  
14.5 ft (4.4m) for a 310 lb (141kg) user  
16.5 ft (5.0m) for a 420 lb (191kg) user

Additional clearance is required for swing fall.  
Un dépassement supplémentaire est requis pour la chute oscillante.

Deployment Factor for a 191kg Mass:  
Facteur de Déploiement pour une Masse de 191 kg: 1.0

Maximum Deployment Distance (Overhead Anchorage)  
Distance de Déploiement Maximale (Ancrege Aérien): 2.8ft (0.9m)

Maximum Deployment Distance 1.8 m (6 ft) Free Fall:  
Distance de Déploiement Maximale 1.8 m (5 pieds) en chute libre: 7.3ft (2.2m)

Average Deployment Force:  
Force de Déploiement Moyenne: 370 lbs (168kg)

MARK OR PUNCH ON DATE GRID:

A) INITIAL IN-SERVICE DATE  
B) DATE OF PASSED INSPECTION  
MARQUER CUPON/POINTEUR SUR LA GRILLE DES DATES:

A) DATE DE MISE EN SERVICE INITIALE  
B) DATE D'INSPECTION RÉUSSIE  
IF DUTY FALLS INSPECTION, REMOVE FROM SERVICE  
SI LIMITE DE CHUTE INSPECTION RÉUSSIE, RETIRER DU SERVICE

Initials: \_\_\_\_\_  
Date: \_\_\_\_\_

**Non-Overhead Anchorage**      **User Weight 110 - 310lb**  
**Clearance Chart - Read Instruction Manual for Complete Details**

Set-Back Distance, ft (X)	Lateral Offset Distance, ft (Y)											
	0	2	4	6	8	10	12	14	16	18	20	22
10 Feet	14.5	16.5	18.5	20.5	22.5	24.5	26.5	28.5	30.5	32.5	34.5	36.5
15 Feet	14.5	16.5	18.5	20.5	22.5	24.5	26.5	28.5	30.5	32.5	34.5	36.5
20 Feet	14.5	16.5	18.5	20.5	22.5	24.5	26.5	28.5	30.5	32.5	34.5	36.5
25 Feet	14.5	16.5	18.5	20.5	22.5	24.5	26.5	28.5	30.5	32.5	34.5	36.5
30 Feet	14.5	16.5	18.5	20.5	22.5	24.5	26.5	28.5	30.5	32.5	34.5	36.5

Minimum Required Fall Clearance, ft (Z) - Includes 1.5 foot Safety Margin  
See diagram for illustration of axes X, Y and Z.

XXX - Allowable Work Area

DO NOT REMOVE LABEL

XXX - Not Allowed Work Area Unless swing fall path is free of obstruction. A WARNING WORKING IN THIS AREA MAY RESULT IN SERIOUS INJURY OR DEATH.

**FALLTECH**  
**FT-R+**  
LEADING EDGE SYSTEM

Item # 412-06624 Rev A

**Non-Overhead Anchorage**      **User Weight 310-420 lb**  
**Clearance Chart - Read Instruction Manual for Complete Details**

Set-Back Distance, ft (X)	Lateral Offset Distance, ft (Y)											
	0	2	4	6	8	10	12	14	16	18	20	22
10 Feet	16.5	18.5	20.5	22.5	24.5	26.5	28.5	30.5	32.5	34.5	36.5	38.5
15 Feet	16.5	18.5	20.5	22.5	24.5	26.5	28.5	30.5	32.5	34.5	36.5	38.5
20 Feet	16.5	18.5	20.5	22.5	24.5	26.5	28.5	30.5	32.5	34.5	36.5	38.5
25 Feet	16.5	18.5	20.5	22.5	24.5	26.5	28.5	30.5	32.5	34.5	36.5	38.5
30 Feet	16.5	18.5	20.5	22.5	24.5	26.5	28.5	30.5	32.5	34.5	36.5	38.5

Minimum Required Fall Clearance, ft (Z) - Includes 1.5 foot Safety Margin  
See diagram for illustration of axes X, Y and Z.

XXX - Allowable Work Area

DO NOT REMOVE LABEL

XXX - Not Allowed Work Area Unless swing fall path is free of obstruction. A WARNING WORKING IN THIS AREA MAY RESULT IN SERIOUS INJURY OR DEATH.

**FALLTECH**  
**FT-R+**  
LEADING EDGE SYSTEM

Item # 412-06624 Rev A

## 9.0 Definitions

The following are general definitions of fall protection terms as defined by ANSI Z359.0-2012.

**Anchorage:** A secure connecting point or a terminating component of a fall protection system or rescue system capable of safely supporting the impact forces applied by a fall protection system or anchorage subsystem.

**Anchorage Connector:** A component or subsystem that functions as an interface between the anchorage and a fall protection, work positioning, rope access or rescue system for the purpose of coupling the system to the anchorage.

**Arrest Distance:** The total vertical distance required to arrest a fall. The arrest distance includes the deceleration distance and activation distance.

**Authorized Person:** A person assigned by the employer to perform duties at a location where the person will be exposed to a fall hazard.

**Available Clearance:** The distance from a reference point, such as the working platform, to the nearest obstruction that an authorized person might contact during a fall which, if struck, could cause injury.

**Capacity:** The maximum weight that a component, system or subsystem is designed to hold.

**Certification:** The act of attesting in writing that the criteria established by these standards or some other designated standard have been met.

**Certified Anchorage:** An anchorage for fall arrest, positioning, restraint or rescue systems that a qualified person certifies to be capable of supporting the potential fall forces that could be encountered during a fall.

**Clearance:** The distance from a specified reference point, such as the working platform or anchorage of a fall arrest system, to the lower level that a worker might encounter during a fall.

**Clearance Requirement:** The distance below an authorized person that must remain clear of obstructions in order to ensure that the authorized person does not make contact with any objects that would cause injury in the event of a fall.

**Competent Person:** An individual designated by the employer to be responsible for the immediate supervision, implementation and monitoring of the employer's managed fall protection program who, through training and knowledge, is capable of identifying, evaluating and addressing existing and potential fall hazards, and who has the employer's authority to take prompt corrective action with regard to such hazards.

**Component:** An element or integral assembly of interconnected elements intended to perform one function in the system.

**Connecting Subsystem:** An assembly, including the necessary connectors, comprised of all components, subsystems, or both, between the anchorage or anchorage connector and the harness attachment point.

**Connector:** A component or element that is used to couple parts of the system together.

**Deceleration Distance:** The vertical distance between the user's fall arrest attachment at the onset of fall arrest forces during a fall, and after the fall arrest attachment comes to a complete stop.

**Energy (Shock) Absorber:** A component whose primary function is to dissipate energy and limit deceleration forces which the system imposes on the body during fall arrest.

**Fall Arrest:** The action or event of stopping a free fall or the instant where the downward free fall has been stopped.

**Fall Hazard:** Any location where a person is exposed to a potential free fall.

**Free Fall:** The act of falling before a fall protection system begins to apply forces to arrest the fall.

**Free Fall Distance:** The vertical distance traveled during a fall, measured from the onset of a fall from a walking working surface to the point at which the fall protection system begins to arrest the fall.

**Harness, Full Body:** A body support designed to contain the torso and distribute the fall arrest forces over at least the upper thighs, pelvis, chest and shoulders.

**Horizontal Lifeline:** A component of a horizontal lifeline subsystem, consisting of a flexible line with connectors or other coupling means at both ends for securing it horizontally between two anchorages or anchorage connectors.

**Horizontal Lifeline Subsystem:** An assembly, including the necessary connectors, comprised of a horizontal lifeline component and, optionally, of: a) An energy absorbing component or, b) A lifeline tensioner component, or both. This subsystem is normally attached at each end to an anchorage or anchorage connector. The end anchorages have the same elevation.

**Lanyard:** A component consisting of a flexible rope, wire rope or strap, which typically has a connector at each end for connecting to the body support and to a fall arrester, energy absorber, anchorage connector or anchorage.

**Lanyard Connecting Subsystem:** An assembly, including the necessary connectors, comprised of a lanyard only, or a lanyard and energy absorber.

**Personal Fall Arrest System (PFAS):** An assembly of components and subsystems used to arrest a person in a free fall.

**Positioning:** The act of supporting the body with a positioning system for the purpose of working with hands free.

**Positioning Lanyard:** A lanyard used to transfer forces from a body support to an anchorage or anchorage connector in a positioning system.

**Qualified Person:** A person with a recognized degree or professional certificate and with extensive knowledge, training and experience in the fall protection and rescue field who is capable of designing, analyzing, evaluating and specifying fall protection and rescue systems.

**Self-Retracting Device (SRD):** A device that contains a drum wound line that automatically locks at the onset of a fall to arrest the user, but that pays out from and automatically retracts onto the drum during normal movement of the person to whom the line is attached.

**Snap Hook:** A connector comprised of a hook-shaped body with a normally closed gate or similar arrangement that may be opened to permit the hook to receive an object and, when released, automatically closes to retain the object.

**Swing Fall:** A pendulum-like motion that occurs during and/or after a vertical fall. A swing fall results when an authorized person begins a fall from a position that is located horizontally away from a fixed anchorage.

APPENDIX A

Table 1A: Specifications for FT-R+ Leading Edge SRL

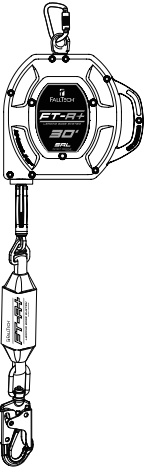
Model #	Lifeline Material	Working Length, Weight, and Housing Size	Materials and Specifications	Capacity and Standards	Class 2 SRL
TBD	7/32" (5.6mm) Diameter 7X19 Galvanized Steel Cable	TBD	Housing: Glass Reinforced Nylon	Single User Capacity for ANSI Compliance: 130 to 310 lbs. (59 to 141 kg)	
721730LER		30 ft (9.1 m) 15.0 lbs (6.8 kg) 10" X 10" (254 mm X 254 mm)	Anchorage Carabiner: 5,000 lbs (22.2 kN) with 3,600 lbs (16 kN) Gate Strength	Single User Capacity for CSA/OSHA Compliance: 130 to 420 lbs. (59 to 191 kg)	
TBD		TBD	Swivel Snap Hook: 5,000 lbs (22.2 kN) with 3,600 lbs (16 kN) Gate Strength	ANSI Z359.14-2021 Class 2 SRL  CSA Z259.2.2-17 SRL-LE  OSHA 1926.502 OSHA 1910.140	

**Table 1B: FallTech FT-R+ Class 2 Leading Edge SRL ANSI Performance Attributes**

Part #s and Conditions		Typical FallTech Performance for 130 to 310 lbs (59 to 141 kg) User			Typical FallTech Performance for 130 to 420 lbs (59 to 191 kg) User			ANSI Performance Requirements		
Part #	Anchorage Condition	Arrest Distance	Average Arrest Force	Maximum Arrest Force	Arrest Distance	Average Arrest Force	Maximum Arrest Force	Maximum Arrest Distance	Average Arrest Force *Conditioned	Maximum Arrest Force
TBD	Overhead Non-Leading Edge	TBD" (TBD m)	TBD lbf (TBD kN)	TBD lbf (TBD kN)	TBD" (TBD m)	TBD lbf (TBD kN)	TBD lbf (TBD kN)	42" (1.1 m)	1,575 lbf (7.0 kN)	
	Leading Edge Condition, Foot-Level with 5' (1.5m) Setback	TBD" (TBD m)	TBD lbf (TBD kN)	TBD lbf (TBD kN)	TBD" (TBD m)	TBD lbf (TBD kN)	TBD lbf (TBD kN)	N/A	N/A	
	Leading Edge Condition, Foot-Level with 0' Setback	TBD" (TBD m)	TBD lbf (TBD kN)	TBD lbf (TBD kN)	TBD" (TBD m)	TBD lbf (TBD kN)	TBD lbf (TBD kN)	N/A	N/A	
721730LER	Overhead Non-Leading Edge	42" (1.1 m)	1,068 lbf (4.8 kN)	1,376 lbf (6.1 kN)	44" (1.1 m)	924 lbf (4.1 kN)	1,309lbf (5.8 kN)	42" (1.1 m)	1,575 lbf (7.0 kN)	
	Leading Edge Condition, Foot-Level with 5' (1.5 m) Setback	74" (1.9 m)	707 lbf (3.1 kN)	1,222 lbf (5.4 kN)	94" (2.4 m)	675 lbf (3.0 kN)	1,206 lbf (5.4 kN)	N/A	N/A	1,800 lbs (8.0 kN)
	Leading Edge Condition, Foot-Level with 0' Setback	81" (2.1 m)	1,041 lbf (4.6 kN)	1,557 lbf (6.9 kN)	104" (2.6 m)	1,000 lbf (4.4 kN)	1,514 lbf (6.7 kN)	N/A	N/A	
TBD	Overhead Non-Leading Edge	TBD" (TBD m)	TBD lbf (TBD kN)	TBD lbf (TBD kN)	TBD" (TBD m)	TBD lbf (TBD kN)	TBD lbf (TBD kN)	42" (1.1 m)	1,575 lbf (7.0 kN)	
	Leading Edge Condition, Foot-Level with 5' (1.5m) Setback	TBD" (TBD m)	TBD lbf (TBD kN)	TBD lbf (TBD kN)	TBD" (TBD m)	TBD lbf (TBD kN)	TBD lbf (TBD kN)	N/A	N/A	
	Leading Edge Condition, Foot-Level with 0' Setback	TBD" (TBD m)	TBD lbf (TBD kN)	TBD lbf (TBD kN)	TBD" (TBD m)	TBD lbf (TBD kN)	TBD lbf (TBD kN)	N/A	N/A	

**Table 1C: FallTech FT-R+ SRL-LE CSA Performance Attributes**

Part #s and Conditions		Typical FallTech Performance			CSA Performance Requirements			
Part #	Anchorage Condition	SRD Class	Arrest Distance	Average Deployment Force	Maximum Arrest Force	Maximum Arrest Distance	Average Deployment Force	Maximum Arrest Force
TBD	Overhead Non-Leading Edge	CSA SRL-LE	TBD m (TBD ft)	N/A	TBD kN (TBD lbf)	1.2m (3.9 ft)	N/A	8.0 kN (1,800 lbf)
	Leading Edge Condition, Foot-Level with 5' (1.5m) Setback		TBD m (TBD ft)	TBD kN (TBD lbf)	TBD kN (TBD lbf)	N/A	6.0 kN (1,350 lbf)	
721730LER	Overhead Non-Leading Edge		0.8 m (34")	N/A	6.1 kN (1,386 lbf)	1.2m (3.9 ft)	6.0 kN (1,350 lbf)	
	Leading Edge Condition, Foot-Level with 5' (1.5 m) Setback		2.2 m (88")	3.9 kN (875 lbf)	5.9 kN (1,328 lbf)	N/A	6.0 kN (1,350 lbf)	
TBD	Overhead Non-Leading Edge		TBD m (TBD ft)	N/A	TBD kN (TBD lbf)	1.2m (3.9 ft)	N/A	
	Leading Edge Condition, Foot-Level with 5' (1.5 m) Setback		TBD m (TBD ft)	TBD kN (TBD lbf)	TBD kN (TBD lbf)	N/A	6.0 kN (1,350 lbf)	

**Table 1D: FT-R+ SRL SpeedLine Replacement Lifeline Part Numbers**

Part #	Description
5048	FT-R+ Speedline Tool Set
721730LERK	30' FT-R+ SpeedLine Replacement Lifeline