

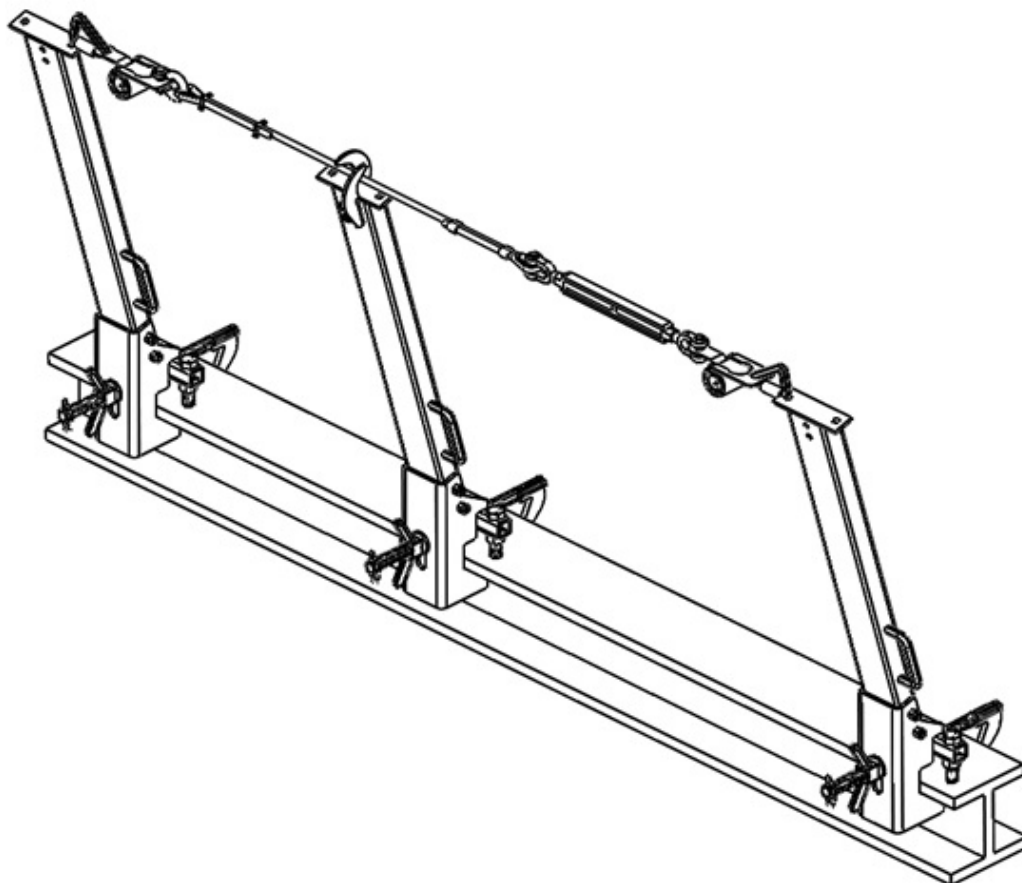

# Steel GRIP<sup>®</sup>

Temporary Cable Horizontal Lifeline

User Instruction Manual



This manual is intended to meet the Manufacturer's Instructions as required by the American National Standards Institute (ANSI) Z359 and should be used as part of an employee training program as required by the Occupational Safety and Health Administration (OSHA).

## Table of Contents

1.0	Warnings and Important Information .....	3
2.0	Application .....	4
3.0	System Requirements .....	8
4.0	Installation and Use .....	9
5.0	Maintenance, Service and Storage .....	13
6.0	Inspection .....	13
7.0	Labels .....	14
8.0	Definitions .....	15
	Appendix A .....	17

For the purposes of this manual, the FallTech SteelGrip® Temporary Horizontal Lifeline may be referred to as the HLL, the system or the lifeline.

Throughout this manual, ANSI Z359.0-2012 fall protection words, phrases and terms are used. These terms are all formally defined in Section 8.0 of this manual.

## 1.0 Warnings and Important Information

### **WARNING**

- Avoid moving machinery, thermal, electrical, and/or chemical hazards as contact may cause serious injury or death.
- Avoid swing falls.
- Follow the weight restrictions and recommendations in this manual.
- Remove from service any equipment subjected to fall arrest forces.
- Remove from service any equipment that fails inspection.
- Do not alter or intentionally misuse this equipment.
- Consult FallTech when using this equipment in combination with components or subsystems other than those described in this manual.
- Do not connect rebar hooks, large carabiners, or large snap hooks to the FBH dorsal D-rings as this may cause a roll-out condition and/or unintentional disengagement.
- Avoid sharp and/or abrasive surfaces and edges.
- Use caution when performing arc welding. Arc flash from arc welding operations, including accidental arcs from electrical equipment, can damage equipment and are potentially fatal.
- Examine the work area. Be aware of the surroundings and workplace hazards that may impact safety, security, and the functioning of fall arrest systems and components.
- Hazards may include, but are not limited to, cable or debris tripping hazards, equipment failures, personnel mistakes, or moving equipment such as carts, barrows, fork lifts, cranes, or dollies. Do not allow materials, tools, or equipment in transit to contact any part of the fall arrest system.
- Do not work under suspended loads.

### **IMPORTANT**

This product is part of a personal fall arrest, restraint, work positioning, suspension, or rescue system. A Personal Fall Arrest System (PFAS) is typically composed of an anchorage and a Full Body Harness (FBH), with a connecting device, i.e., a Shock Absorbing Lanyard (SAL), or a Self-Retracting Lanyard (SRL), attached to the dorsal D-ring of the FBH.

These instructions must be provided to the worker using this equipment. The worker must read and understand the manufacturer's instructions for each component or part of the complete system. Manufacturer's instructions must be followed for proper use, care, and maintenance of this product. These instructions must be retained and be kept available for the worker's reference at all times. Alterations or misuse of this product, or failure to follow instructions, may result in serious injury or death.

A Fall Protection Plan must be on file and available for review by all workers. It is the responsibility of the worker and the purchaser of this equipment to assure that users of this equipment are properly trained in its use, maintenance, and storage. Training must be repeated at regular intervals. Training must not subject the trainee to fall hazards.

Consult a doctor if there is reason to doubt your fitness to safely absorb the shock of a fall event. Age and fitness seriously affect a worker's ability to withstand falls. Pregnant women or minors must not use this equipment.

ANSI limits the weight of fall protection equipment users to a maximum of 310 lbs. Products in this manual may have a rated capacity exceeding ANSI capacity limits. Heavy users experience more risk of serious injury or death due to falls because of increased fall arrest forces placed on the user's body. In addition, the onset of suspension trauma after a fall event may be accelerated for heavy users.

The user of the equipment discussed in this manual must read and understand the entire manual before beginning work.

NOTE: For more information consult the ANSI Z359 body of standards.

## 2.0 Application

**2.1 Purpose:** The purpose of the FallTech SteelGrip® Temporary Cable HLL is to provide horizontal mobility for workers exposed to fall hazards and is designed as an anchorage subsystem for the attachment of up to two PFASs. The HLL is adjustable up to 100' in length for a single span system and up to 360' in length for a multi-span system. The system is designed to be used as part of a complete PFAS. See Figure 1.

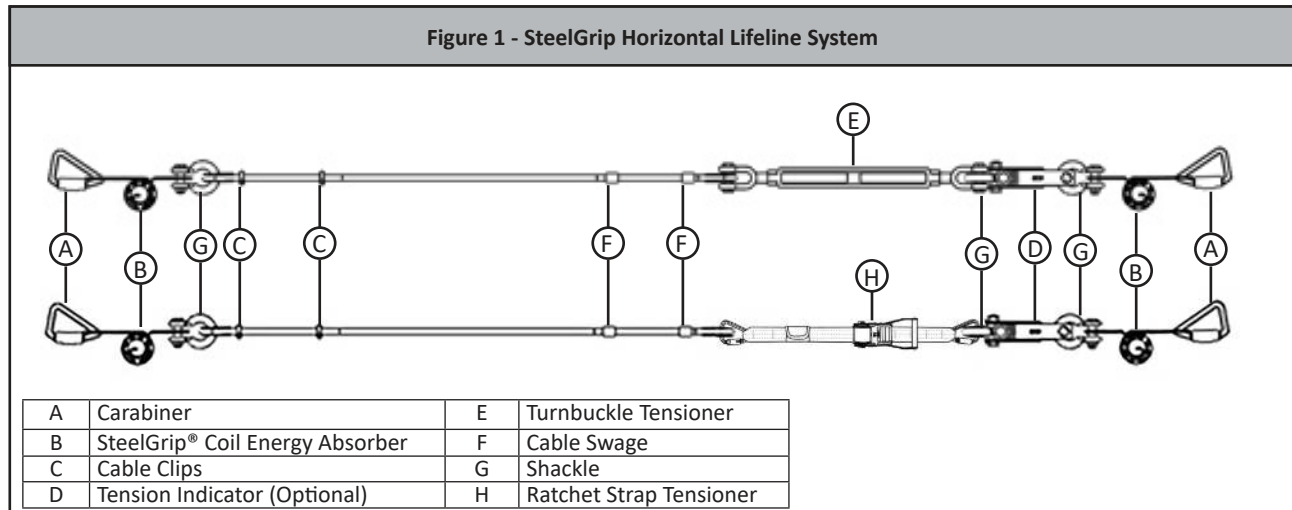

When properly tensioned, the lifeline will react to a fall event of up to two workers by combining the energy absorbing properties of the lifeline cable, the SteelGrip® Coil Energy Absorber, and the worker's personal energy absorber. During a fall event, the SteelGrip® Coil Energy Absorber will deploy and elongate to safely and predictably absorb the energy of the fall event. The elongation of the SteelGrip® Coil Energy Absorber along with the stretch of the lifeline and the expansion of the user's PFAS will result in reduced forces to the anchor and to the user's body.

**2.2 Application Limits:** The FallTech SteelGrip® Temporary Cable HLL is a dynamic anchorage subsystem that will vary in its performance depending upon the length of the system, the number of workers attached and the type of PFAS being used. Care should be taken to understand the capacity of the system, minimum required fall clearance, anchorage strength requirements, total allowable free fall, total allowable fall clearance, and how the user's PFAS will deploy during a fall event. Longer HLL spans will generate more lifeline deflection and sag during a fall event and will result in greater clearance requirements. See Figure 2.

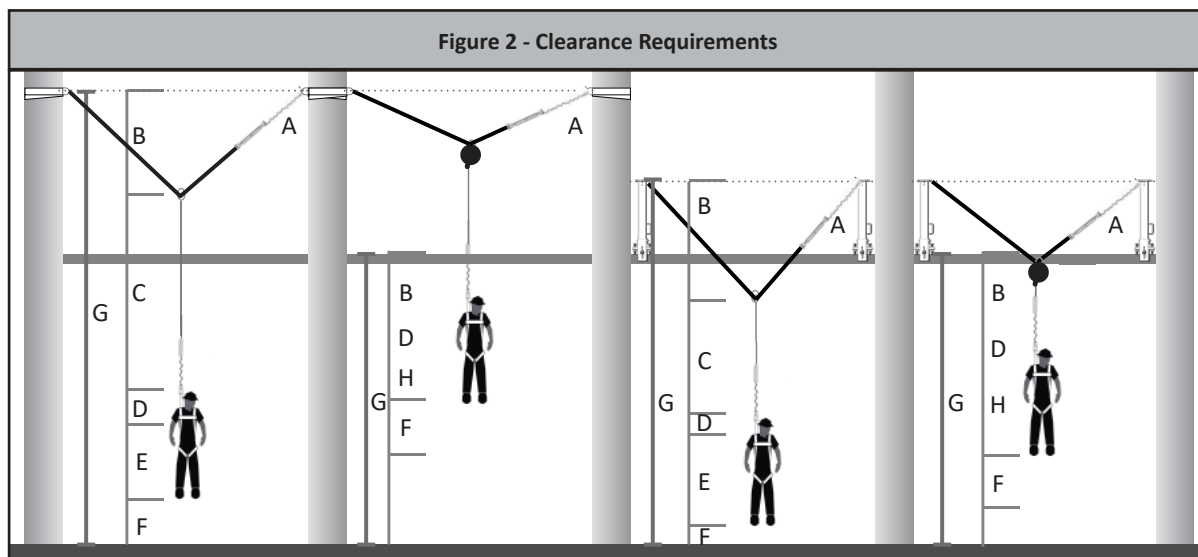

A	Deployed In-Line Energy Absorber	E	Height of Worker
B	Dynamic Lifeline Sag	F	Safety Factor
C	Deployed SAL	G	Total Required Fall Clearance
D	D-ring Shift and Harness Stretch	H	Total SRD Deceleration Distance from User's Manual*

\* If SRD Deceleration Distance is unknown, use 2 feet for ANSI Z359.14-2014 Class A SRDs, 4-1/2 feet for ANSI Z359.14-2014 Class B SRDs, or 3-1/2 feet for ANSI Z359.14-2021 Class 1 or 2 SRDs.

- 2.3 System Capacity:** The FallTech SteelGrip® Temporary Cable HLL maximum capacity is two workers simultaneously, with each worker weighing no more than 310 Lbs. inclusive of clothing, tools, etc. For multiple span systems, maximum capacity is two workers per span with a maximum of six total workers per system, see Figures 3 and 4. Systems utilizing the Ratchet Strap Tensioner shall be limited to single span applications with a maximum of two workers.
- 2.4 Anchorage Requirements:** End anchors selected for use with this system must be a minimum of 5,000 lbs. (22.2 kN).
- 2.5 Total Allowable Free Fall:** OSHA limits free fall to 6' or less. The HLL system described in this manual is designed to be used overhead and free fall should be limited to 6' unless otherwise specified by a specific anchorage solution.
- 2.6 PFAS Selection:** Only FallTech PFASs may be used in conjunction with this HLL system. The HLL may be used with FallTech energy absorbing lanyards, FallTech self-retracting devices, and FallTech fall arrester connecting subsystems.
- 2.7 Clearance Requirements:** The FallTech SteelGrip® Temporary Cable HLL is designed to react to a fall event by elongating and deflecting to absorb energy. PFAS attached to the HLL will also elongate during a fall event. It is important to understand clearance requirements prior to installation and use of the system. See tables and charts below for calculating minimum required fall clearance.
- 2.7.1 Minimum Required Fall Clearance for One Worker w/SAL**

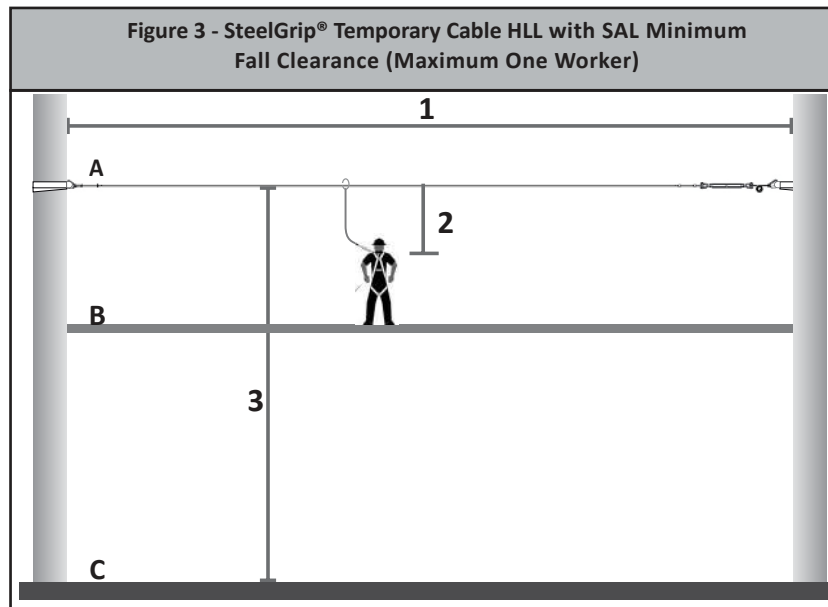

SteelGrip® Temporary Cable HLL with SAL Minimum Required Fall Clearance	
310 lbs. Maximum User Capacity	Max. One Worker
1	Find Span Length in Table Below
2	Find Freefall Distance in Table Below
3	Required Fall Clearance at the intersection of Span Length and Freefall Distance (see table below)
A. Overhead Anchorage B. Walking/Working Surface C. Nearest Lower Level or Obstruction	
* Work below HLL to avoid Swing Fall	

		Freefall Distance (feet)							
		0	1	2	3	4	5	6	7*
Span Length (feet)	0 - 30	15.0'	16.0'	17.0'	18.0'	19.0'	20.0'	21.0'	22.0'
	31 - 40	16.0'	17.0'	18.0'	19.0'	20.0'	21.0'	22.0'	23.0'
	41 - 50	17.0'	18.0'	19.0'	20.0'	21.0'	22.0'	23.0'	24.0'
	51 - 60	18.0'	19.0'	20.0'	21.0'	22.0'	22.5'	24.0'	25.0'
	61 - 70	18.5'	19.5'	20.5'	21.5'	22.5'	23.5'	24.5'	25.5'
	71 - 80	19.5'	20.5'	21.5'	22.5'	23.5'	24.5'	25.5'	26.5'
	81 - 90	20.0'	21.0'	22.0'	23.0'	24.0'	25.0'	26.0'	27.0'
	91 - 100	20.5'	21.5'	22.5'	23.5'	24.5'	25.5'	26.5'	27.5'

\* 7' Freefall Distance scenario is only allowed when the SteelGrip® Temporary Cable HLL attached to the FallTech SteelGrip® Stanchion. Freefall should be limited to 6' or less when used with any other anchorage connector.

2.7.2 Minimum Required Fall Clearance for Two Workers w/SAL

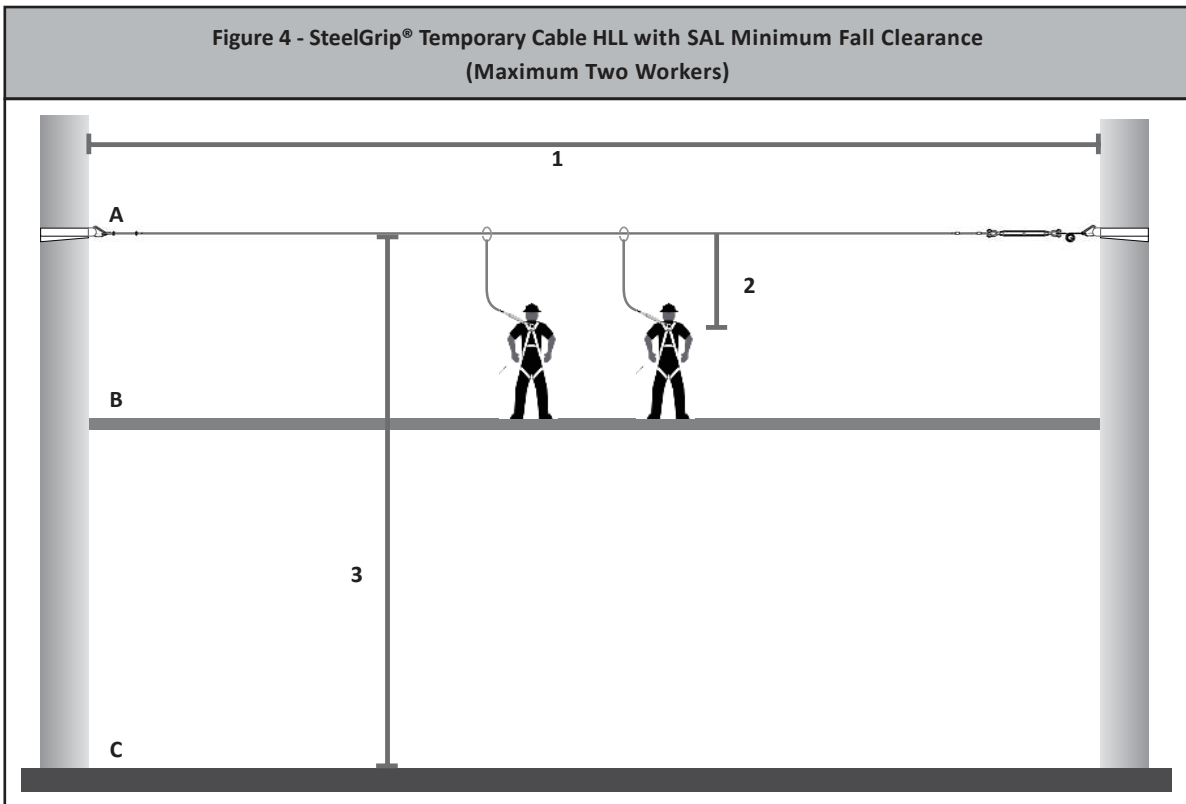

SteelGrip® Temporary Cable HLL with SAL Minimum Required Fall Clearance	
310 lbs. Maximum User Capacity Each	
Max. Two Workers	
1	Find Span Length in Table Below
2	Find Freefall Distance in Table Below
3	Required Fall Clearance at the intersection of Span Length and Freefall Distance (see table below)
A. Overhead Anchorage B. Walking/Working Surface C. Nearest Lower Level or Obstruction	
* Work below HLL to avoid Swing Fall	

		Freefall Distance (feet)							
		0	1	2	3	4	5	6	7 *
Span Length (feet)	0 - 30	17.0'	18.0'	19.0'	20.0'	21.0'	20.0'	23.0'	24.0'
	31 - 40	18.5'	19.5'	20.5'	21.5'	22.5'	23.5'	24.5'	25.5'
	41 - 50	19.5'	20.5'	21.5'	22.5'	23.5'	24.5'	25.5'	26.5'
	51 - 60	21.0'	22.0'	23.0'	24.0'	25.0'	26.0'	27.0'	28.0'
	61 - 70	22.5'	23.5'	24.5'	25.5'	26.5'	27.5'	28.5'	29.5'
	71 - 80	24.5'	25.5'	26.5'	27.5'	28.5'	29.5'	30.5'	31.5'
	81 - 90	26.0'	27.0'	28.0'	29.0'	30.0'	31.0'	32.0'	33.0'
	91 - 100	27.5'	28.5'	29.5'	30.5'	31.5'	32.5'	33.5'	34.5'

\* 7' Freefall Distance scenario is only allowed when the SteelGrip® Temporary Cable HLL is attached to the FallTech SteelGrip® Stanchion. Freefall should be limited to 6' or less when used with any other anchorage connector.

**2.7.3 Minimum Required Fall Clearance for up to Two Workers w/SRDs**

When attaching up to two Self-Retracting Devices (SRD) to the FallTech SteelGrip® Cable HLL system shown in Figure 5, it is permissible to calculate the required clearance below the working surface by including the typical SRD deceleration distances detailed in the SRD user’s instruction manual. Calculating total clearance requirements using typical performance attributes for the SRD will generally result in reduced clearance requirements.

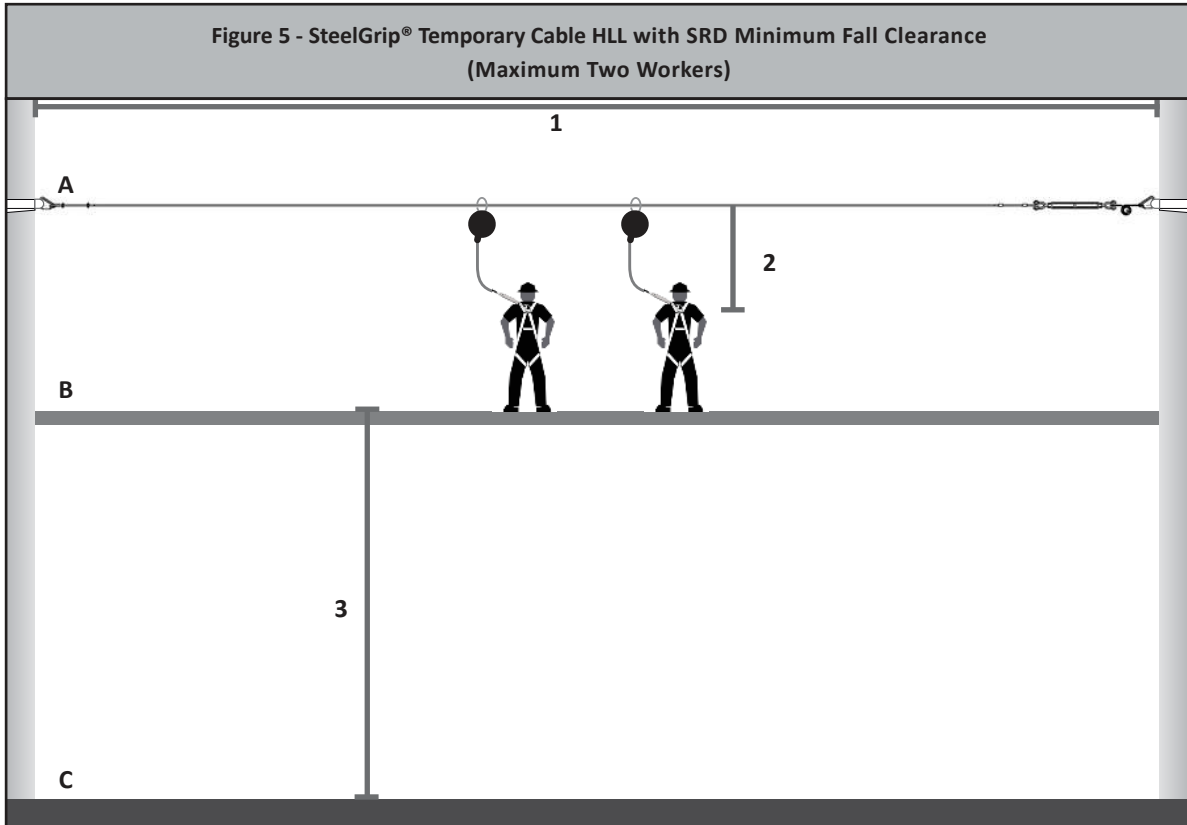

SteelGrip® Temporary Cable HLL with SRD Minimum Required Fall Clearance		
310 lbs. Maximum User Capacity Each		Max. Two Workers
<b>A</b>		Final Vertical HLL Sag (see chart on the following page)
<b>B</b>		Total SRD Deceleration Distance from User Instruction Manual*
<b>C</b>	<b>1 ft</b>	D-ring Shift and Harness Stretch
<b>D</b>	<b>3 ft</b>	Safety Factor
<b>E</b>		<b>Sub Total - Minimum Required Fall Clearance</b> for direct overhead use of SRD (sum of A, B, C and D only)
<b>F</b>	<b>1 ft</b>	<b>* Additional Fall Clearance Calculation</b> due to the use of stanchions
<b>G</b>		<b>Total Minimum Required Fall Clearance When Using Stanchions - (Sum of E and F)</b>
1. Overhead Anchorage    2. Walking/Working Surface    3. Nearest Lower Level or Obstruction		
* If SRD Deceleration Distance is unknown, use 2 feet for ANSI Z359.14-2014 Class A SRDs, 4-1/2 feet for ANSI Z359.14-2014 Class B SRDs, or 3-1/2 feet for ANSI Z359.14-2021 Class 1 or 2 SRDs.		
** Work below HLL to avoid Swing Fall		

Final Vertical HLL Sag for Fall Clearance Calculation When Using SRD(s)		
	One Worker	Two Workers
0 - 30	4.5'	6.5'
31 - 40	5.5'	8.0'
41 - 50	6.0'	9.0'
51 - 60	7.0'	10.5'
61 - 70	8.0'	12.0'
71 - 80	9.0'	14.0'
81 - 90	9.5'	16.0'
91 - 100	10.5'	18.0'

For worst case clearance calculations the user of the FallTech SteelGrip® Cable HLL systems may opt to use the ANSI Z359.14 maximum deceleration distances when determining clearance requirements. ANSI Z359.14-2014 allows up to 24" of deceleration for Class A SRDs and up to 54" of deceleration for Class B SRDs. ANSI Z359.14-2021 allows up to 42" of deceleration for Class 1 or 2 SRDs. The charts below demonstrate clearance requirements below the working surface when using the FallTech SteelGrip® Temporary Cable HLL and attaching either 2014 Class A/B or 2021 Class 1/2 SRDs to the HLL. Overhead anchorage only.

Required Clearance When Connected to HLL Using ANSI Z359.14-2014 Class A SRDs			Required Clearance When Connected to HLL Using ANSI Z359.14-2014 Class B SRDs			Required Clearance When Connected to HLL Using ANSI Z359.14-2021 Class 1/2 SRDs		
Span Length (feet)	One Worker	Two Workers	Span Length (feet)	One Worker	Two Workers	Span Length (feet)	One Worker	Two Workers
	0 - 30	10.5'		12.5'	0 - 30		13.0'	15.0'
31 - 40	11.5'	14.0'	31 - 40	14.0'	16.5'	31 - 40	13.0'	15.5'
41 - 50	12.0'	15.0'	41 - 50	14.5'	17.5'	41 - 50	13.5'	16.5'
51 - 60	13.0'	16.5'	51 - 60	15.5'	19.0'	51 - 60	14.5'	18.0'
61 - 70	14.0'	18.0'	61 - 70	16.5'	20.5'	61 - 70	15.5'	19.5'
71 - 80	15.0'	20.0'	71 - 80	17.5'	22.5'	71 - 80	16.5'	21.5'
81 - 90	15.5'	22.0'	81 - 90	18.0'	24.5'	81 - 90	17.0'	23.5'
91 - 100	16.5'	24.0'	91 - 100	19.0'	26.5'	91 - 100	18.0'	25.5'

**2.8 Rescue:** The FallTech SteelGrip® Temporary Cable HLL is part of a complete PFAS. It is not intended as a rescue device. Users of this system presents a wide variety of potential rescue scenarios. Users of this system should understand their work environment and develop a rescue plan accordingly. It is recommended that a trained on-site rescue team be present during use of the system.

### 3.0 System Requirements

- 3.1 Anchorage Strength:** End anchors selected for use with this system must have a minimum rating of 5,000 lbs. (22.2 kN).
- 3.2 Structure:** The mounting points for the anchorage must be capable of supporting no less than 5000lbs, see Figure 6.

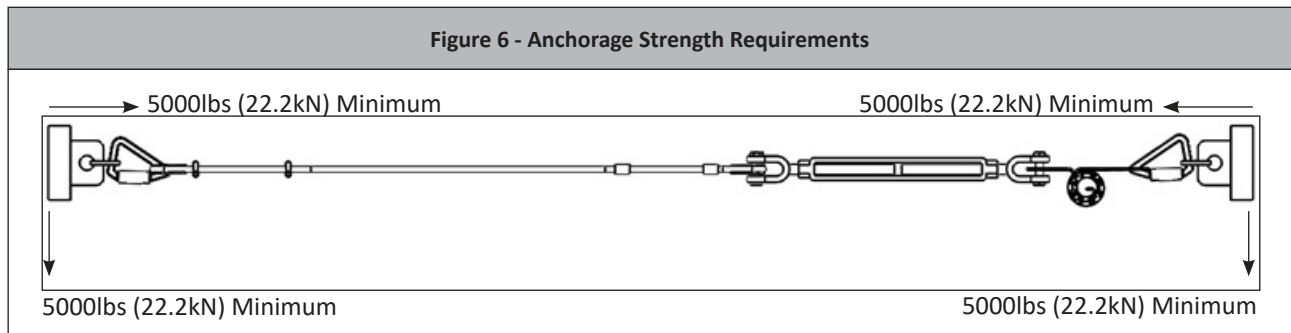

- 3.2 Compatibility of Connectors:** Connectors are considered to be compatible with connecting elements when they have been designed to work together in such a way that their sizes and shapes do not cause their gate mechanisms to inadvertently open regardless of how they become oriented. Contact FallTech if you have any questions about compatibility. Connectors must be compatible with the anchorage or other system components. Do not use equipment that is not compatible. Non-compatible connectors may unintentionally disengage. Connectors must be compatible in size, shape, and strength. Self-closing, self-locking snap hooks and carabiners are specified by OSHA and ANSI Z359.12.
- 3.3 Compatibility of Components:** Equipment is designed for use with approved components and subsystems only. Substitutions or replacements made with non-ANSI Z359 compliant components or subsystems may jeopardize compatibility of equipment and may affect the safety and reliability of the complete system. Ensure compatibility between the connectors if non-FallTech components are used for fall protection.
- 3.4 Connectors:** Only use self-locking snap hooks, rebar hooks, and carabiners with this equipment. Only use connectors that are suitable to each application. Ensure all connections are compatible in size, shape and strength. Do not use equipment that is not compatible. Visually ensure all connectors close and lock completely. Connectors (snap hooks, rebar hooks, and carabiners) are designed for use only as specified in this manual.

## 4.0 Installation and Use

*The FallTech SteelGrip® Temporary Cable HLL is sold in a variety of kits and configurations. The assembly instructions listed below may refer to components not included in each kit. For a list of parts included in each kit, see Appendix A.*

- 4.1 Plan the Personal Fall Arrest System (PFAS):** Inspect the HLL subsystem before each use in accordance with the procedures detailed in Section 6. Examine the work area and take action to address hazards. Falls are a serious hazard when working at height. Training and equipment are the tools of fall hazard management. There are several closely related facets of fall hazard management with a PFAS;
- Anchor Point Selection
  - Anchorage Connector
  - Deceleration Device
    - Maximum Arrest Force
    - Deceleration Distance
    - Minimum Required Fall Clearance (MRFC)
  - Body Wear
  - Rescue
- 4.2 Anchor Point Selection:** Select a suitable anchor point. Consider the area where the work is being performed. In an overhead anchorage condition, the area below the anchorage is the work zone. Lateral movement away from the anchorage is hazardous. As distance from the anchor increases, the work zone expands, and so does the hazard. Work zone expansion is measured in feet and has a direct influence on user safety. Always work as close to the anchor as possible. End anchors selected for use with this system must be a minimum of 5,000 lbs. (22.2 kN). See list of compatible FallTech anchors in Appendix A.
- 4.3 Anchorage Connector:** Anchorage Connectors used as part of a PFAS should be designed for use with specified anchor points and compatible with the PFAS components and connectors to be used in the assembly of a complete PFAS. Care should be taken to ensure proper assembly, installation and maintenance of all Anchorage Connectors to be used when planning a PFAS. Failure to inspect, assemble, install and/or maintain Anchorage Connectors could result in injury or death.
- 4.4 Connectors/Deceleration Devices:** Connectors and Deceleration Devices such as Shock Absorbing Lanyards, Self-Retracting Devices/Lifelines, and Fall Arrestor Connector Subsystems (Vertical Lifeline/Rope Grab Combinations) are designed to connect the user's body wear to the Anchorage Connector and/or Anchor Point of a Personal Fall Arrest System.
- 4.5 Product Assembly and Installation:** System installation requires end anchor points that are a minimum of 5000 Lbs. in both vertical and horizontal directions. The lifeline should be installed to limit free fall to 6' or less\*. When using SRDs the lifeline must be positioned overhead\*. The horizontal lifeline should be positioned in a manner to minimize free fall while allowing ease of use. Movement away from the lifeline should be limited to reduce the potential for swing fall. Lifeline end anchors should be installed at approximately the same elevation so that the lifeline itself is not sloped more than 5 degrees.

For system length planning using the turnbuckle tensioner, the fully closed length of non-cable lifeline components is 4 feet (carabiner, shackles, indicator, and turnbuckle). For system length planning using the Ratchet Strap Tensioner, the maximum tensioner length is 8 feet.

System should be set up such that the final length of the Ratchet Strap Tensioner in the fully tensioned system is as short as possible.

\* When using SteelGrip® Stanchions as end anchors for this system, free fall may exceed 6' when using a Energy Absorbing Lanyard (EAL), see Section 2.7. SRDs are acceptable for use as personal energy absorbers.

## 4.6 Lifeline Component Assembly

### 4.6.1 Lifeline Component Assembly - Turnbuckle Tensioner

Step 1: Attach a carabiner to one end of the SteelGrip® Coil Energy Absorber as shown in Figure 7.

Step 2: Remove cotter pins, unthread nuts, and remove bolts of two shackles. Attach a shackle on either side of the FallTech Tension Indicator. Align one shackle with the remaining hole of the SteelGrip® Coil Energy Absorber, insert the shackle bolts, thread on and tighten nuts, and insert cotter pins into both shackles as shown in Figure 8.

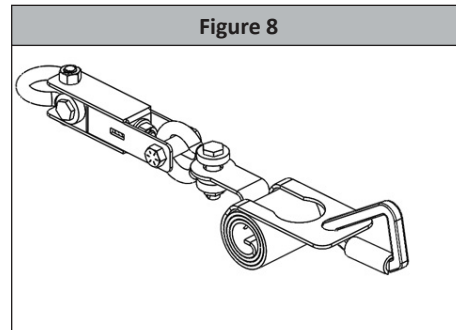
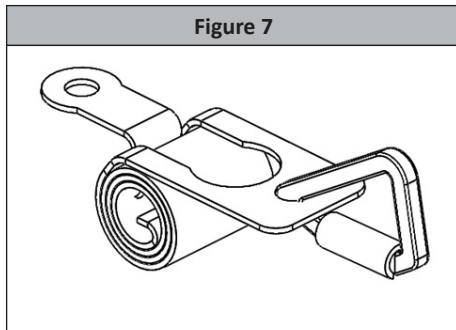

Step 3: Rotate the body of the turnbuckle to expand the connection points away from each other as shown in Figure 9. Being sure the jaws are expanded equally on both sides and that there are still threads visible inside the turnbuckle body.

Step 4: Remove the cotter pins from the bolts in the turnbuckle. Then, unthread the nuts and remove the bolts.

Step 5: Align the jaws of one end of the turnbuckle with the open shackle on the FallTech Tension Indicator. Insert a turnbuckle bolt through the aligned holes, thread on the nut and insert the cotter pin as shown in Figure 10.

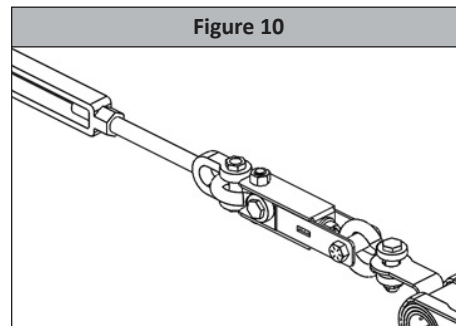
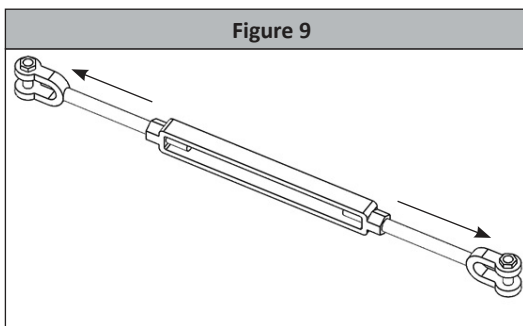

Step 6: Align the other jaw of the turnbuckle with the termed end of the cable. Insert a turnbuckle bolt through the aligned holes, thread on the nut and insert the cotter pin as shown in Figure 11.

Step 7: At the appropriate length, term the cable by wrapping the cable around the thimble, attach the wire rope clips as shown in Figure 12. Install one clip at the base of the thimble and one clip 3" away from other clip. There should be at least 8" of excess cable beyond the second wire rope clip. Wire rope clips shall be tightened to 45 in-lbs. using a torque wrench fitted with 3/4" socket.

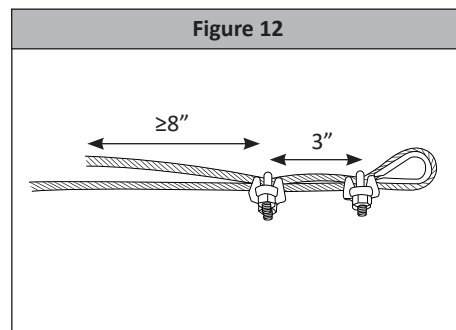
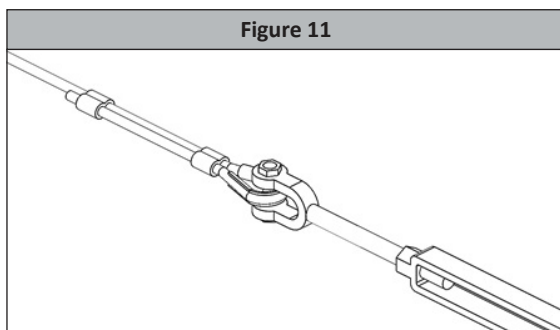

Step 8: Attach the second carabiner to the thimble end of the cable as shown in Figure 13.

*If the span is 60' or less, the system is ready to be installed. If the span is greater than 60', continue to step 9.*

Step 9: Remove the cotter pin of a shackle, unthread the nut and remove the bolt. Insert the shackle through the thimble end of the cable. Align the shackle holes with the hole in the second SteelGrip® Coil Energy Absorber. Insert the shackle bolt, thread on nut and insert cotter pin. See Figure 14.

Step 10: Attach the second carabiner to the other end of the SteelGrip® Coil Energy Absorber as shown in Figure 15.

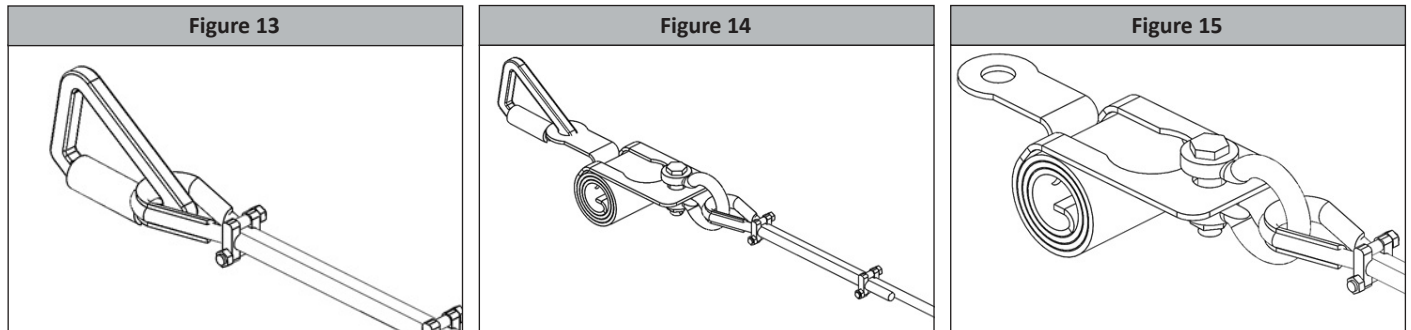

#### 4.6.2 Lifeline Component Assembly - Ratchet Strap Tensioner

Step 1: Attach a carabiner to one end of the SteelGrip® Coil Energy Absorber as shown in Figure 16.

Step 2: Remove cotter pins, unthread nuts, and remove bolts of two shackles. Attach a shackle on either side of the FallTech Tension Indicator. Align one shackle with the remaining hole of the SteelGrip® Coil Energy Absorber, insert the shackle bolts, thread on and tighten nuts, and insert cotter pins into both shackles as shown in Figure 17.

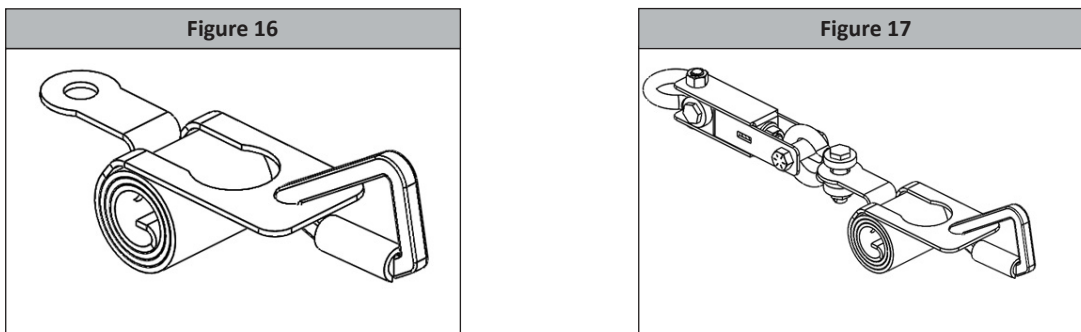

Step 3: Connect one carabiner of the Ratchet Strap Tensioner to the shackle on the tension indicator. Ratchet Strap Tensioner mechanism should be disengaged completely and locked in the open position. See Figure 18 for Ratchet Strap Tensioner functions.

Step 4: Connect the opposite side carabiner of the Ratchet Strap Tensioner to the manufacturer termed end of the cable lifeline.

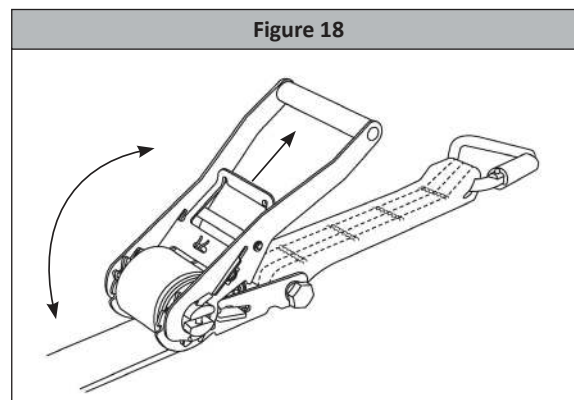

- Step 5: At the appropriate length, term the cable by wrapping the cable around the thimble, attach the wire rope clips as shown in Figure 12. Install one clip at the base of the thimble and one clip 3" away from other clip. There should be at least 8" of excess cable beyond the second wire rope clip. Wire rope clips shall be tightened to 45 in-lbs. using a torque wrench fitted with 3/4" socket.
- Step 6: Attach the second carabiner to the thimble end of the cable as shown in Figure 13.

***If the span is 60' or less, the system is ready to be installed. If the span is greater than 60', continue to step 9.***

- Step 7: Remove the cotter pin of a shackle, unthread the nut, and remove the bolt. Insert the shackle through the thimble end of the cable. Align the shackle holes with the hole in the second SteelGrip Coil Energy Absorber. Insert the shackle bolt, thread on nut, and insert cotter pin. See Figure 14.
- Step 8: Attach the second carabiner to the other end of the SteelGrip Coil Energy Absorber as shown in Figure 15.

**4.7 Product Installation Using The FallTech SteelGrip® Stanchions (Single or Multiple Span):**

- Step 1: The HLL system described in this manual is designed for use with the FallTech SteelGrip® Stanchions, which provide a minimum two to one safety factor relative to the loads applied by the system, see Figure 20. In order to reduce the required fall clearance, the use of intermediate stanchions to reduce span length is recommended. For more details see the **FallTech SteelGrip® Stanchion User Instruction Manual**. Systems utilizing the Ratchet Strap Tensioner and stanchions shall be limited to single span applications. See section 4.8 for instructions on tensioning system. System loads in Figure 19 still apply.

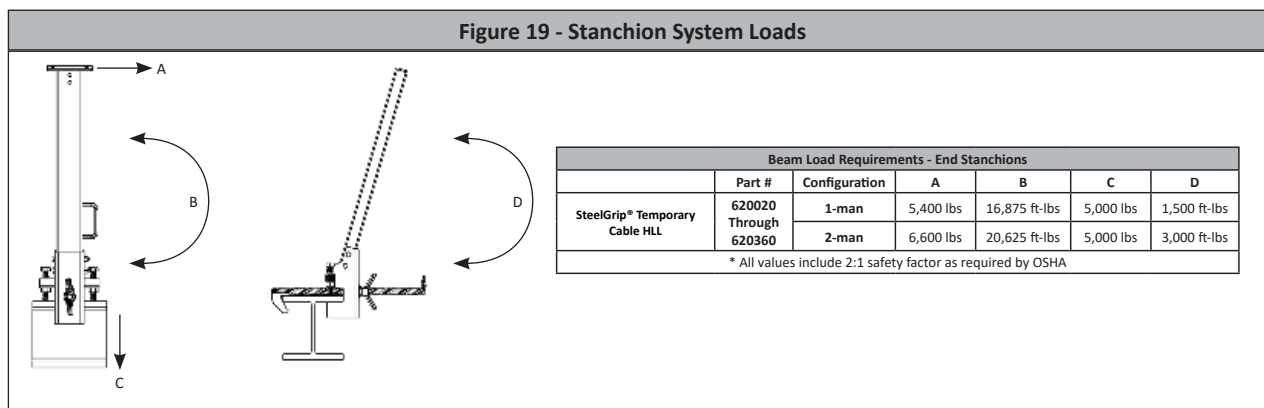

**Note:** *The maximum single span length when using stanchions is 60', see Figure 20. The overall system length can be increased by using intermediate stanchions to create multiple spans in at most 60' increments. For multiple spans two FallTech SteelGrip® Coil Energy Absorbers must be used, see Figure 21.*

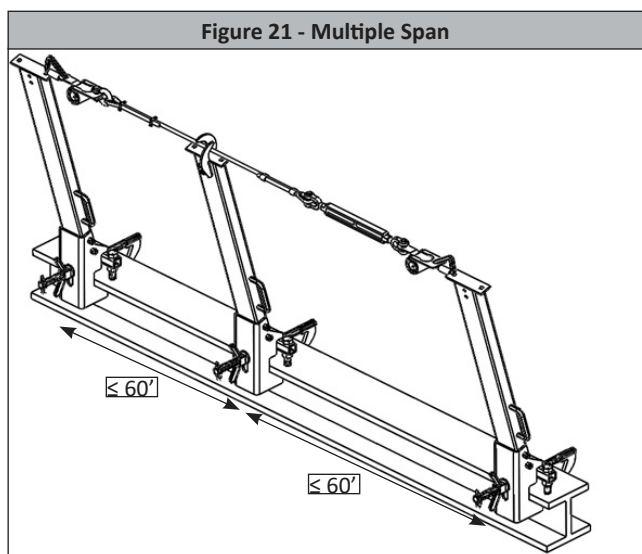
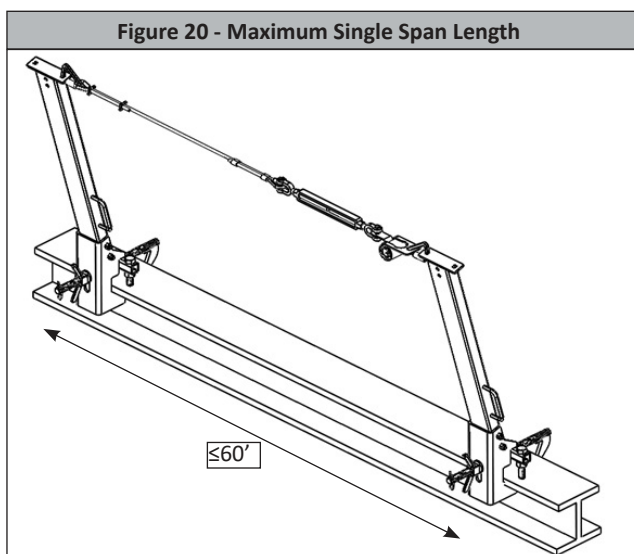

Step 2: Secure the HLL system to the end stanchions using the provided end attachment carabiners as shown in Figure 22.

Step 3: For single span systems, skip to step 4. For multiple span systems:

Ensure the pass-through brackets are installed per the instructions in the FallTech SteelGrip® Stanchion User Manual. Ensure that the lifeline passes through the intermediate stanchion's pass through brackets as shown in Figure 23.

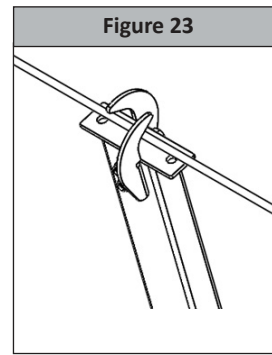
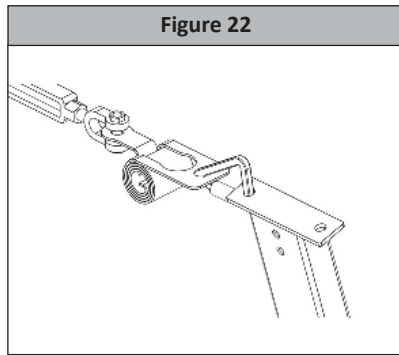

Step 4: Holding the cable side jaw of the turnbuckle to prevent the lifeline from twisting, use a tool to rotate the turnbuckle. Rotate the turnbuckle so that the jaws draw toward each other, as shown in Figure 24. Tighten the turnbuckle until the indicator is located in the center green section of the window, as shown in Figure 25.

Step 5: Once properly tensioned, the lifeline subsystem can be used.

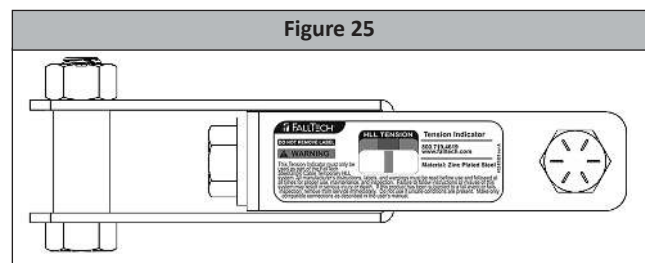
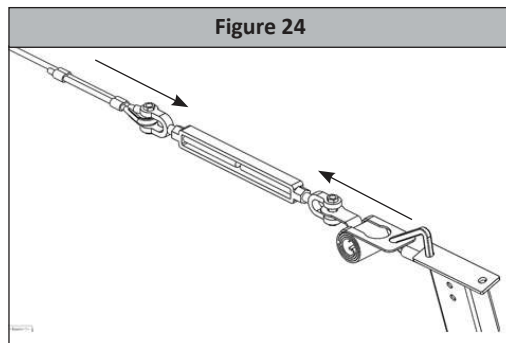

#### 4.8 Product Installation (Single Span):

Step 1: Determine the locations of the end anchorage connectors. The anchorage selected for a PFAS must have the strength to sustain a static load applied in the direction permitted by the PFAS of at least two times the maximum arrest force permitted when certification exists, or 5,000 lbs. (22.2 kN) in the absence of certification.

**Note:** *Single span lengths 60' and shorter use a single FallTech SteelGrip® Coil Energy Absorber, see Figure 26 .  
Single span lengths longer than 60' must use two FallTech SteelGrip® Coil Energy Absorbers, see Figure 27.*

Figure 26 - Single Span up to 60'

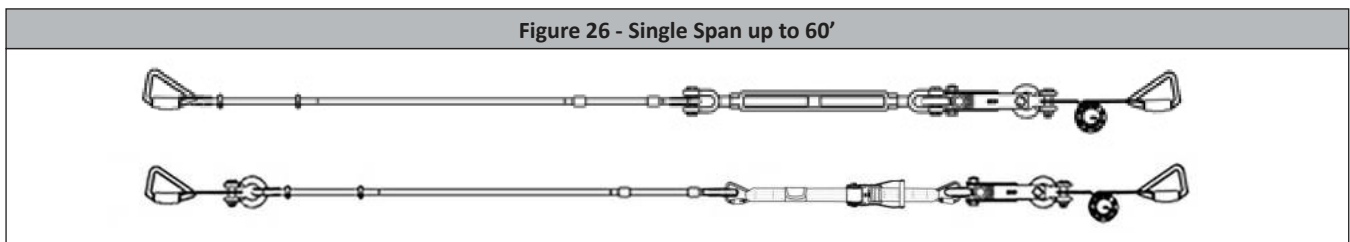
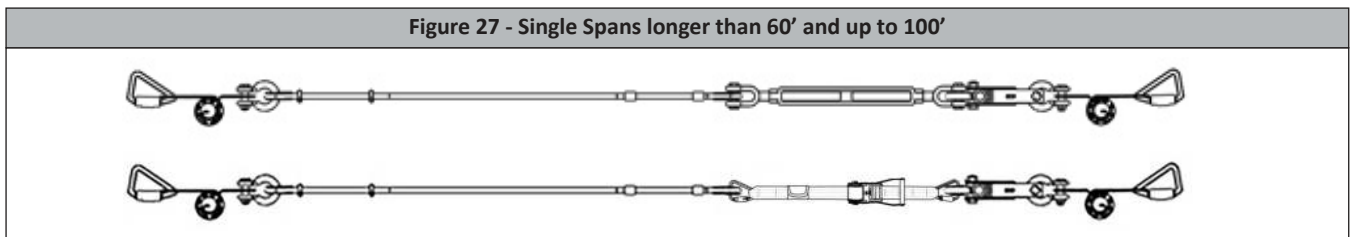

Figure 27 - Single Spans longer than 60' and up to 100'



Step 2: Install the end anchorage connectors.

Step 3: Secure the HLL system to the anchorage connectors with the provided end attachment carabiners.

Step 4: For systems with turnbuckle tensioner:

Holding the cable side jaw of the turnbuckle to prevent the lifeline from twisting, use a tool to rotate the turnbuckle. Rotate the turnbuckle so that the jaws draw toward each other as shown in Figure 28. Tighten the turnbuckle until the indicator is located in the center green section of the window, as shown in Figure 29.

For system with the Ratchet Strap Tensioner:

Pull as much excess webbing through the disengaged Ratchet Strap Tensioner as possible, then begin to cycle the ratchet mechanism until the indicator is located in the center green section of the window as shown in Figure 29. A minimum of 2 full wraps of webbing must be secured around the tensioner body. Adjust cable lifeline length as needed.

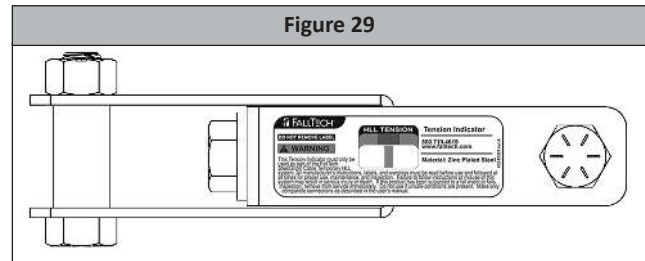
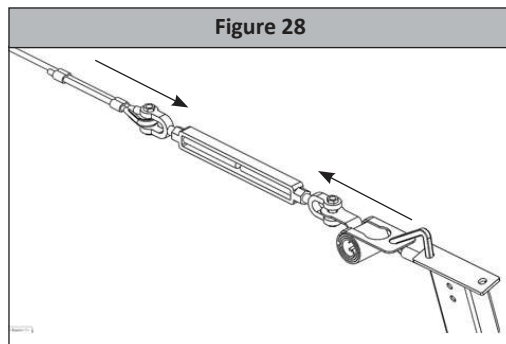

Step 5: Once properly tensioned, the lifeline subsystem can be used.

#### 4.9 Connecting to the HLL System:

Approach the work area using the appropriate access equipment. Connect the PFAS connector (free end connector on the SAL or SRD) directly to the HLL wire rope. Do not connect to any component other than the wire rope. Connectors must meet all compatibility and strength requirements.

#### 4.10 Releasing Lifeline Tension:

Upon completion of work, to move to a new location or to disconnect from the end anchorage connectors, lifeline tension should be released.

For systems with turnbuckle tensioner:

Holding the cable side jaw of the turnbuckle to prevent the lifeline from twisting, use a tool to rotate the turnbuckle. Rotate the turnbuckle so that the jaws draw away each other as shown in Figure 30.

For systems with the Ratchet Strap Tensioner:

Squeeze the release handle as shown in Figure 31.

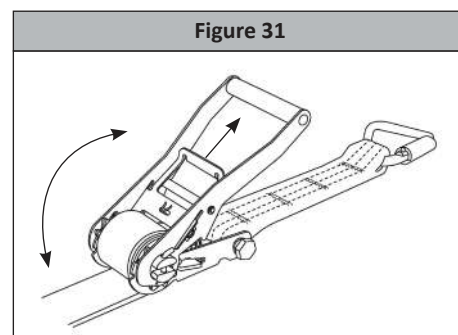
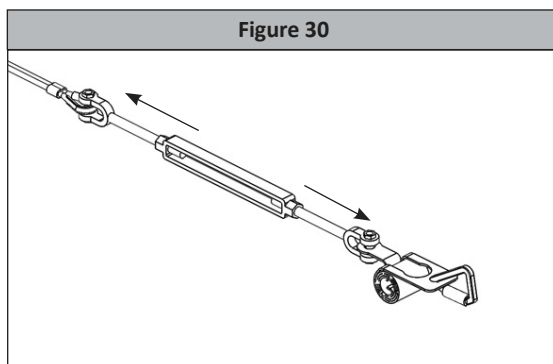

## 5.0 Maintenance, Service and Storage

- Maintenance:** No scheduled maintenance is required, other than the replacement of items that failed inspection.
- Service:** There are no specific service requirements for this system component.
- Storage:** If the unit is removed from its installation location, it should be stored in a dry area free of corrosive elements that may harm or cause the product not to function.

## 6.0 Inspection

- 6.1 Pre-Use Inspection:** Prior to each the HLL system should be inspected by the user for damage, wear and to ensure the lifeline is properly tensioned. Please review the inspection checklist for inspection requirements. Remove from service and replace any component that fails inspection.
- 6.2 Inspection Frequency:** Other than pre-use inspection, the FallTech SteelGrip® Horizontal Lifeline should be inspected by a competent person at least once a year.
- 6.3 Inspection Checklist:** A general inspection should be done at the intervals specified in this manual. Inspect as follows:

Step 1: Inspect labels. Ensure legibility of content. If labels are missing or illegible, remove the system from service.

Step 2: Inspect all metal components for cracks, corrosion, deformities, missing or noticable defects. Metal components include: the FallTech SteelGrip® Coil Energy Absorber, tension indicator, turnbuckle, carabiner, thimble eyes, shackles, and all other hardware.

Step 3: Inspect the entire working length of wire rope for damage caused by chemical corruption or excessive heat as evident by discoloration (A), birdcaging (B), broken wire strands (C), kinks and bent strands (D), see Figure 32.

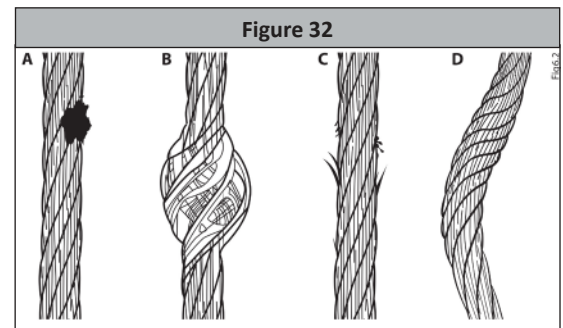

Step 4: Inspect the SteelGrip® Coil Energy Absorber, it should not be extended, cracked or deformed. Figure 33 shows the coil energy absorber in a non-deployed condition whereas Figure 34 shows the coil energy absorber in a partially deployed state. If there is tearing of the metal, remove from service and replace.

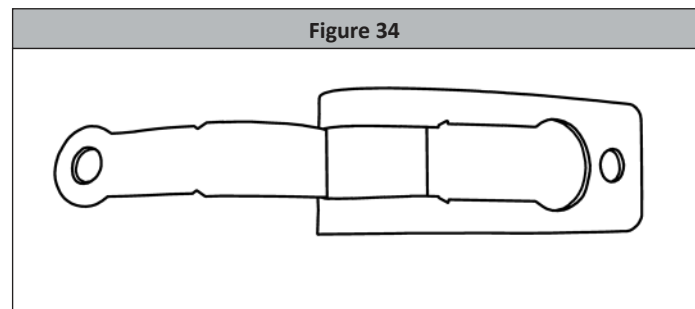
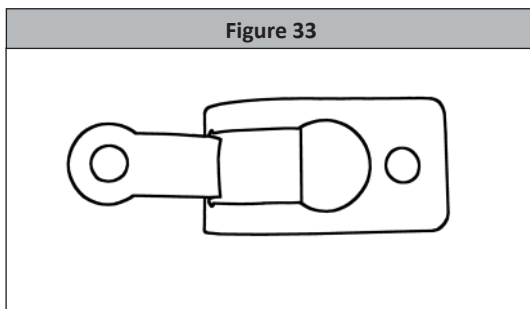

Step 5: Inspect the Ratchet Strap Tensioner webbing for cuts, fraying, and signs of damage from excessive wear or abrasion. Also check for excessive dirt, grease, oil, paint, or other surface contamination or discoloring. Check all stitch locations to ensure that each is intact with no loose, frayed, or torn threads.

**6.4 Inspection Results:** Inspection results should be recorded by a competent person at least once a year.





## 8.0 Definitions

The following are general definitions of fall protection terms as defined by ANSI Z359.0-2012.

**Anchorage** - A secure connecting point or a terminating component of a fall protection system or rescue system capable of safely supporting the impact forces applied by a fall protection system or anchorage subsystem.

**Anchorage Connector** - A component or subsystem that functions as an interface between the anchorage and a fall protection, work positioning, rope access or rescue system for the purpose of coupling the system to the anchorage.

**Arrest Distance** - The total vertical distance required to arrest a fall. The arrest distance includes the deceleration distance and activation distance.

**Authorized Person** - A person assigned by the employer to perform duties at a location where the person will be exposed to a fall hazard.

**Available Clearance** - The distance from a reference point, such as the working platform, to the nearest obstruction that an authorized person might contact during a fall which, if struck, could cause injury.

**Capacity** - The maximum weight that a component, system or subsystem is designed to hold.

**Certification** - The act of attesting in writing that the criteria established by these standards or some other designated standard have been met.

**Certified Anchorage** - An anchorage for fall arrest, positioning, restraint or rescue systems that a qualified person certifies to be capable of supporting the potential fall forces that could be encountered during a fall.

**Clearance** - The distance from a specified reference point, such as the working platform or anchorage of a fall arrest system, to the lower level that a worker might encounter during a fall.

**Clearance Requirement** - The distance below an authorized person that must remain clear of obstructions in order to ensure that the authorized person does not make contact with any objects that would cause injury in the event of a fall.

**Competent Person** - An individual designated by the employer to be responsible for the immediate supervision, implementation and monitoring of the employer's managed fall protection program who, through training and knowledge, is capable of identifying, evaluating and addressing existing and potential fall hazards, and who has the employer's authority to take prompt corrective action with regard to such hazards.

**Component** - An element or integral assembly of interconnected elements intended to perform one function in the system.

**Connecting Subsystem** - An assembly, including the necessary connectors, comprised of all components, subsystems, or both, between the anchorage or anchorage connector and the harness attachment point.

**Connector** - A component or element that is used to couple parts of the system together.

**Deceleration Distance** - The vertical distance between the user's fall arrest attachment at the onset of fall arrest forces during a fall, and after the fall arrest attachment comes to a complete stop.

**Energy (Shock) Absorber** - A component whose primary function is to dissipate energy and limit deceleration forces which the system imposes on the body during fall arrest.

**Fall Arrest** - The action or event of stopping a free fall or the instant where the downward free fall has been stopped.

**Fall Hazard** - Any location where a person is exposed to a potential free fall.

**Free Fall** - The act of falling before a fall protection system begins to apply forces to arrest the fall.

**Free Fall Distance** - The vertical distance traveled during a fall, measured from the onset of a fall from a walking working surface to the point at which the fall protection system begins to arrest the fall.

**Harness, Full Body** - A body support designed to contain the torso and distribute the fall arrest forces over at least the upper thighs, pelvis, chest and shoulders.

**Horizontal Lifeline** - A component of a horizontal lifeline subsystem, consisting of a flexible line with connectors or other coupling means at both ends for securing it horizontally between two anchorages or anchorage connectors.

**Horizontal Lifeline Subsystem** - An assembly, including the necessary connectors, comprised of a horizontal lifeline component and, optionally, of:  
a) An energy absorbing component or, b) A lifeline tensioner component, or both. This subsystem is normally attached at each end to an anchorage or anchorage connector. The end anchorages have the same elevation.

**Horizontal Lifeline** – A component of a horizontal lifeline subsystem, consisting of a flexible line with connectors or other coupling means at both ends for securing it horizontally between two anchorages or anchorage connectors.

**Horizontal Lifeline Subsystem** – An assembly, including the necessary connectors, comprised of a horizontal lifeline component and, optionally, of:  
a) An energy absorbing component or, b) A lifeline tensioner component, or both. This subsystem is normally attached at each end to an anchorage or anchorage connector. The end anchorages have the same elevation.

**Lanyard** - A component consisting of a flexible rope, wire rope or strap, which typically has a connector at each end for connecting to the body support and to a fall arrester, energy absorber, anchorage connector or anchorage.

**Lanyard Connecting Subsystem** - An assembly, including the necessary connectors, comprised of a lanyard only, or a lanyard and energy absorber.

**Personal Fall Arrest System (PFAS)** - An assembly of components and subsystems used to arrest a person in a free fall.

**Positioning** - The act of supporting the body with a positioning system for the purpose of working with hands free.

**Positioning Lanyard** - A lanyard used to transfer forces from a body support to an anchorage or anchorage connector in a positioning system.

**Qualified Person** - A person with a recognized degree or professional certificate and with extensive knowledge, training and experience in the fall protection and rescue field who is capable of designing, analyzing, evaluating and specifying fall protection and rescue systems.

**Self-Retracting Device (SRD)** - A device that contains a drum wound line that automatically locks at the onset of a fall to arrest the user, but that pays out from and automatically retracts onto the drum during normal movement of the person to whom the line is attached.

After onset of a fall, the device automatically locks the drum and arrests the fall. Self-retracting devices include self-retracting lanyards (SRL's), self-retracting lanyards with integral rescue capability (SRL-R's), and self-retracting lanyards with leading edge capability (SRL-LE's) and, hybrid combinations of these.

**Snaphook** - A connector comprised of a hook-shaped body with a normally closed gate or similar arrangement that may be opened to permit the hook to receive an object and, when released, automatically closes to retain the object.

**Swing Fall** - A pendulum-like motion that occurs during and/or after a vertical fall. A swing fall results when an authorized person begins a fall from a position that is located horizontally away from a fixed anchorage.

**Appendix A**

Specifications for FallTech SteelGrip® Temporary Cable HLL				
Model #	Minimum Tensile Strength and Material	Maximum User Capacity	Standards and Regulations	Kit Contents
620020 to 620360	<p><b>5,000 lbs. Minimum Tensile Strength</b></p> <p><b>Cable:</b> 3/8" Diameter 7X19 Galvanized Steel</p> <p><b>SteelGrip® Coil Energy Absorber:</b> Stainless Steel</p> <p><b>Turnbuckle:</b> Drop Forged Galvanized Steel</p> <p><b>Shackles:</b> Drop Forged Galvanized Steel</p> <p><b>Thimbles:</b> Galvanized Steel</p> <p><b>Carabiner:</b> Zinc Plated Forged Alloy Steel</p> <p><b>Cable Clips:</b> Drop Forged Galvanized Steel</p> <p><b>Tension Indicator:</b> Zinc Plated Alloy Steel</p>	<p>Maximum Two Workers at up to 310 lbs. Each</p>	<p>OSHA 1926.502</p>	

Specifications for FallTech SteelGrip® Temporary Cable HLL				
Model #	Minimum Tensile Strength and Material	Maximum User Capacity	Standards and Regulations	Kit Contents
620030R to 620060R 620100R 60230A to 60260A 602100A 62206R	<p><b>5,000 lbs. Minimum Tensile Strength</b></p> <p><b>Cable:</b> 3/8" Diameter 7X19 Galvanized Steel</p> <p><b>SteelGrip® Coil Energy Absorber:</b> Stainless Steel</p> <p><b>Ratchet Strap Tensioner:</b> Forged Alloy Steel and Polyester Webbing</p> <p><b>Shackles:</b> Drop Forged Galvanized Steel</p> <p><b>Thimbles:</b> Galvanized Steel</p> <p><b>Carabiner:</b> Zinc Plated Forged Alloy Steel</p> <p><b>Cable Clips:</b> Drop Forged Galvanized Steel</p> <p><b>Tension Indicator:</b> Zinc Plated Alloy Steel</p>	<p>Maximum Two Workers at up to 310 lbs. Each</p>	<p>OSHA 1926.502</p>	

### List of Components by SteelGrip® Part #

Part #	SteelGrip Coil Energy Absorber	Ferruled Cable	Carabiners	Shackles	Turnbuckle	Ratchet Strap Tensioner	Wire Rope Clips	Thimbles	SteelGrip I-Beam Clamping Stanchion	Web Sling Anchors	Tension Indicator
620020-620060	1	1	2	2	1		2	1			1
620070-620360	2	1	2	3	1		2	1			1
62100A	1		2		1		4	2			
62103D	1			3							
62102C	1			3	1						
62101B	1			1	1		4	2			
60230A-60260A	1	1	2	2	1		2	1		2	1
60280A-602100A	2	1	2	3	1		2	1		2	1
6033012-6036024	1	1	2	2	1		2	1	2		1
6038012-60310024	2	1	2	3	1		2	1	2		1
62201EA	1										
62202S				3							
62203C							4	2			
62204D				2	1						
62205T											1
623020-623360		1									
620030R-620060R	1	1	2	2		1	2	1			
620100R	2	1	2	3		1	2	1			
60230A-60260A	1	1	2	2		1	2	1		2	
602100A	2	1	2	3		1	2	1		2	
62206R						1					
62207C30							30				

FallTech Compatible Anchors	
Item Number	Item Name
603012K	SteelGrip HLL I-Beam Stanchion with 4" to 12" Clamp
603018K	SteelGrip HLL I-Beam Stanchion with 4" to 18" Clamp
603024K	SteelGrip HLL I-Beam Stanchion with 4" to 24" Clamp
7324	2' Pass-Through Sling Anchor
7414	Bolt-on D-ring Anchor
7414P	Weld-on D-ring Anchor
7414SS	Bolt-on D-ring Anchor
7428	6' Cable Pass-Through Sling Anchor, Coated
7432	Dual Truss Roof Anchor
7433	EcoAnchor Water-filled Counterweight
7435	Bolt-on D-Ring Anchor w/integral stud
7435H	Bolt-on D-Ring Anchor
7438	6' Cable Pass-Through Sling Anchor
7440	Removeable Concrete Anchor; 5K
7440S	Removeable Concrete Anchor w/Swivel; 5K
7441	Removeable Concrete Anchor; 10K
7535	12" Stationary Beam Clamp Anchor
7536	24" Stationary Beam Clamp Anchor

Note: The above listing shows the most common FallTech anchors that are compatible with the FallTech SteelGrip® Temporary Cable HLL. Contact FallTech for additional information regarding other anchors not on this list.