

# Confined Space Pole Hoist

## User Instruction Manual

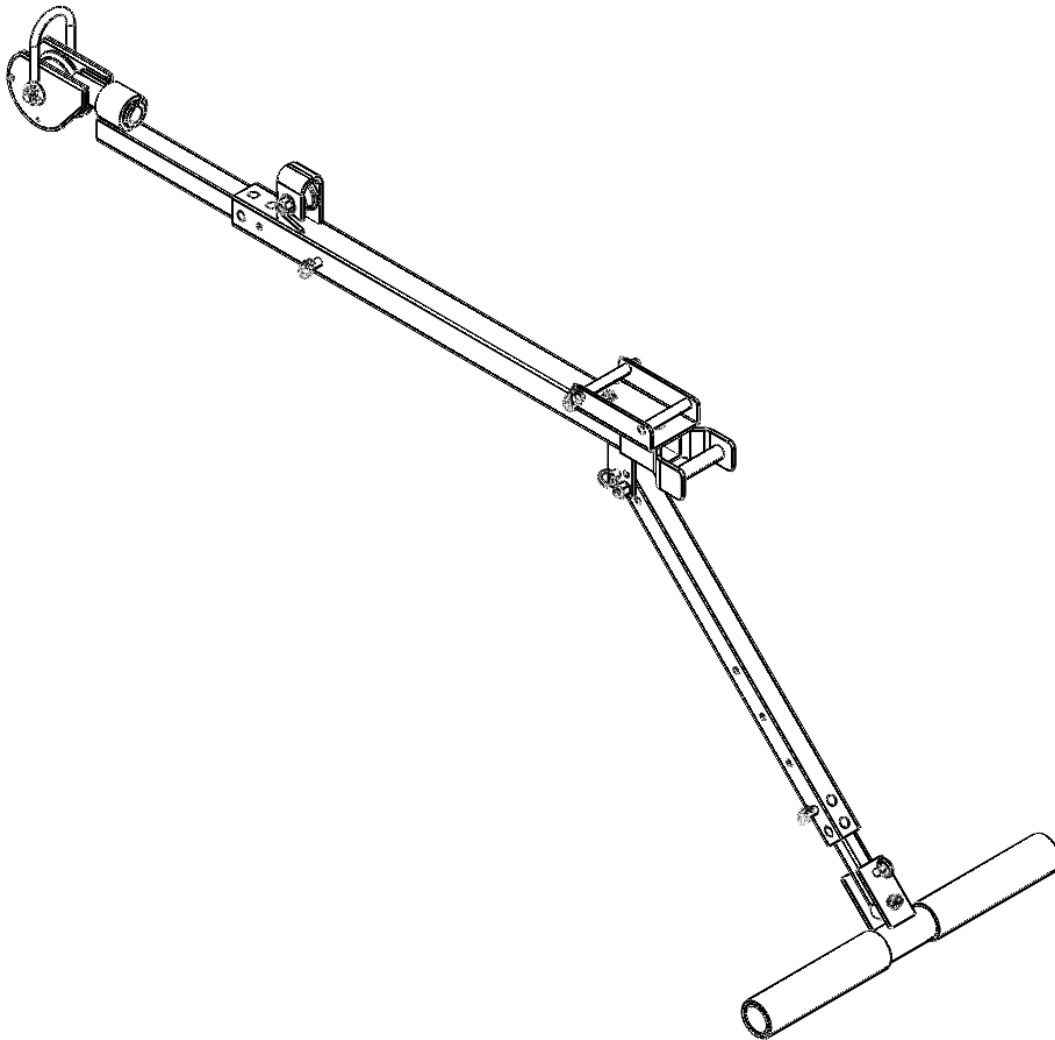

This manual is intended to meet the Manufacturer's Instructions as required by the American National Standards Institute (ANSI) Z359 and Canadian Standards Association (CSA) Z259 and should be used as part of an employee training program as required by the Occupational Safety and Health Administration (OSHA).

# Table of Contents

1.0	Warnings and Important Information .....	3
2.0	Description .....	4
3.0	Application .....	4
4.0	System Requirements .....	4
5.0	Installation and Use .....	5
6.0	Maintenance, Service, and Storage .....	7
.		8
7.0	Inspection .....	9
8.0	Labels .....	10
9.0	Definitions .....	12
	Appendix A .....	

For the purposes of this manual, the FallTech Confined Space Pole Hoist may be referred to as the Confined Space Pole Hoist, Pole Hoist, product, or the system.

Throughout this manual, ANSI Z359.0-2012 fall protection words, phrases, and terms are used. These terms are all formally defined in Section 9.0 of this manual.

## 1.0 Warnings and Important Information

### **WARNING**

- Avoid moving machinery, thermal, electrical, and/or chemical hazards as contact may cause serious injury or death.
- Avoid swing falls.
- Follow the weight restrictions and recommendations in this manual.
- Remove from service any equipment subjected to fall arrest forces.
- Remove from service any equipment that fails inspection.
- Do not alter or intentionally misuse this equipment.
- Consult FallTech when using this equipment in combination with components or subsystems other than those described in this manual.
- Do not connect rebar hooks, large carabiners, or large snap hooks to the FBH dorsal D-rings as this may cause a roll-out condition and/or unintentional disengagement.
- Avoid sharp and/or abrasive surfaces and edges.
- Use caution when performing arc welding. Arc flash from arc welding operations, including accidental arcs from electrical equipment, can damage equipment and are potentially fatal.
- Examine the work area. Be aware of the surroundings and workplace hazards that may impact safety, security, and the functioning of fall arrest systems and components.
- Hazards may include but not be limited to cable or debris tripping hazards, equipment failures, personnel mistakes, moving equipment such as carts, barrows, fork lifts, cranes, or dollies. Do not allow materials, tools or equipment in transit to contact any part of the fall arrest system.
- Do not work under suspended loads.

### **IMPORTANT**

This product is part of a personal fall arrest, restraint, work positioning, suspension, or rescue system. A Personal Fall Arrest System (PFAS) is typically composed of an anchorage and a Full Body Harness (FBH), with a connecting device, i.e., a Shock Absorbing Lanyard (SAL), or a Self-Retracting Device (SRD), attached to the dorsal D-ring of the FBH.

These instructions must be provided to the worker using this equipment. The worker must read and understand the manufacturer's instructions for each component or part of the complete system. Manufacturer's instructions must be followed for proper use, care, and maintenance of this product. These instructions must be retained and be kept available for the worker's reference at all times. Alterations or misuse of this product, or failure to follow instructions, may result in serious injury or death.

A Fall Protection Plan must be on file and available for review by all workers. It is the responsibility of the worker and the purchaser of this equipment to assure that users of this equipment are properly trained in its use, maintenance, and storage. Training must be repeated at regular intervals. Training must not subject the trainee to fall hazards.

Consult a doctor if there is reason to doubt your fitness to safely absorb the shock of a fall event. Age and fitness seriously affect a worker's ability to withstand falls. Pregnant women or minors must not use this equipment.

ANSI limits the weight of fall protection equipment users to a maximum of 310 lbs. Products in this manual may have a rated capacity exceeding ANSI capacity limits. Heavy users experience more risk of serious injury or death due to falls because of increased fall arrest forces placed on the user's body. In addition, the onset of suspension trauma after a fall event may be accelerated for heavy users.

The user of the equipment discussed in this manual must read and understand the entire manual before beginning work.

NOTE: For more information, consult the ANSI Z359 body of standards.

## 2.0 Application

**2.1 Description:** The FallTech Confined Space Pole Hoist, see Figure 1, is designed for use with a suitable anchor point above or beside a confined space entry point, see Figure 2.

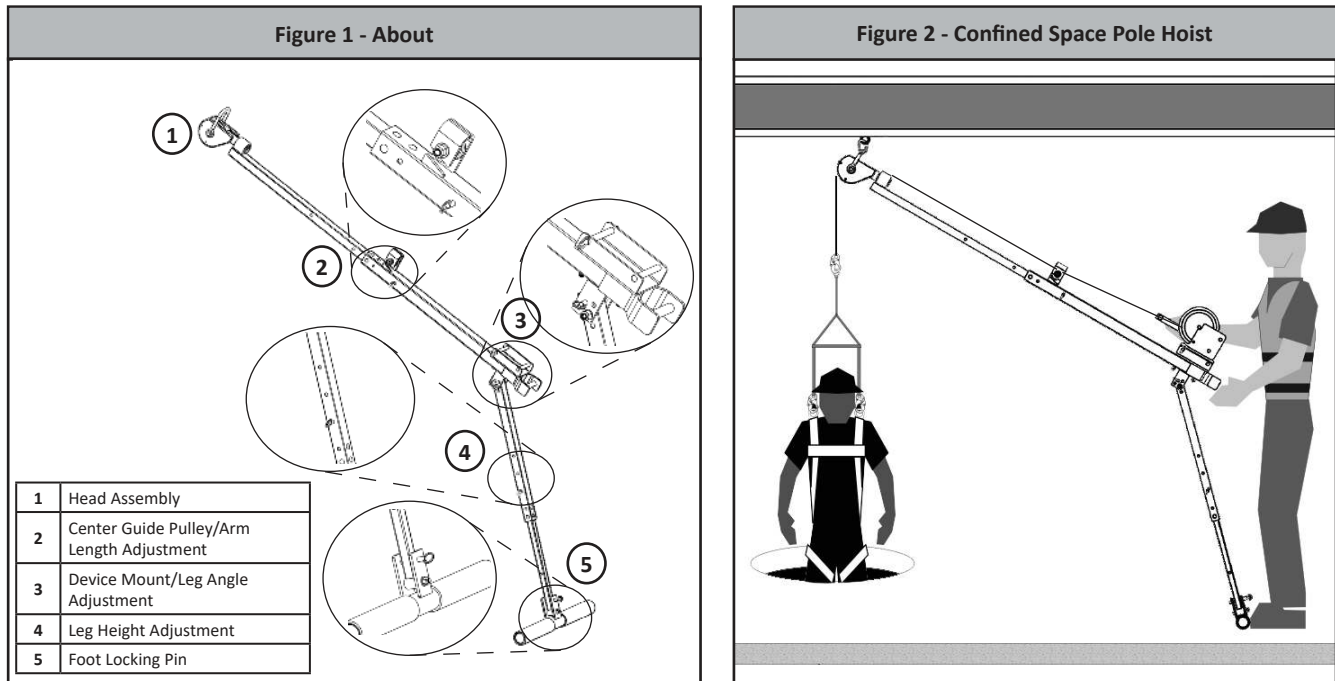

**2.2 Purpose:** The FallTech Confined Space Pole Hoist is designed to work as part of a system to raise or lower a person or material to work in a confined space for entry, retrieval, fall arrest applications, and material handling using a winch or Self Retracting Lifeline - Retrieval (SRL-R). The Pole Hoist is used along with an overhead anchor point for confined space openings such as manholes, sewer openings, and tank hatches.

**2.3 Application Limits:** An anchorage selected for PFAS must have a strength able to sustain a static load applied in the direction permitted by the PFAS of at least:

- Two times the maximum arrest force permitted when certification exists, or
- 5,000 lbs. (22.2 kN) in the absence of certification.

**2.4 System Capacity:** The maximum capacity of the FallTech Confined Space Pole Hoist is one worker for confined space entry and egress, with the worker weighing no more than 310lbs (140kg) including clothing, tools, etc. The maximum capacity of the Confined Space Pole Hoist for material handling is 310lbs.

## 3.0 System Requirements

**3.1 Compatibility of Connectors:** Connectors are considered to be compatible with connecting elements when they have been designed to work together in such a way that their sizes and shapes do not cause their gate mechanisms to inadvertently open regardless of how they become oriented. Contact FallTech if you have any questions about compatibility. Connectors must be compatible with the anchorage or other system components. Do not use equipment that is not compatible. Non-compatible connectors may unintentionally disengage, see Figure 3. Connectors must be compatible in size, shape, and strength. Self-closing, self-locking snap hooks and carabiners are specified by OSHA and ANSI Z359.12.

**3.2 Compatibility of Components:** Equipment is designed for use with approved components and subsystems only. Substitutions or replacements made with non-ANSI Z359 compliant components or subsystems may jeopardize compatibility of equipment and may affect the safety and reliability of the complete system. Ensure compatibility between the connectors if non-FallTech components are used for fall protection.

**3.3 Connectors:** Only use self-locking snap hooks, rebar hooks, and carabiners with this equipment. Only use connectors that are suitable to each application. Ensure all connections are compatible in size, shape, and strength. Do not use equipment that is not compatible. Visually ensure all connectors close and lock completely. Connectors (snap hooks, rebar hooks, and carabiners) are designed for use only as specified in this manual.

Figure 3 - Non-Compatible Connections

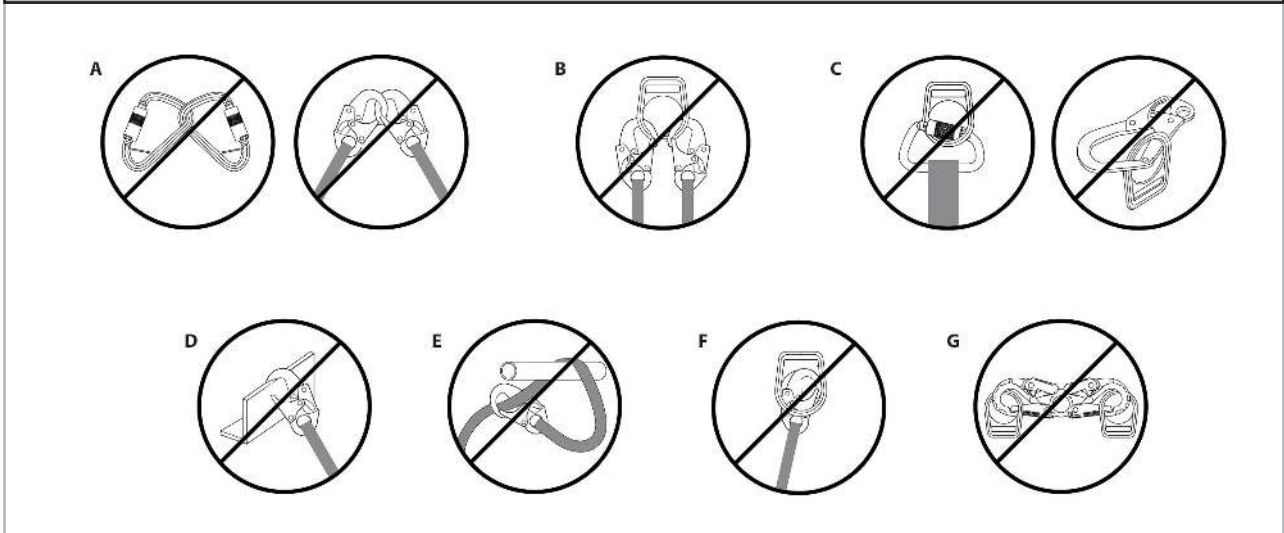

## 4.0 Installation and Use

### 4.1 Setup

4.1.1 Before setting up the FallTech Confined Space Pole Hoist, perform the Pre-Use Inspection as outlined in Section 6.

4.1.2 Remove the detent pin from the foot assembly, see Figure 4. Rotate the foot 90 degrees, place the detent pin to lock it in position, see Figure 5.

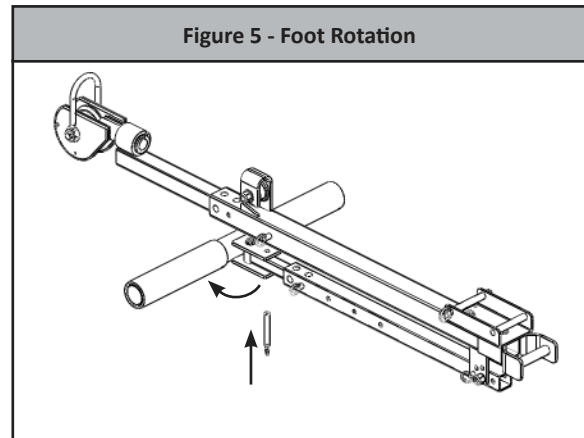
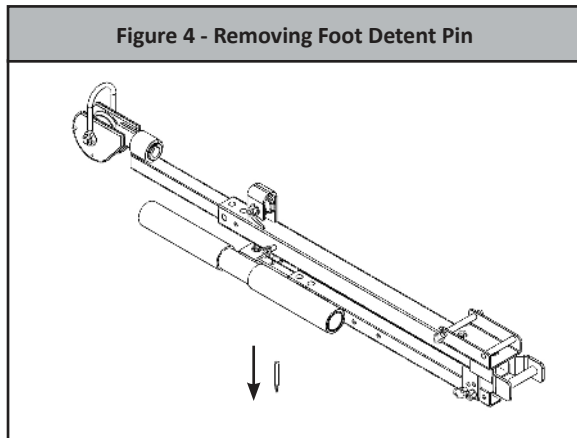

4.1.3 Remove the detent pin from the leg assembly, see Figure 6. Rotate the leg to a vertical angle, place the detent pin to lock it in position, see Figure 7.

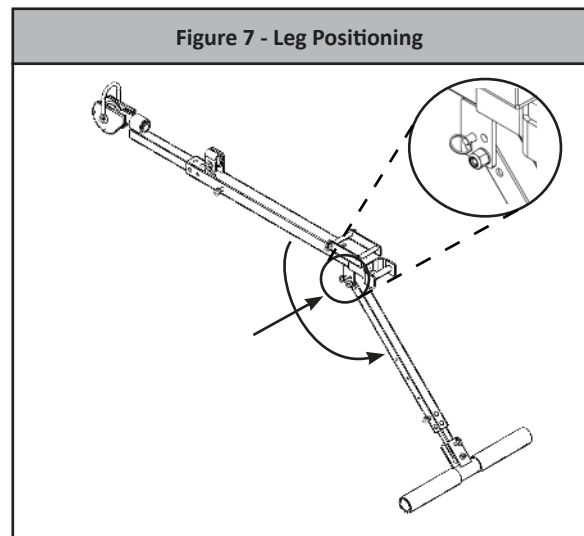
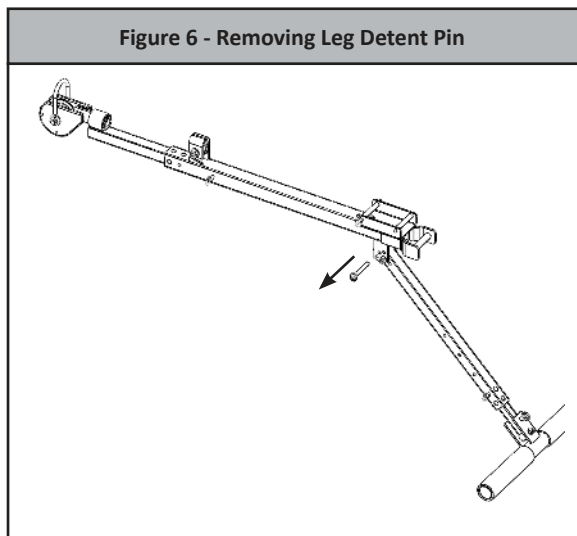

**4.1.4** Remove the Top Arm detent pin to adjust the length of the arm. Based on which detent pin hole is used, there is a 6" adjustment in which the arm can be lengthened.

**4.1.5** Remove the Lower Leg detent pin to adjust the Lower Leg length.

**4.1.6** Remove the detent pin to adjust the angle of the Top Arm to the Lower Leg, see Figure 8. The arm can be adjusted to three different angles: 0, 45, and 90 degrees.

**4.2 Device Installation**

**4.2.1** To attach a winch or SRL-R to the Device Receiver Bracket, place the notch in the device side bracket over the bottom bar of the bracket as shown in Figure 9 and 10. Rotate to align the upper holes on the bracket, see Figure 11 and insert the provided detent pin, see Figure 12.

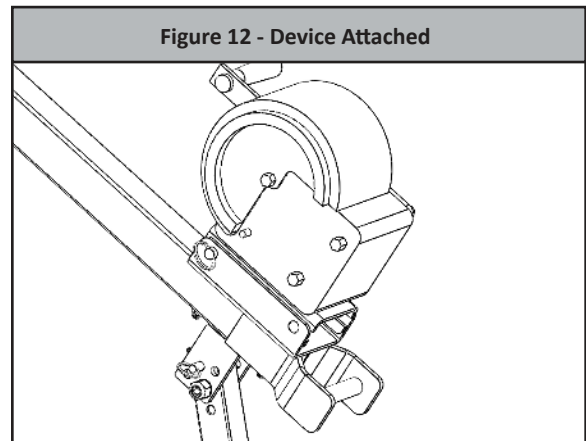
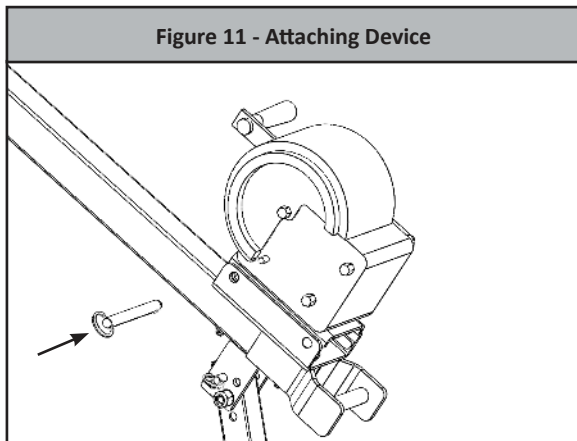
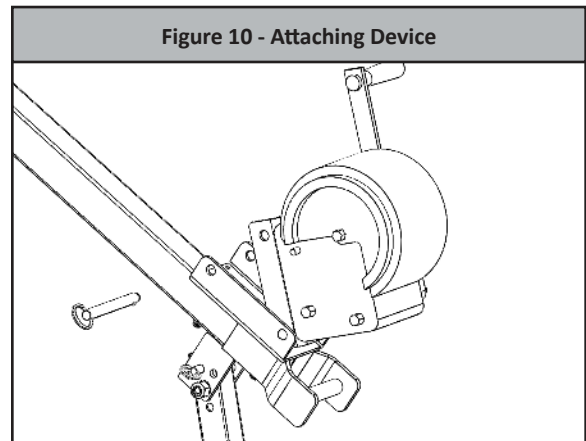
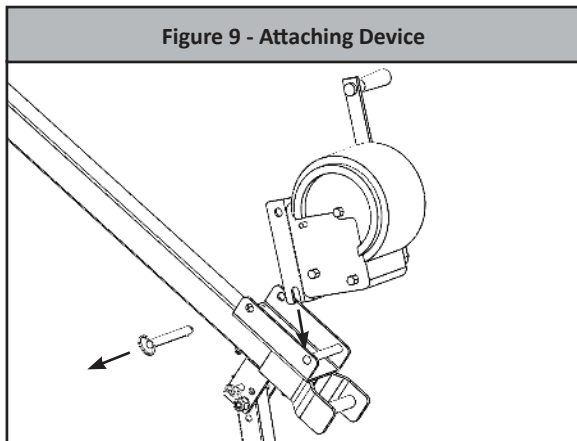
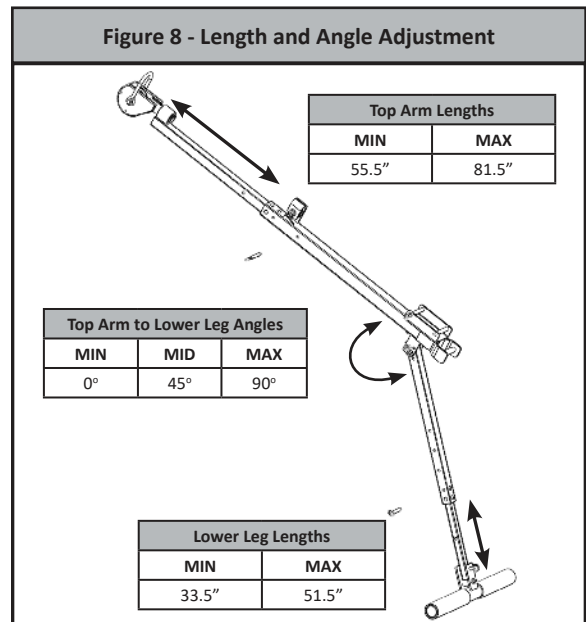

### 4.3 Cable Routing

**4.3.1** Install the Winch or SRL-R as described in Section 4.2. Pay out approximately 6 ft. of cable. Maintain tension on the cable and place the cable into the slot and under the Center Guide Pulley (1). Rotate the Head Assembly (2) to align the slots and place the cable over the Head Pulley (3). Remove and reinstall the detent pin to capture the cable between the detent pin and pulley, see Figure 13.

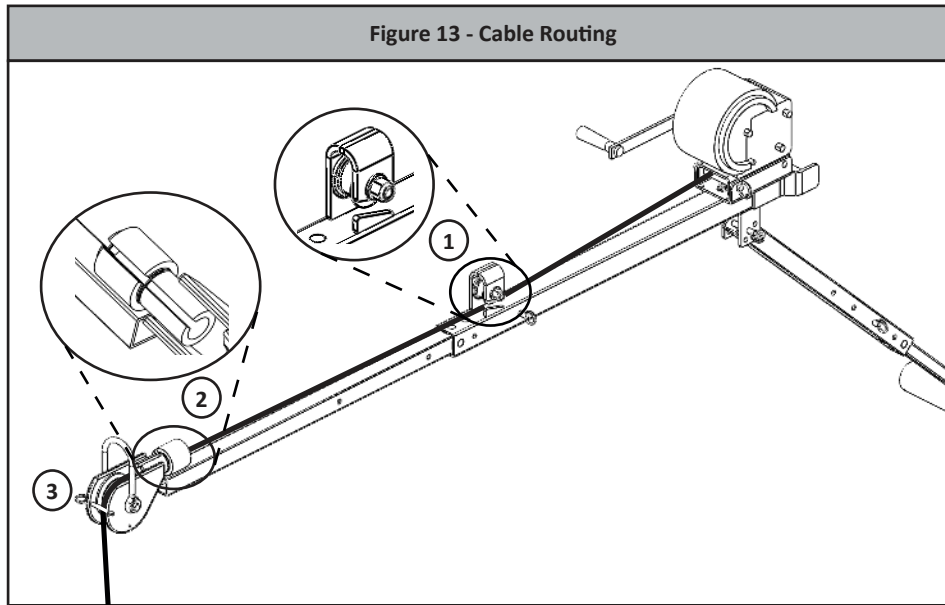

### 4.4 Anchor Point Installation

**4.4.1** Connect the U-Shaped Hanger Bracket to an anchor point, see Section 2.3, with certified hardware, such as a properly rated carabiner, see Figure 14. Adjust the Lower Leg in a vertical position to support the weight of the Pole Hoist and Winch/SRL-R assembly.

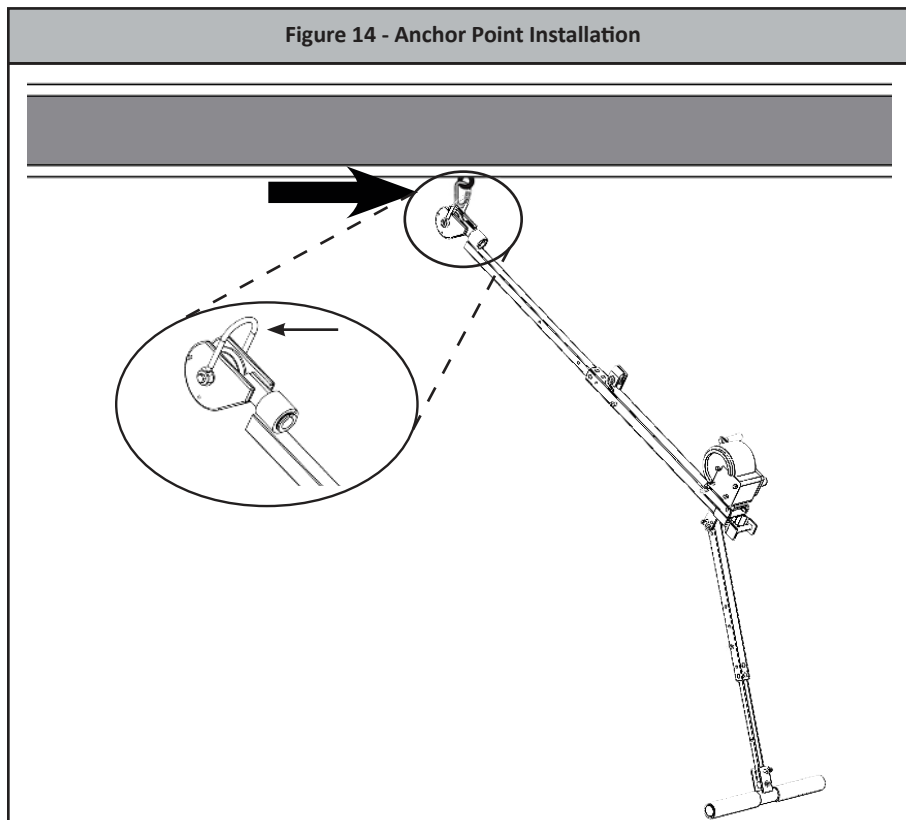





## 9.0 Definitions

The following are general definitions of fall protection terms as defined by ANSI Z359.0-2012.

**Anchorage** - A secure connecting point or a terminating component of a fall protection system or rescue system capable of safely supporting the impact forces applied by a fall protection system or anchorage subsystem.

**Anchorage Connector** - A component or subsystem that functions as an interface between the anchorage and a fall protection, work positioning, rope access or rescue system for the purpose of coupling the system to the anchorage.

**Arrest Distance** - The total vertical distance required to arrest a fall. The arrest distance includes the deceleration distance and activation distance.

**Authorized Person** - A person assigned by the employer to perform duties at a location where the person will be exposed to a fall hazard.

**Available Clearance** - The distance from a reference point, such as the working platform, to the nearest obstruction that an authorized person might contact during a fall which, if struck, could cause injury.

**Capacity** - The maximum weight that a component, system or subsystem is designed to hold.

**Certification** - The act of attesting in writing that the criteria established by these standards or some other designated standard have been met.

**Certified Anchorage** - An anchorage for fall arrest, positioning, restraint or rescue systems that a qualified person certifies to be capable of supporting the potential fall forces that could be encountered during a fall.

**Clearance** - The distance from a specified reference point, such as the working platform or anchorage of a fall arrest system, to the lower level that a worker might encounter during a fall.

**Clearance Requirement** - The distance below an authorized person that must remain clear of obstructions in order to ensure that the authorized person does not make contact with any objects that would cause injury in the event of a fall.

**Competent Person** - An individual designated by the employer to be responsible for the immediate supervision, implementation and monitoring of the employer's managed fall protection program who, through training and knowledge, is capable of identifying, evaluating and addressing existing and potential fall hazards, and who has the employer's authority to take prompt corrective action with regard to such hazards.

**Component** - An element or integral assembly of interconnected elements intended to perform one function in the system.

**Connecting Subsystem** - An assembly, including the necessary connectors, comprised of all components, subsystems, or both, between the anchorage or anchorage connector and the harness attachment point.

**Connector** - A component or element that is used to couple parts of the system together.

**Deceleration Distance** - The vertical distance between the user's fall arrest attachment at the onset of fall arrest forces during a fall, and after the fall arrest attachment comes to a complete stop.

**Energy (Shock) Absorber** - A component whose primary function is to dissipate energy and limit deceleration forces which the system imposes on the body during fall arrest.

**Fall Arrest** - The action or event of stopping a free fall or the instant where the downward free fall has been stopped.

**Fall Hazard** - Any location where a person is exposed to a potential free fall.

**Free Fall** - The act of falling before a fall protection system begins to apply forces to arrest the fall.

**Free Fall Distance** - The vertical distance traveled during a fall, measured from the onset of a fall from a walking working surface to the point at which the fall protection system begins to arrest the fall.

**Harness, Full Body** - A body support designed to contain the torso and distribute the fall arrest forces over at least the upper thighs, pelvis, chest and shoulders.

**Horizontal Lifeline** - A component of a horizontal lifeline subsystem, consisting of a flexible line with connectors or other coupling means at both ends for securing it horizontally between two anchorages or anchorage connectors.

**Horizontal Lifeline Subsystem** - An assembly, including the necessary connectors, comprised of a horizontal lifeline component and, optionally, of:  
a) An energy absorbing component or, b) A lifeline tensioner component, or both. This subsystem is normally attached at each end to an anchorage or anchorage connector. The end anchorages have the same elevation.

**Horizontal Lifeline** – A component of a horizontal lifeline subsystem, consisting of a flexible line with connectors or other coupling means at both ends for securing it horizontally between two anchorages or anchorage connectors.

**Horizontal Lifeline Subsystem** – An assembly, including the necessary connectors, comprised of a horizontal lifeline component and, optionally, of:  
a) An energy absorbing component or, b) A lifeline tensioner component, or both. This subsystem is normally attached at each end to an anchorage or anchorage connector. The end anchorages have the same elevation.

**Lanyard** - A component consisting of a flexible rope, wire rope or strap, which typically has a connector at each end for connecting to the body support and to a fall arrester, energy absorber, anchorage connector or anchorage.

**Lanyard Connecting Subsystem** - An assembly, including the necessary connectors, comprised of a lanyard only, or a lanyard and energy absorber.

**Personal Fall Arrest System (PFAS)** - An assembly of components and subsystems used to arrest a person in a free fall.

**Positioning** - The act of supporting the body with a positioning system for the purpose of working with hands free.

**Positioning Lanyard** - A lanyard used to transfer forces from a body support to an anchorage or anchorage connector in a positioning system.

**Qualified Person** - A person with a recognized degree or professional certificate and with extensive knowledge, training and experience in the fall protection and rescue field who is capable of designing, analyzing, evaluating and specifying fall protection and rescue systems.

**Self-Retracting Device (SRD)** - A device that contains a drum wound line that automatically locks at the onset of a fall to arrest the user, but that pays out from and automatically retracts onto the drum during normal movement of the person to whom the line is attached.

**Snaphook** - A connector comprised of a hook-shaped body with a normally closed gate or similar arrangement that may be opened to permit the hook to receive an object and, when released, automatically closes to retain the object.

**Swing Fall** - A pendulum-like motion that occurs during and/or after a vertical fall. A swing fall results when an authorized person begins a fall from a position that is located horizontally away from a fixed anchorage.

The following are general definitions of fall protection terms as defined by OSHA 1910.146.

**Confined Space - OSHA defines a Confined Space as:**

- Is large enough for an employee to enter fully and perform assigned work;
- Is not designed for continuous occupancy by the employee; and
- Has a limited or restricted means of entry or exit.

These spaces may include underground vaults, tanks, storage bins, pits and diked areas, vessels, silos and other similar areas.

**Permit Required Confined Space has one or more of these characteristics:**

- Contains or has the potential to contain a hazardous atmosphere;
- Contains a material with the potential to engulf someone who enters the space;
- Has an internal configuration that might cause an entrant to be trapped or asphyxiated by inwardly converging walls or by a floor that slopes downward and tapers to a smaller cross section; and/or
- Contains any other recognized serious safety or health hazards.

## APPENDIX A

<b>Table 1: Specifications for Confined Space Pole Hoist</b>				
<b>Part Numbers</b>	<b>Minimum Tensile Strength and Material</b>	<b>Maximum User Capacity</b>	<b>Standards &amp; Regulations</b>	<b>Image</b>
<p>605047</p> <p>Confined Space Pole Hoist</p>	<p>6061-T6 Aluminum Zinc Plated Steel</p>	<p>Maximum One Worker up to 310 lbs. for Normal Confined Space Entry/Egress Operations</p>	<p>OSHA 1926.502</p>	