

# Ladder Stanchion Anchors

## User Instruction Manual

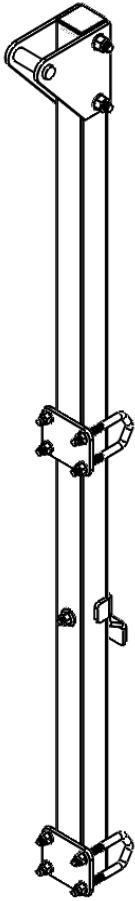

6160505

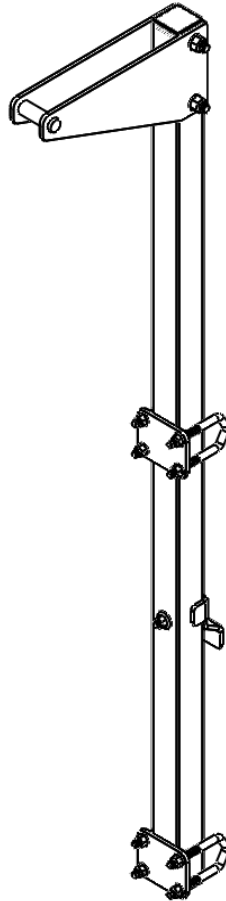

6160512



6161012

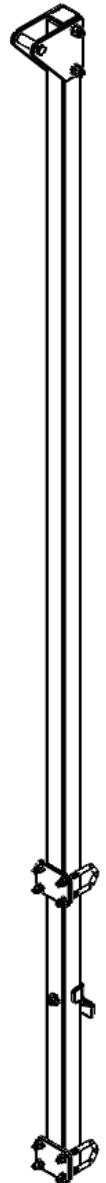

6161005

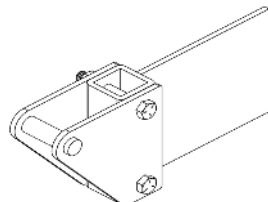

6160512W

This manual should be used as part of an employee training program as required by the Occupational Safety and Health Administration (OSHA).

## Table of Contents

1.0	Warnings and Important Information .....	3
2.0	Definition.....	4
3.0	Application .....	4
4.0	System Requirements .....	4
5.0	Assembly, Installation, and Use .....	5
6.0	Maintenance and Service .....	9
7.0	Inspection .....	9
8.0	Labels .....	11
9.0	Definitions .....	12
	Appendix A .....	14

For purposes of this manual, the FallTech Ladder Stanchion Anchor in all iterations may be referred to as the Ladder Stanchion Anchor, Ladder Stanchion, the anchor, the anchorage connector, the equipment, the product, or the unit.

Throughout this manual, ANSI Z359.0-2012 fall protection words, phrases and terms are used. These terms are all formally defined in Section 8 of this manual.

## 1.0 Warnings and Important Information

### **WARNING**

- Avoid moving machinery, thermal, electrical and/or chemical hazards as contact may cause serious injury or death.
- Avoid swing falls.
- Follow the weight restrictions and recommendations in this manual.
- Remove from service any equipment subjected to fall arrest forces.
- Remove from service any equipment that fails inspection.
- Do not alter or intentionally misuse this equipment.
- Consult FallTech when using this equipment in combination with components or subsystems other than those described in this manual.
- Do not connect rebar hooks, large carabiners, or large snap hooks to the FBH dorsal D-rings as this may cause a roll-out condition and/or unintentional disengagement.
- Avoid sharp and/or abrasive surfaces and edges.
- Use caution when performing arc welding. Arc flash from arc welding operations, including accidental arcs from electrical equipment, can damage equipment and are potentially fatal.
- Examine the work area. Be aware of the surroundings and workplace hazards that may impact safety, security, and the functioning of fall arrest systems and components.
- Hazards may include but not be limited to cable or debris tripping hazards, equipment failures, personnel mistakes, moving equipment such as carts, barrows, fork lifts, cranes, or dollies. Do not allow materials, tools or equipment in transit to contact any part of the fall arrest system.
- Do not work under suspended loads.

### **IMPORTANT**

This product is part of a personal fall arrest, restraint, work positioning, suspension, or rescue system. A Personal Fall Arrest System (PFAS) is typically composed of an anchorage and a Full Body Harness (FBH), with a connecting device, i.e., a Shock Absorbing Lanyard (SAL), or a Self-Retracting Device (SRL), attached to the dorsal D-ring of the FBH.

These instructions must be provided to the worker using this equipment. The worker must read and understand the manufacturer's instructions for each component or part of the complete system. Manufacturer's instructions must be followed for proper use, care, and maintenance of this product. These instructions must be retained and be kept available for the worker's reference at all times. Alterations or misuse of this product, or failure to follow instructions, may result in serious injury or death.

A Fall Protection Plan must be on file and available for review by all workers. It is the responsibility of the worker and the purchaser of this equipment to assure that users of this equipment are properly trained in its use, maintenance, and storage. Training must be repeated at regular intervals. Training must not subject the trainee to fall hazards.

Consult a doctor if there is reason to doubt your fitness to safely absorb the shock of a fall event. Age and fitness seriously affect a worker's ability to withstand falls. Pregnant women or minors must not use this equipment.

ANSI limits the weight of fall protection equipment users to a maximum of 310 lbs. Products in this manual may have a rated capacity exceeding ANSI capacity limits. Heavy users experience more risk of serious injury or death due to falls because of increased fall arrest forces placed on the user's body. In addition, the onset of suspension trauma after a fall event may be accelerated for heavy users.

The user of the equipment discussed in this manual must read and understand the entire manual before beginning work.

NOTE: For more information consult the ANSI Z359 body of standards.

## 2.0 Description

The FallTech® Ladder Stanchion Anchor is an OSHA compliant anchorage connector for a single personal fall arrest system (PFAS) utilizing a overhead self-retracting lifeline (SRL). The Ladder Stanchion Anchor is a galvanized steel post with mounting hardware to secure to various types and sizes of fixed ladders. Two different lengths provide overhead access for ladders that both lead up to the working platform or extend past the working platform. There is also a weld-on version for applications where an existing structure above the ladder can serve as the anchor point for the self-retracting lifeline. See Tables 1 and 2 in Appendix A for specifications on the different versions of the Ladder Stanchion Anchor.

### WARNING

Be sure to read, understand, and follow all instructions and warnings in this manual.  
Any misuse could result in serious injury or death.

## 3.0 Application

**3.1 Purpose:** The FallTech Ladder Stanchion Anchor is designed to work as part of an overhead anchorage system with a self-retracting lifeline (SRL) to provide fall arrest for one worker when climbing vertically.

**3.2 Personal Fall Arrest System:** A PFAS is typically composed of an anchorage and a Full Body Harness (FBH), with an energy absorbing connecting device, i.e., a EAL, an SRD, or a Fall Arrester Connecting Subsystem (FACSS), attached to the dorsal D-ring of a properly fitted and adjusted FBH. All uses and applications of a FBH with this equipment requires the FBH to be properly fitted and adjusted to the user. Failure to properly fit the FBH to the user could result in serious injury or death.

**3.3 Application Limits:** The Ladder Stanchion Anchor is intended to be used only as an overhead anchor point. Care should be taken to understand the capacity of the system, anchorage strength requirements, total allowable free fall, and the requirements of how the user's PFAS deploys during a fall event.

**3.4 Approved Applications:** Below are applications for which all FallTech® Ladder Stanchion Anchor is specifically suited. This list is not all-inclusive, but is intended to anticipate the most common applications in which this product may be used.

**3.4.1 Personal Fall Arrest:** The FallTech® Ladder Stanchion Anchor used as the anchorage component of a PFAS to protect the user in the event of a fall. PFAS must use a self-retracting lifeline that limits the maximum arrest force to 1,800 lbs. per applicable OSHA regulations.

## 4.0 System Requirements

**4.1 System Capacity:** The maximum capacity of the FallTech Ladder Stanchion Anchor is one worker weighing 425 lbs including tools, clothing, etc. For workers weighing 310-425 lbs, a properly rated SRL must be used.

**4.2 Bolt-On Ladder Stanchion Anchor Connection Requirements:** The unit must be attached to a minimum of three, 1/2" to 1-1/4" diameter, rungs of a fixed ladder with a rung spacing of 12" +/- 2". Each rung must have Minimum Ultimate Strength of 1,200 lbs. The permanent structure the fixed ladder is attached to and the connections between the fixed ladder and structure must be able to withstand a load of 3,600 lbs in both the downward and outward directions. The ladder must not be mounted with a pitch greater than 90 degrees from horizontal, i.e., a ladder with an outward pitch is not permissible. When installing the unit in a transition area from ladder to platform, roof top, etc., it is necessary for the ladder stanchion to extend above the platform high enough for the snap hook of the SRL to be 5' above the platform. This is to ensure overhead tie-off is maintained when standing on the platform.

**4.3 Weld-On Ladder Stanchion Anchor Connection Requirements:** The unit must be attached to a permanent structure which can withstand a load of 3,600 lbs in both the downward and outward directions. The Weld-On Ladder Stanchion Anchor must be level within 1 degree of horizontal. The anchor must be installed with sufficient height to ensure overhead SRL anchorage is maintained during use.







**4.4 Rung Reinforcement:** Rung reinforcement bars have a Minimum Ultimate Strength of 1,200 lbs and are an optional accessory used to prevent crushing of hollow rungs and/or to reinforce hollow rungs that do not have an Ultimate Strength of 1,200 lbs. Rung reinforcement bars can be used on fixed ladders with a maximum inside width of 20", measured from the inside of each side rail. Each rung reinforcement bar consists of a 3/4" diameter x 24" threaded rod and accompanying hardware. A qualified person must verify the structure, ladder, and reinforced rungs meet all requirements detailed in this manual before installation of any FallTech Ladder Stanchion Anchor.

**4.5 Compatibility of Connectors:** Connectors are considered to be compatible with connecting elements when they have been designed to work together in such a way that their sizes and shapes do not cause their gate mechanisms to inadvertently open regardless of how they become oriented. Contact FallTech if you have any questions about compatibility. Connectors must be compatible with the anchorage or other system components. Do not use equipment that is not compatible. Non-compatible connectors may unintentionally disengage, see Figure 1. Connectors must be compatible in size, shape, and strength. Self-closing, self-locking snap hooks and carabiners are specified by OSHA and ANSI Z359.12.

**4.6 Compatibility of Components:** Equipment is designed for use with approved components and subsystems only. Substitutions or replacements made with non-ANSI Z359 compliant components or subsystems may jeopardize compatibility of equipment and may affect the safety and reliability of the complete system. Ensure compatibility between the connectors if non-FallTech components are used for fall protection.

**4.7 Connectors:** Only use self-locking snap hooks and carabiners with this equipment. Only use connectors that are suitable to each application. Ensure all connections are compatible in size, shape, and strength. Do not use equipment that is not compatible. Visually ensure all connectors close and lock completely. Connectors (snap hooks and carabiners) are designed for use only as specified in this manual.

Figure 1 - Non-Compatible Connections

  	<p><b>A</b> Never connect two active components (snap hooks or carabiners) to each other.</p>
   	<p><b>B</b> Never connect two active components (snap hooks or carabiners) to a single D-ring at the same time.</p>
	<p><b>C</b> Never connect in a way that would produce a condition of loading on the gate.</p>
	<p><b>D</b> Never attach to a object in a manner whereby the gate (of the snap hook or carabiner) would be prevented from fully closing and locking. Always guard against false connections by visually inspecting for closure and lock.</p>
	<p><b>E</b> Never attach explicitly to a constituent subcomponent (webbing, cable or rope) unless specifically provided for by the manufacturer's instructions for both subcomponents (snap hook or carabiner and webbing, cable or rope).</p>
	<p><b>F</b> Never attach in a manner where an element of the connector (gate or release lever) may become caught on the anchor thereby producing additional risk of false engagement.</p>
	<p><b>G</b> Never attach a spreader snap hook to two side/positioning D-rings in a manner whereby the D-rings will engage the gates; the gates on a spreader must always be facing away from the D-rings during work positioning.</p>

## 5.0 Assembly, Installation, and Use

### 5.1 Bolt-On Ladder Stanchion Anchor Assembly

5.1.1 Large offset Ladder Stanchions, 6160512 and 6161012, require assembly upon arrival before installation. The top bracket must be rotated to the upright position and secured with the included 1/2" diameter bolt, lock washer, and nut; see Figures 2 and 3. Torque both 1/2" diameter bolts to 57 ft-lbs.

Figure 2 - Large Offset Bolt-On Stanchion As Shipped

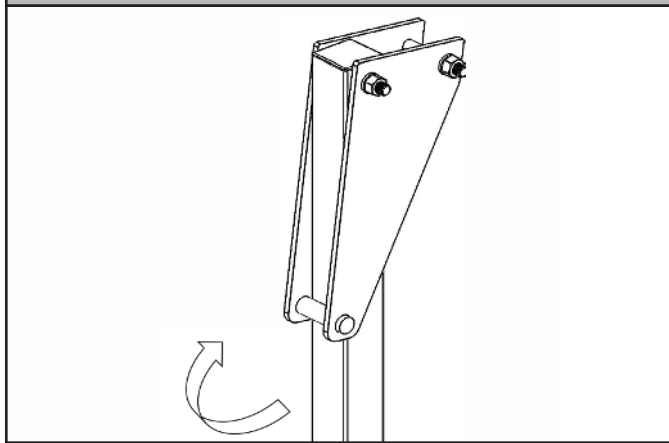
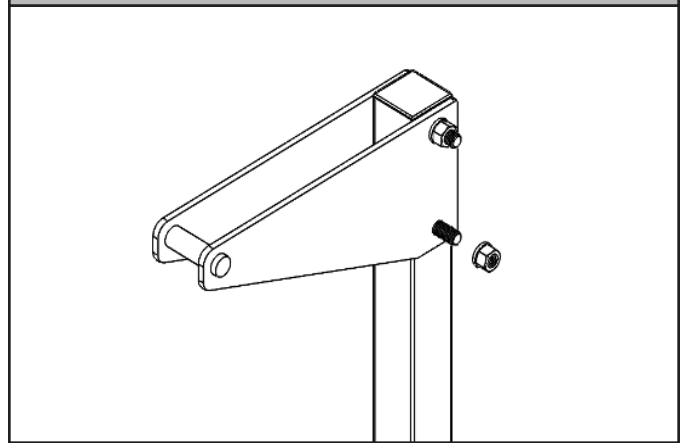

Figure 3- Large Offset Bolt-On Stanchion Assembled



### WARNING

Do not alter or intentionally misuse this equipment. Consult FallTech® when using this equipment in combination with components or subsystems other than those described in this manual. Installation of the Cable Anchor must be done under the supervision of a Competent Person trained in its design and use.

## 5.2 Bolt-On Ladder Stanchion Anchor Installation

Before installation, ensure fixed ladder meets minimum strength requirements of 1,200 lbs Minimum Ultimate Strength per rung, rungs are 1/2" to 1-1/4" diameter, and have a spacing of 12" +/- 2". Ensure structure and fixed ladder connections to the structure can withstand a load of 3,600 lbs in both the downward and outward directions. All installations must be approved to local standards by a Qualified Person. Refer to Section 7.0 for inspection requirements to be completed before the use of this product.

5.2.1 Determine desired mounting location. The Bolt-On Ladder Stanchion Anchor is capable of being mounted in the center of (3) rungs to optimize climbing comfort or offset to either side of the ladder to enable the user to transition onto a platform, rooftop, etc., and can be mounted to the front or rear of the ladder rungs depending on allowable clearance; see Figures 4-7. Ensure Ladder Stanchion is mounted high enough to maintain overhead SRL anchorage.

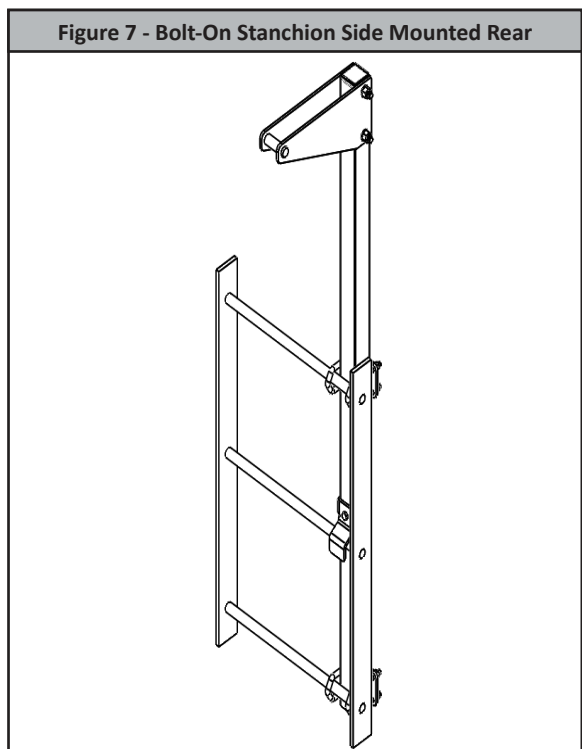
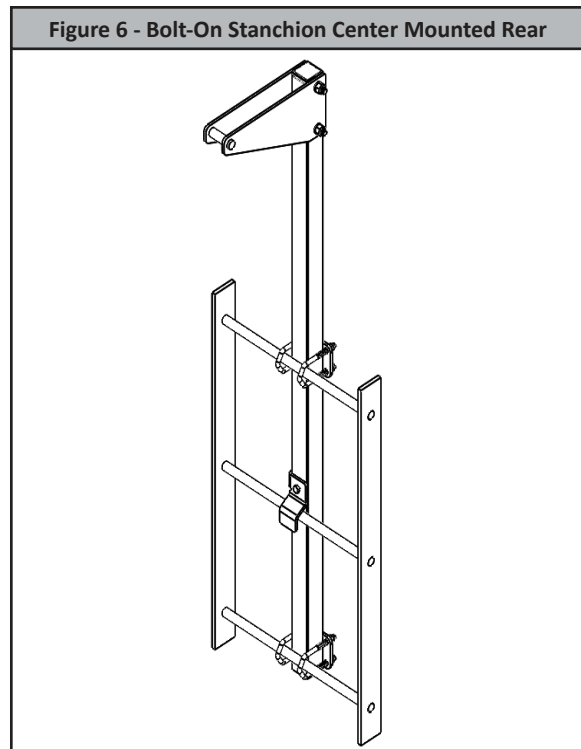
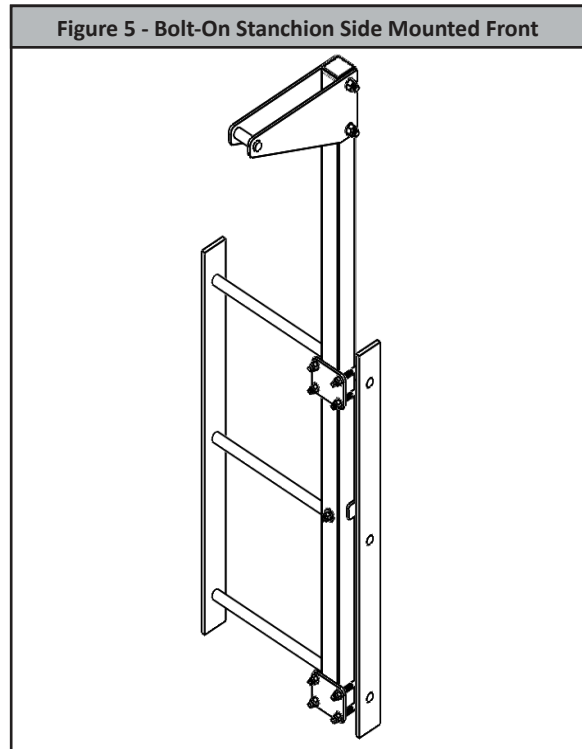
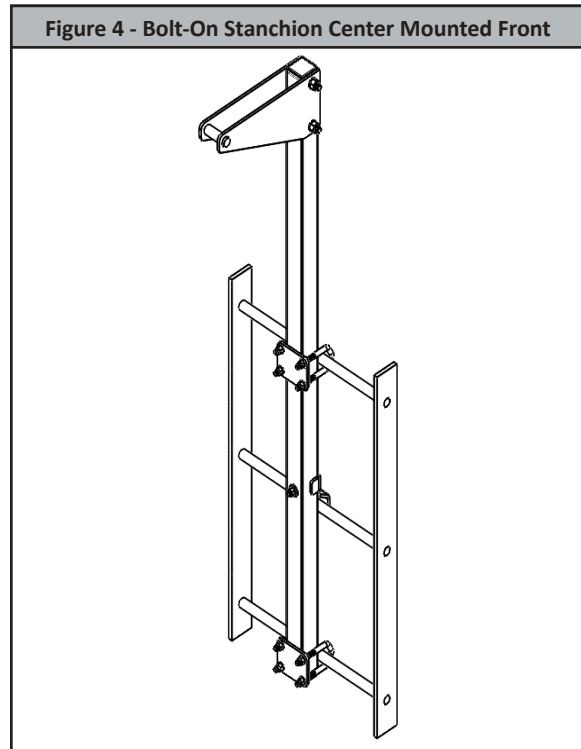

**5.2.2** If installing the Ladder Stanchion Anchor to the rear of the ladder rungs, it is necessary to reinstall the Bent Center Mount in the required orientation with the included 3/8" diameter bolt, washer, lock washer, and nut; torque to 15 ft-lbs; see Figure 8.

**5.2.3** Place the Anchor onto the fixed ladder using the Bent Center Mount to hold the stanchion in place; see Figure 9.

**5.2.4** Connect top mount bracket to uppermost of the (3) rungs using (2) V-bolts with nuts, lock washers, and mounting plate. Ensure Ladder Stanchion Anchor is positioned in desired location on rungs and is fully upright. Tighten V-Bolts so ladder stanchion is stable, but do not fully torque bolts until all mounts are attached; see Figure 10.

**5.2.5** Connect bottom mount bracket to lowermost of the (3) rungs using (2) V-bolts with nuts, lock washers, and mounting plate. Tighten V-Bolts so ladder stanchion is stable, but do not fully torque bolts; see Figure 11.

**5.2.6** Ensure Bolt-On Ladder Stanchion Anchor is fully upright and in desired location. Torque all V-Bolts to 12-17 ft-lbs in the order they were installed. When torquing V-Bolts, it is necessary to alternate the tightening of the nuts in small increments to ensure the V-Bolt is evenly tightened.

**5.2.7** Install compatible FallTech SRL to attachment point using approved loading carabiner. Connect tagline to SRL.

**Figure 8 - Bolt-On Stanchion Installation: Step 1**

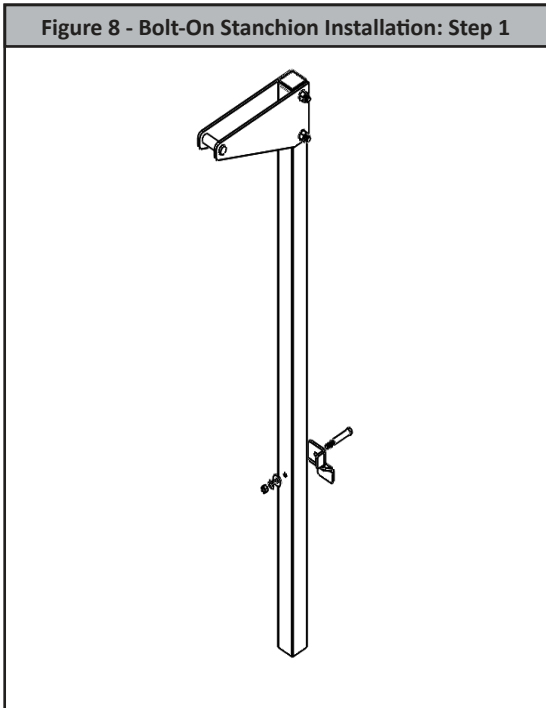

**Figure 9 - Bolt-On Stanchion Installation: Step 2**

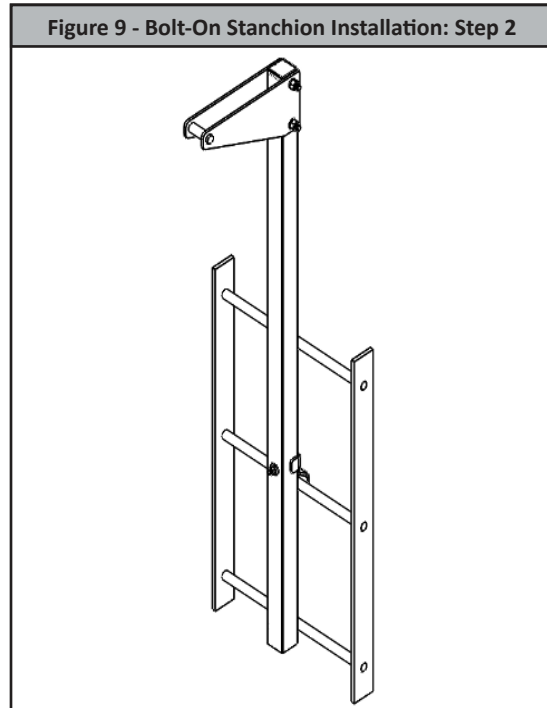

**Figure 10 - Bolt-On Stanchion Installation: Step 3**

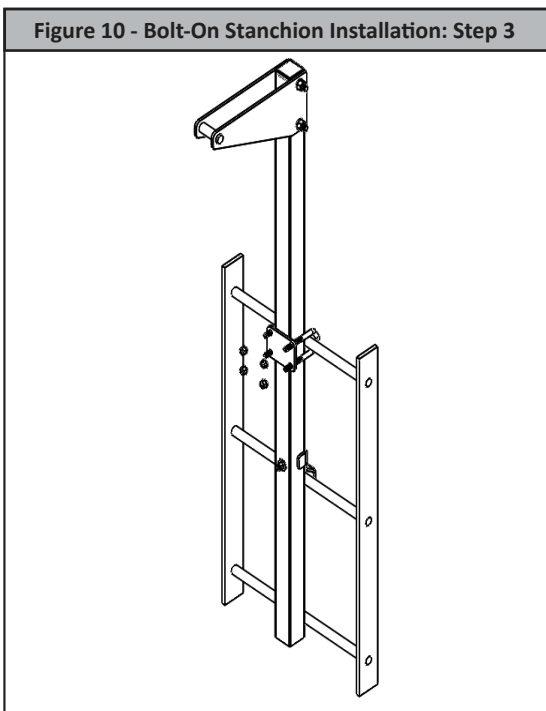

**Figure 11 - Bolt-On Stanchion Installation: Step 4**

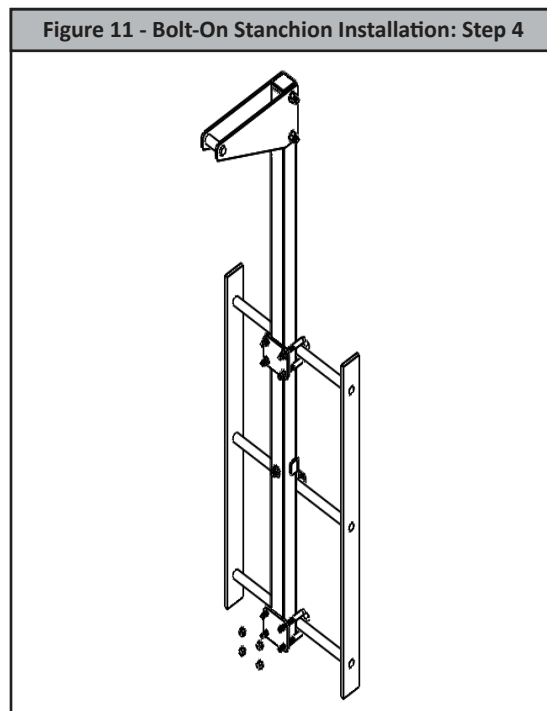

### 5.3 Weld-On Ladder Stanchion Anchor Installation

Before installation, ensure mounting structure meets minimum strength requirements of 3,600 lbs in the downward and outward directions. All installations must be approved to local standards by a Qualified Person. All welding must be completed by a certified welder following local standards. Refer to Section 7.0 for inspection requirements to be completed before the use of this product.

**5.3.1** Determine proper mounting location for Weld-On Ladder Stanchion Anchor. Mounting location must meet strength requirements and ensure overhead SRL anchorage is maintained during entire climb and possible transition to platform, rooftop, etc. Clean and prep Weld-On Anchor bracket and structure for welding. Fillet weld both sides of bracket, 5-1/2" each, with 1/4" radius; see Figure 12. Must be completed by an AWS certified welder and follow all local guidelines.

Note: Mounting bracket must be level within 1 degree; see Figure 13. It is possible to modify the rear portion of the bracket plate in order to attach to a specific structure shape. All welding on modified brackets must meet weld specifications in this section.

**5.3.2** Apply adequate corrosion protection to welded and exposed metal meeting local standards.

**5.3.3** Install compatible FallTech SRL to attachment point using approved carabiner. Connect tagline to SRL.

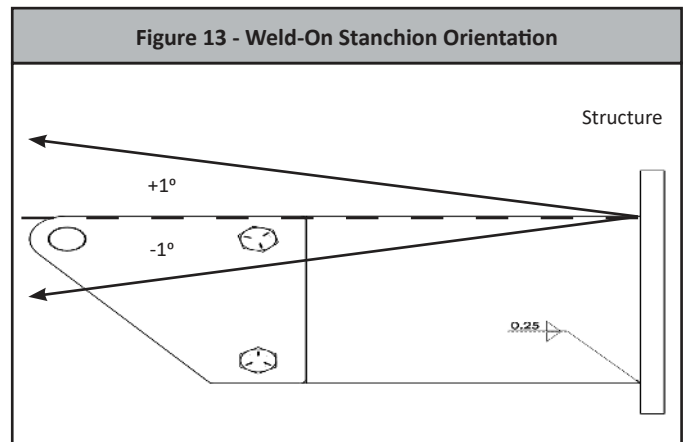
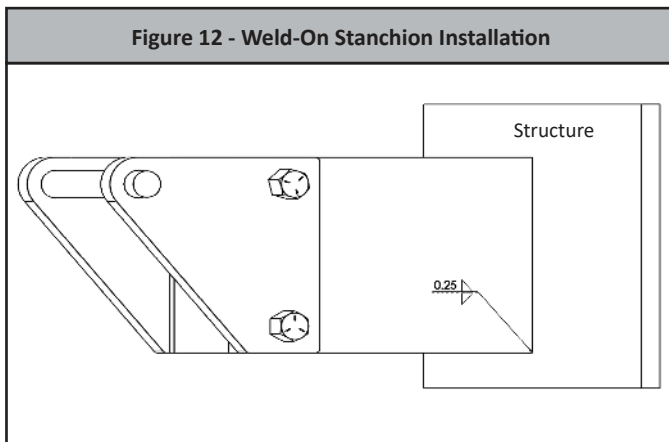

### 5.4 Rung Reinforcement Installation

All installations must be approved by a Qualified Person. Ensure the reinforced rungs, ladder, and structure meet all requirements detailed in this manual before installation of the Bolt-On Ladder Stanchion Anchor. The maximum allowable inside width of ladder rails is 20". Refer to Section 7.0 for inspection requirements to be completed before the use of this product.

**5.4.1** Identify the ladder rungs which the Bolt On Ladder Stanchion Anchor is to be installed on. Insert one reinforcement rod into each hollow rung requiring reinforcement. Install the included washers, hex nuts, and jam nuts onto each threaded rod in the order shown; see Figure 14. Snug inner hex nuts against ladder side rails and torque outer jam nuts against inner hex nuts to a minimum of 57 ft-lbs; see Figure 14.

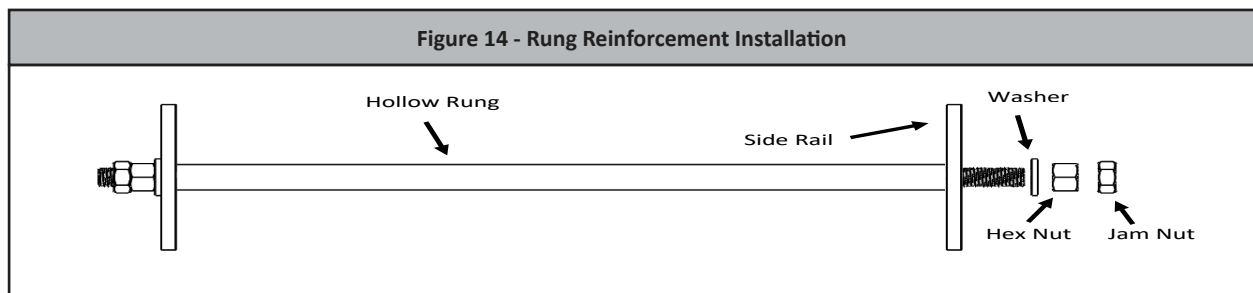

### 5.5 Product Use

The FallTech Ladder Stanchion Anchors shall only be used with FallTech Self-Retracting Devices (SRLs).

**5.5.1** A Pre-Use Inspection is required before the use of this product. Please refer to Section 7.0 for Pre-Use Inspection requirements.

**5.5.1** The user must maintain 100% tie-off while ascending and descending the climbing area, as well as when transitioning to or from the climbing area. Avoid swingfalls when climbing and transitioning from the climbing area. Use alternate fall protection when the Ladder Stanchion Anchor is not directly overhead.

**5.5.2** When not in use, the SRL needs to be kept fully retracted. A tagline is to be attached to the SRL snaphook in order to extract the cable to begin use. After use, slowly and uniformly retract the cable of the SRL. Do not allow the SRL cable to freewheel back into the unit.

## 6.0 Maintenance and Service

**6.1 Maintenance:** No scheduled maintenance is required, other than the replacement of items that fail inspection. The Ladder Stanchion Anchor and hardware may be cleaned with a damp rag and a mild soap and water solution. Wipe the hardware dry with a clean soft cloth. Do NOT use heat to dry. Do NOT use any solvents or petroleum products to clean.

**6.2 Service:** There are no specific service requirements for this system component.

## 7.0 Inspection

**7.1 Pre-Use Inspection:** FallTech® requires that the following steps be taken during each inspection prior to use of this product.

**7.1.1** Inspect the Stanchion Anchor and hardware. These items must not be damaged, broken, distorted, or have any sharp edges, burrs, cracks, worn parts, or corrosion.

**7.1.2** Look for rust, excessive dirt, grease, oil, paint, or other surface contamination or discoloring. If any condition exists that compromises the integrity of the anchor, immediately remove the anchor from service.

**7.1.3** Inspect the labels. All labels must be present and fully legible.

**7.1.4** Inspect each system component or subsystem according to the associated manufacturer's instructions.

**Do not use the Ladder Stanchion Anchor or additional equipment if any component fails any part of this inspection.**

### 7.2 Competent Person Inspection

**7.2.1** Inspect the additional equipment used with the Ladder Stanchion Anchor per the user instruction manual for the specific equipment. Do not use if the equipment fails inspection.

**7.2.2** Inspect the Ladder Stanchion Anchor thoroughly for damage, including but not limited to checking the structure for dents, weld integrity (if applicable), cracks, deformed or bent components, and corrosion.

**7.2.3** Inspect all hardware for damage, wear, or missing parts. Ensure all bolts are secured and properly torqued. Ensure all labels are present and legible.

**Do not use the Ladder Stanchion Anchor or additional equipment if any component fails any part of this inspection.**

### 7.3 Inspection Frequency:

**7.3.1 Pre-Use:** The Ladder Stanchion Anchor must be inspected by the user before use as outlined in Section 7.1.

**7.3.2 Competent Person:** The Ladder Stanchion Anchor must be inspected by a Competent Person prior to initial use and at least annually thereafter, as outlined in Section 7.2, and recorded on the Inspection Record provided on the following page or equivalent document.





## 9.0 Definitions

The following are general definitions of fall protection terms as defined by ANSI Z359.0-2012.

**Anchorage** - A secure connecting point or a terminating component of a fall protection system or rescue system capable of safely supporting the impact forces applied by a fall protection system or anchorage subsystem.

**Anchorage Connector** - A component or subsystem that functions as an interface between the anchorage and a fall protection, work positioning, rope access or rescue system for the purpose of coupling the system to the anchorage.

**Arrest Distance** - The total vertical distance required to arrest a fall. The arrest distance includes the deceleration distance and activation distance.

**Authorized Person** - A person assigned by the employer to perform duties at a location where the person will be exposed to a fall hazard.

**Available Clearance** - The distance from a reference point, such as the working platform, to the nearest obstruction that an authorized person might contact during a fall which, if struck, could cause injury.

**Capacity** - The maximum weight that a component, system or subsystem is designed to hold.

**Certification** - The act of attesting in writing that the criteria established by these standards or some other designated standard have been met.

**Certified Anchorage** - An anchorage for fall arrest, positioning, restraint or rescue systems that a qualified person certifies to be capable of supporting the potential fall forces that could be encountered during a fall.

**Clearance** - The distance from a specified reference point, such as the working platform or anchorage of a fall arrest system, to the lower level that a worker might encounter during a fall.

**Clearance Requirement** - The distance below an authorized person that must remain clear of obstructions in order to ensure that the authorized person does not make contact with any objects that would cause injury in the event of a fall.

**Competent Person** - An individual designated by the employer to be responsible for the immediate supervision, implementation and monitoring of the employer's managed fall protection program who, through training and knowledge, is capable of identifying, evaluating and addressing existing and potential fall hazards, and who has the employer's authority to take prompt corrective action with regard to such hazards.

**Component** - An element or integral assembly of interconnected elements intended to perform one function in the system.

**Connecting Subsystem** - An assembly, including the necessary connectors, comprised of all components, subsystems, or both, between the anchorage or anchorage connector and the harness attachment point.

**Connector** - A component or element that is used to couple parts of the system together.

**Deceleration Distance** - The vertical distance between the user's fall arrest attachment at the onset of fall arrest forces during a fall, and after the fall arrest attachment comes to a complete stop.

**Energy (Shock) Absorber** - A component whose primary function is to dissipate energy and limit deceleration forces which the system imposes on the body during fall arrest.

**Fall Arrest** - The action or event of stopping a free fall or the instant where the downward free fall has been stopped.

**Fall Hazard** - Any location where a person is exposed to a potential free fall.

**Free Fall** - The act of falling before a fall protection system begins to apply forces to arrest the fall.

**Free Fall Distance** - The vertical distance traveled during a fall, measured from the onset of a fall from a walking working surface to the point at which the fall protection system begins to arrest the fall.

**Harness, Full Body** - A body support designed to contain the torso and distribute the fall arrest forces over at least the upper thighs, pelvis, chest and shoulders.

**Horizontal Lifeline** - A component of a horizontal lifeline subsystem, consisting of a flexible line with connectors or other coupling means at both ends for securing it horizontally between two anchorages or anchorage connectors.

**Horizontal Lifeline Subsystem** - An assembly, including the necessary connectors, comprised of a horizontal lifeline component and, optionally, of:  
a) An energy absorbing component or, b) A lifeline tensioner component, or both. This subsystem is normally attached at each end to an anchorage or anchorage connector. The end anchorages have the same elevation.

**Horizontal Lifeline** – A component of a horizontal lifeline subsystem, consisting of a flexible line with connectors or other coupling means at both ends for securing it horizontally between two anchorages or anchorage connectors.

**Horizontal Lifeline Subsystem** – An assembly, including the necessary connectors, comprised of a horizontal lifeline component and, optionally, of:  
a) An energy absorbing component or, b) A lifeline tensioner component, or both. This subsystem is normally attached at each end to an anchorage or anchorage connector. The end anchorages have the same elevation.

**Lanyard** - A component consisting of a flexible rope, wire rope or strap, which typically has a connector at each end for connecting to the body support and to a fall arrester, energy absorber, anchorage connector or anchorage.

**Lanyard Connecting Subsystem** - An assembly, including the necessary connectors, comprised of a lanyard only, or a lanyard and energy absorber.

**Personal Fall Arrest System (PFAS)** - An assembly of components and subsystems used to arrest a person in a free fall.

**Positioning** - The act of supporting the body with a positioning system for the purpose of working with hands free.

**Positioning Lanyard** - A lanyard used to transfer forces from a body support to an anchorage or anchorage connector in a positioning system.

**Qualified Person** - A person with a recognized degree or professional certificate and with extensive knowledge, training and experience in the fall protection and rescue field who is capable of designing, analyzing, evaluating and specifying fall protection and rescue systems.

**Self-Retracting Device (SRD)** - A device that contains a drum wound line that automatically locks at the onset of a fall to arrest the user, but that pays out from and automatically retracts onto the drum during normal movement of the person to whom the line is attached.

**Snaphook** - A connector comprised of a hook-shaped body with a normally closed gate or similar arrangement that may be opened to permit the hook to receive an object and, when released, automatically closes to retain the object.

**Swing Fall** - A pendulum-like motion that occurs during and/or after a vertical fall. A swing fall results when an authorized person begins a fall from a position that is located horizontally away from a fixed anchorage.

## APPENDIX A

**Table 1: Specifications for Ladder Stanchion Anchors**

Material	Minimum Tensile Strength	Maximum User Capacity	Standards & Regulations
Galvanized Steel	3,600 lbs	Maximum One Worker 425 lbs.	OSHA 1910.140, 1926.502

**Table 2: Dimensions of Ladder Stanchion Anchors**

Item Number	Height (A)	Offset (B)
6161012	10'	12"
6161005	10'	5"
6160505	5'	5"
6160512	5'	12"
6160512W	5 ½"	12"

