

Confined Space Davit Vehicle Hitch Mounts and Accesories

User Instruction Manual

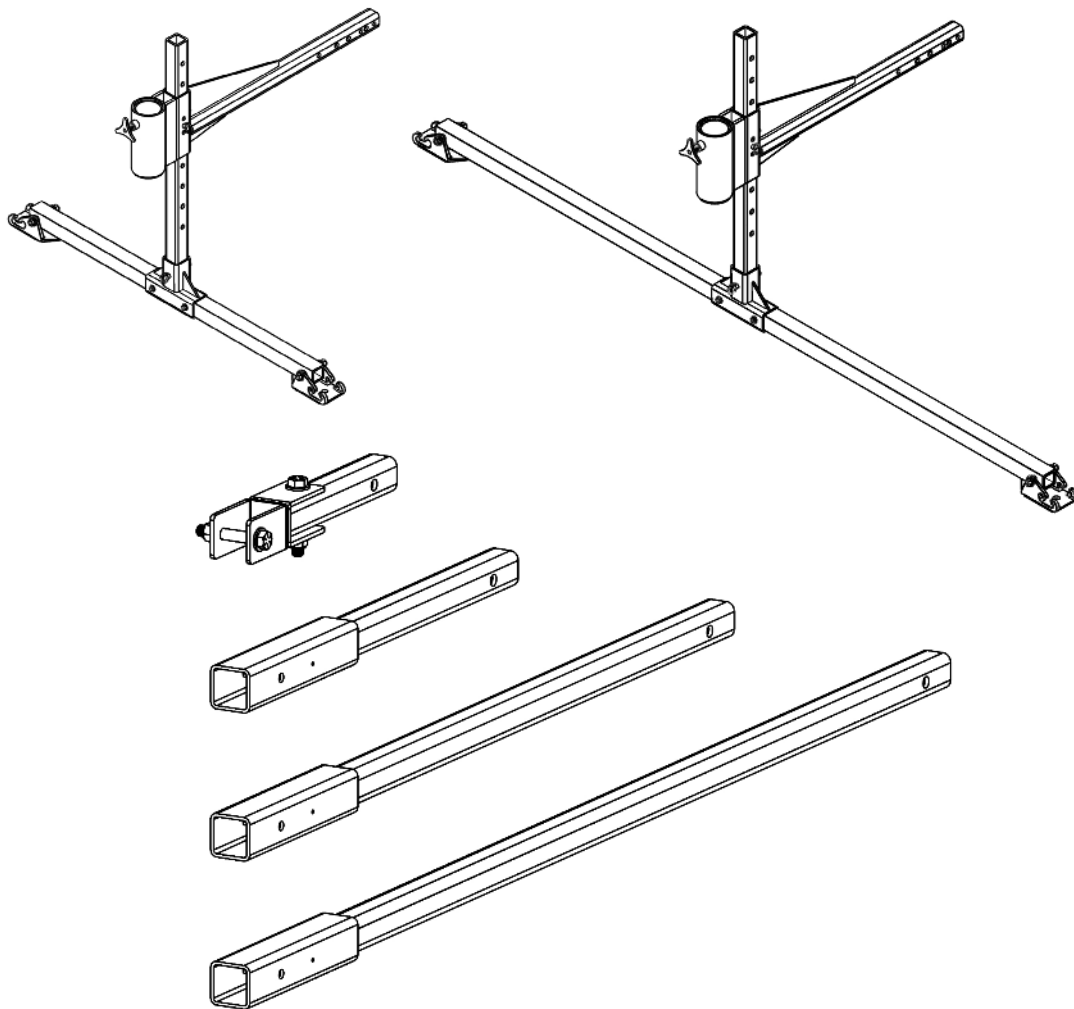

This manual is intended to meet the Manufacturer's Instructions as required by the American National Standards Institute (ANSI) Z359 and should be used as part of an employee training program as required by the Occupational Safety and Health Administration (OSHA).

Table of Contents

1.0	Warnings and Important Information	3
2.0	Application	4
3.0	System Requirements	5
4.0	Installation and Use	5
5.0	Maintenance, Service, and Storage	9
6.0	Inspection	9
7.0	Labels	11
8.0	Definitions	12
	Appendix A	14

For the purposes of this manual, the Confined Space Vehicle Hitch Mount may be referred to as the Vehicle Hitch Mount, hitch mount, base, sleeve, product, or the system.

Throughout this manual, ANSI Z359.0-2012 fall protection words, phrases and terms are used. These terms are all formally defined in Section 8.0 of this manual.

1.0 Warnings and Important Information

WARNING

- Avoid moving machinery, thermal, electrical and/or chemical hazards as contact may cause serious injury or death.
- Avoid swing falls.
- Follow the weight restrictions and recommendations in this manual.
- Remove from service any equipment subjected to fall arrest forces.
- Remove from service any equipment that fails inspection.
- Do not alter or intentionally misuse this equipment.
- Consult FallTech when using this equipment in combination with components or subsystems other than those described in this manual.
- Do not connect rebar hooks, large carabiners, or large snap hooks to the FBH dorsal D-rings as this may cause a roll-out condition and/or unintentional disengagement.
- Avoid sharp and/or abrasive surfaces and edges.
- Use caution when performing arc welding. Arc flash from arc welding operations, including accidental arcs from electrical equipment, can damage equipment and are potentially fatal.
- Examine the work area. Be aware of the surroundings and workplace hazards that may impact safety, security, and the functioning of fall arrest systems and components.
- Hazards may include but not be limited to cable or debris tripping hazards, equipment failures, personnel mistakes, moving equipment such as carts, barrows, fork lifts, cranes, or dollies. Do not allow materials, tools or equipment in transit to contact any part of the fall arrest system.
- Do not work under suspended loads.

IMPORTANT

This product is part of a personal fall arrest, restraint, work positioning, suspension, or rescue system. A Personal Fall Arrest System (PFAS) is typically composed of an anchorage and a Full Body Harness (FBH), with a connecting device, i.e., a Shock Absorbing Lanyard (SAL), or a Self-Retracting Device (SRD), attached to the dorsal D-ring of the FBH.

These instructions must be provided to the worker using this equipment. The worker must read and understand the manufacturer's instructions for each component or part of the complete system. Manufacturer's instructions must be followed for proper use, care, and maintenance of this product. These instructions must be retained and be kept available for the worker's reference at all times. Alterations or misuse of this product, or failure to follow instructions, may result in serious injury or death.

A Fall Protection Plan must be on file and available for review by all workers. It is the responsibility of the worker and the purchaser of this equipment to assure that users of this equipment are properly trained in its use, maintenance, and storage. Training must be repeated at regular intervals. Training must not subject the trainee to fall hazards.

Consult a doctor if there is reason to doubt your fitness to safely absorb the shock of a fall event. Age and fitness seriously affect a worker's ability to withstand falls. Pregnant women or minors must not use this equipment.

ANSI limits the weight of fall protection equipment users to a maximum of 310 lbs. Products in this manual may have a rated capacity exceeding ANSI capacity limits. Heavy users experience more risk of serious injury or death due to falls because of increased fall arrest forces placed on the user's body. In addition, the onset of suspension trauma after a fall event may be accelerated for heavy users.

The user of the equipment discussed in this manual must read and understand the entire manual before beginning work.

NOTE: For more information consult the ANSI Z359 body of standards.

2.0 Application

- 2.1 Description:** The FallTech Confined Space Vehicle Hitch Mount and Accesories, see Figure 1, is designed for use with a Class 3 or higher trailer hitch with a 2 in. square hitch receiver on a vehicle weighing more than 2,000 lbs.
- 2.2 Purpose:** The FallTech Vehicle Hitch Mount, depending on configuration, is designed to work with the FallTech Davit Arms, a FallTech 21 in. or 33 in. Mast Extension and accesories as part of a system to raise or lower a person to work in a confined space for entry, retrieval, fall arrest, and material handling. **Only one extension should be used at a time with the Vehicle Hitch Mount for 12" to 29" Offset Davit Arm and the Vehicle Hitch Mount for 24" to 44" Offset Davit Arm.** See Table 2 for compatibility information.
- 2.3 Application Limits:** The Vehicle Hitch Mount is a dynamic anchorage system that will vary in its performance depending upon the offset the user configures. Care should be taken to understand the capacity of the system and anchorage strength requirements. See Tables 1 and 2 for specification and compatibility information.
- 2.4 System Capacity:** Both the Vehicle Hitch Mount for 12" to 29" Offset Davit Arm and the Vehicle Hitch Mount for 24" to 44" Offset Davit Arm have been tested to a moment load of 5,750 ft-lbs and are suitable for use with all configurations of the FallTech 12" to 29" Offset Davit Arm. The Vehicle Hitch Mount for 24" to 44" Offset Davit Arm is suitable for use with the FallTech 24" to 44" Offset Davit Arm when restricted to **Pin Position 1 and 2**. See MCS30 for the specific load ratings by configuration. The maximum capacity of the FallTech Confined Space Davit is one worker for confined space entry and egress, with the worker weighing no more than 310lbs (140kg) including clothing, tools, etc. For rescue applications, the FallTech Confined Space Davit has a maximum capacity of two workers with each worker weighing no more than 310lbs including clothing, tools, etc.
- 2.5 Davit Anchorage Strength:** When using the FallTech Confined Space Davit with the Vehicle Hitch Mount, the mounting surface must support 5,000 lbs. The vehicle used with the Vehicle Hitch Mount must have a Class 3 or higher vehicle trailer hitch. Typical vehicles that have a Class 3 trailer hitch are mid-size and larger SUVs, pickup trucks, and vans.

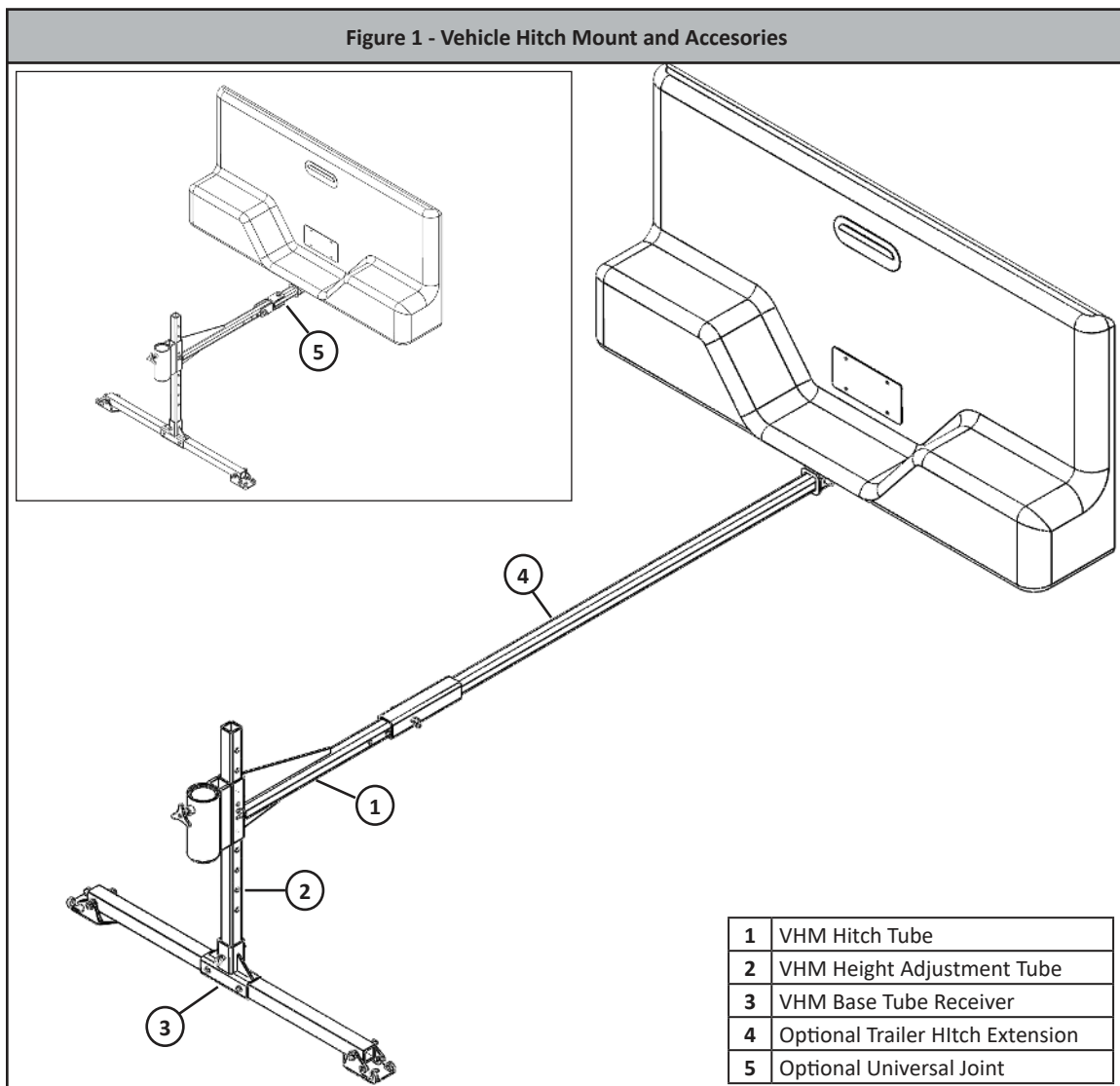

3.0 System Requirements

3.1 Compatibility of Connectors: Connectors are considered to be compatible with connecting elements when they have been designed to work together in such a way that their sizes and shapes do not cause their gate mechanisms to inadvertently open regardless of how they become oriented. Contact FallTech if you have any questions about compatibility. Connectors must be compatible with the anchorage or other system components. Do not use equipment that is not compatible. Non-compatible connectors may unintentionally disengage, see Figure 2. Connectors must be compatible in size, shape, and strength. Self-closing, self-locking snap hooks and carabiners are specified by OSHA and ANSI Z359.12.

3.2 Compatibility of Components: Equipment is designed for use with approved components and subsystems only. Substitutions or replacements made with non-ANSI Z359 compliant components or subsystems may jeopardize compatibility of equipment and may affect the safety and reliability of the complete system. Ensure compatibility between the connectors if non-FallTech components are used for fall protection.

3.3 Connectors: Only use self-locking snap hooks, rebar hooks, and carabiners with this equipment. Only use connectors that are suitable to each application. Ensure all connections are compatible in size, shape, and strength. Do not use equipment that is not compatible. Visually ensure all connectors close and lock completely. Connectors (snap hooks, rebar hooks, and carabiners) are designed for use only as specified in this manual.

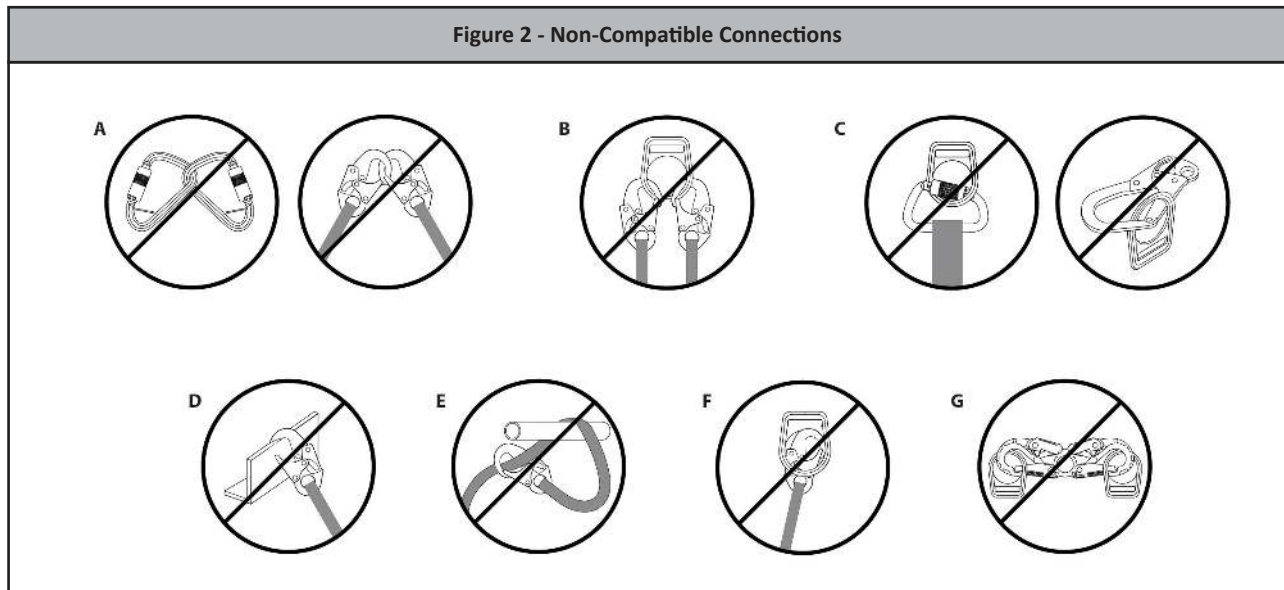

4.0 Installation and Use

4.1 Vehicle Hitch Mount Assembly

Step 1 - Vehicle

Ensure the vehicle to be used with the FallTech Vehicle Hitch Mount has a Class 3 or higher vehicle trailer hitch. Class 3 trailer hitches mount to the vehicle frame and have a 2 in. square receiver opening. Typical vehicles that have a Class 3 trailer hitch are mid-size and larger SUVs, pickup trucks, and vans.

Step 2 - Vehicle Attachment

Park the vehicle on level ground in a location applicable to the job site. Place the vehicle transmission in Park and engage the parking brake. Lock out/tag out the vehicle.

Insert the Hitch Tube into the Class 3 or greater trailer hitch, see Figure 3-(1), and secure it to the hitch receiver with a trailer hitch pin or nut and bolt, see Figure 3-(2).

Insert the Height Adjustment Tube into the Hitch Tube, see Figure 4-(3), align the Base Tube receiver with the Height Adjustment Tube and insert the detent pin, see Figure 5-(4).

Step 3 - Leveling

Level the Vehicle Hitch Mount assembly to ensure the Hitch Tube is parallel with the ground by inserting the detent pin into the appropriate hole, see Figure 5-(5).

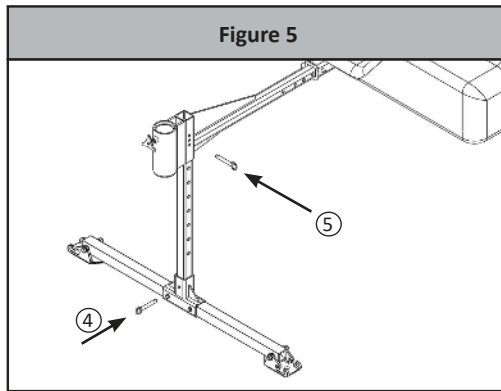
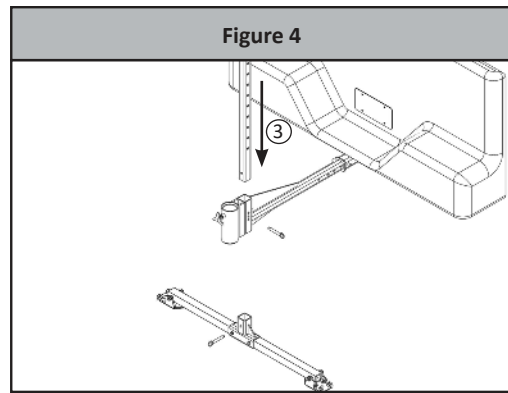
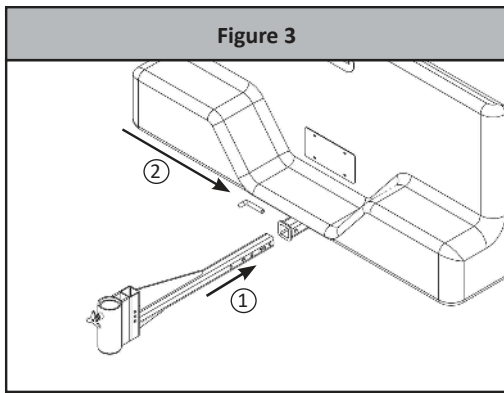

4.2 Vehicle Hitch Mount with Optional Extensions

Step 1 - Vehicle

Ensure the vehicle to be used with the FallTech Vehicle Hitch Mount has a Class 3 or higher vehicle trailer hitch. Class 3 trailer hitches mount to the vehicle frame and have a 2 in. square receiver opening. Typical vehicles that have a Class 3 trailer hitch are mid-size and larger SUVs, pickup trucks, and vans.

Step 2 - Vehicle Attachment

Park the vehicle on level ground in a location applicable to the job site. Place the vehicle transmission in Park and engage the parking brake. Lock out/tag out the vehicle.

Insert the Hitch Tube Extension into the Class 3 or greater trailer hitch, see Figure 6-(1), and secure it to the hitch receiver with a trailer hitch pin or nut and bolt, see Figure 6-(2).

Insert the Hitch Tube into the Hitch Tube Extension, see Figure 7-(3), and secure it to the Hitch Tube Extension with the supplied detent pin, see Figure 7-(4).

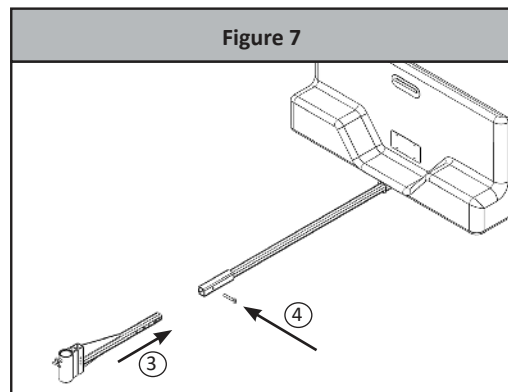
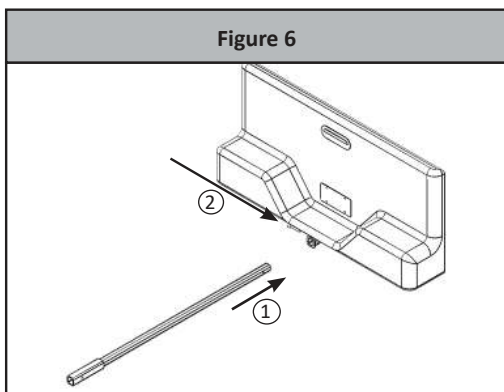

Note: Only one extension should be used at a time.

Insert the Height Adjustment Tube into the Hitch Tube, see Figure 8-(5). Align the Base Tube receiver with the Height Adjustment Tube and insert the detent pin, see Figure 9-(6).

Step 3 - Leveling

Level the Vehicle Hitch Mount assembly to ensure the Hitch Tube is parallel with the ground by inserting the detent pin into the appropriate hole, see Figure 9-(7).

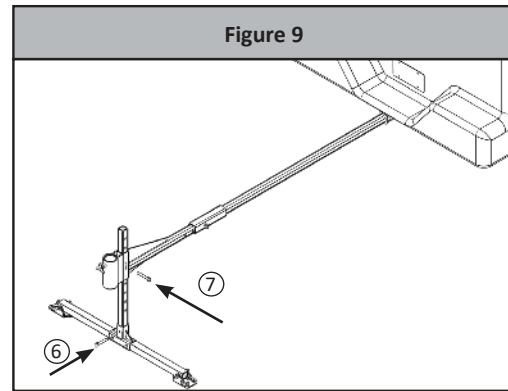
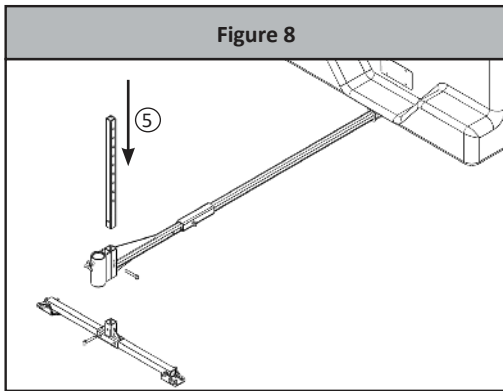

4.3 Vehicle Hitch Mount with Optional Universal Joint

Step 1 - Vehicle

Ensure the vehicle to be used with the FallTech Vehicle Hitch Mount has a Class 3 or higher vehicle trailer hitch. Class 3 trailer hitches mount to the vehicle frame and have a 2 in. square receiver opening. Typical vehicles that have a Class 3 trailer hitch are mid-size and larger SUVs, pickup trucks and vans.

Step 2 - Vehicle Attachment

Park the vehicle on level ground in a location applicable to the job site. Place the vehicle transmission in Park and engage the parking brake. Lock out/tag out the vehicle.

Install the Universal Joint onto the Hitch Tube, see Figure 10-(1), use the supplied nuts, bolts, and washers bolt the Universal Joint and Hitch Tube together, see Figure 10(2). Tighten the bolt to to 30 ft. lbs.

Insert the Universal Joint with the attached Hitch Tube into the Class 3 or greater trailer hitch, see Figure 11-(3) and secure it to the hitch receiver with a trailer hitch pin or nut and bolt, see Figure 11-(4).

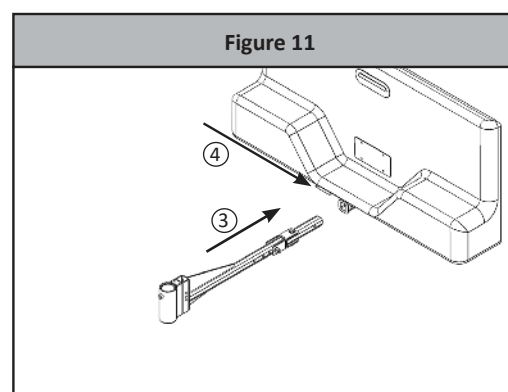
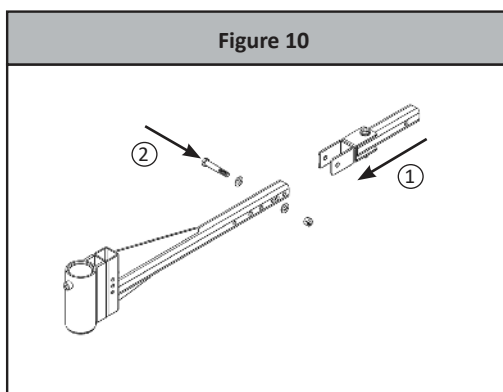

Insert the Height Adjustment Tube into the Hitch Tube, see Figure 12-(5). Align the Base Tube receiver with the Height Adjustment Tube and insert the detent pin, see Figure 13-(6).

Step 3 - Leveling

Level the Vehicle Hitch Mount assembly to ensure the Hitch Tube is parallel with the ground by inserting the detent pin into the appropriate hole, see Figure 13-(7).

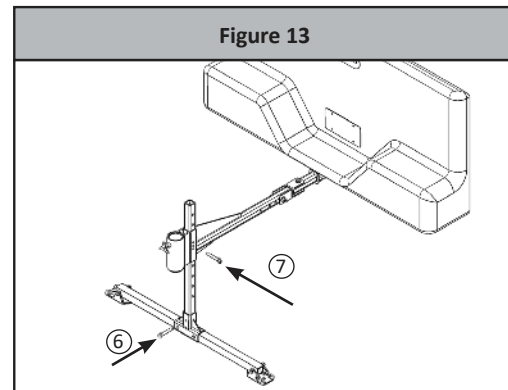
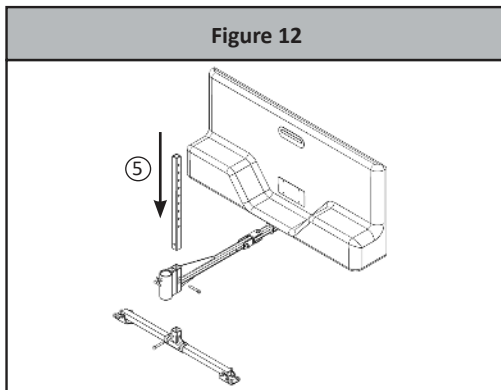

Note: The Universal Joint can be used with any one extension. The Universal Joint must be inserted into a class 3 or higher vehicle hitch and then bolted to the chosen extension, see Figure 14.

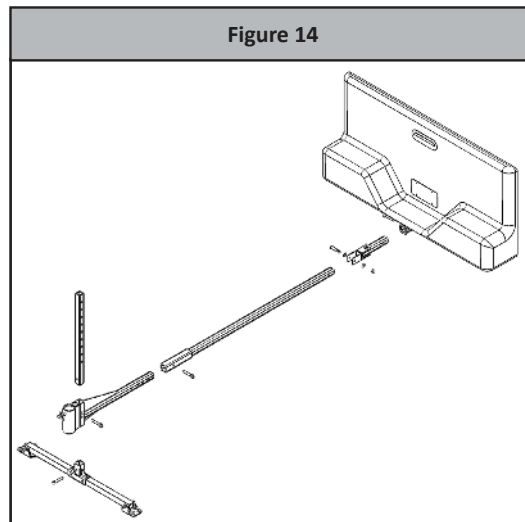

4.4 Davit Arm and Lower Mast Extension Installation

Insert the Lower Mast Extension into the Vehicle Hitch Mount as shown in Figure 15. The 21" or 33" Lower Mast Extensions can be used on the Vehicle Hitch Mount Base for 12" to 29" Offset Davit Arm. Only the 21" Lower Mast Extension can be used on the Vehicle Hitch Mount Base for 24" to 44" Offset Davit Arm. Do not use any other Lower Mast Extension when setting up the davit arm. **See Appendix A, Table 2 for compatible Davit Arms and Lower Mast Extensions.**

Lift the Davit Arm and place it onto the Lower Mast Extension, see Figure 16. Ensure the bolt on the Lower Mast Extension fits into the Davit Arm mating notch as shown in Figure 17.

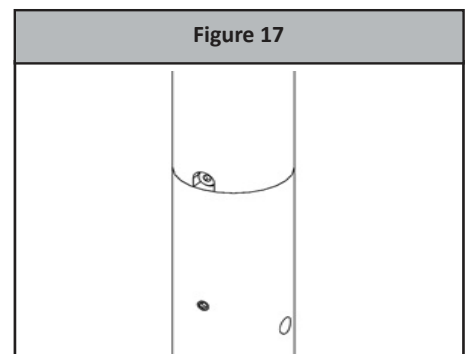
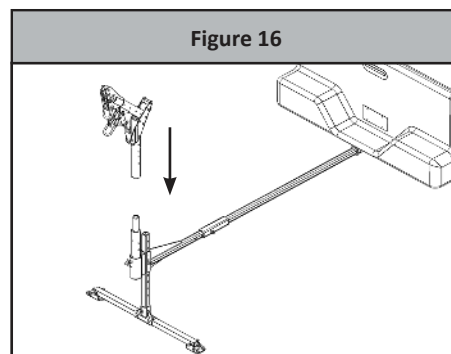
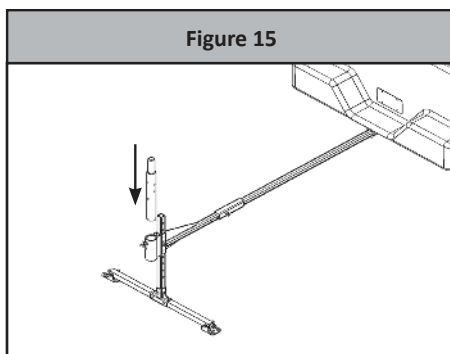

5.0 Maintenance, Service and Storage

Maintenance: No scheduled maintenance is required, other than the replacement of items that failed inspection.

Service: There are no specific service requirements for this system component.

Storage: If the unit is removed from its installation location, it should be stored in a dry area free of corrosive elements that may harm or cause the product not to function.

6.0 Inspection

6.1 Pre-Use Inspection:

- 6.1.1 Inspect the additional equipment used with the Vehicle Hitch Mount per the user instruction manual for the specific equipment. Do not use if the equipment fails inspection.
- 6.1.2 Inspect Vehicle Hitch Mount thoroughly for damage. Inspection should include checking the structure for dents, cracks, deformed or bent tubing, and welded areas for cracks.
- 6.1.3 Inspect all hardware for damage, wear, or missing parts.
- 6.1.4 Check vehicle hitch receiver tube to ensure proper fit. Check for damage such as dents, cracks, chips, excessive wear, cracks in welded areas, or rust.

Do not use the Vehicle Hitch Mount or additional equipment if any part fails this inspection.

6.2 Inspection Frequency:

Pre-Use: Inspect the Vehicle Hitch Mount and additional equipment before use as outlined in section 6.1. All installations must be approved by a Qualified Person to local standards.

Annually: The Vehicle Hitch Mount and additional equipment must be inspected by a Qualified Person annually and recorded on the Inspection Record provided or equivalent document.

6.3 Inspection Document: Record inspection results on the Inspection Record provided below or on a similar document.

<h2 style="margin: 0;">Inspection Record</h2>					
Model #: _____		Serial #: _____		Date of Manufacture: _____	
INSPECTION DATE	INSPECTOR	COMMENTS	PASS/FAIL	CORRECTIVE ACTION NEEDED	APPROVED BY

8.0 Definitions

The following are general definitions of fall protection terms as defined by ANSI Z359.0-2012.

Anchorage - A secure connecting point or a terminating component of a fall protection system or rescue system capable of safely supporting the impact forces applied by a fall protection system or anchorage subsystem.

Anchorage Connector - A component or subsystem that functions as an interface between the anchorage and a fall protection, work positioning, rope access or rescue system for the purpose of coupling the system to the anchorage.

Arrest Distance - The total vertical distance required to arrest a fall. The arrest distance includes the deceleration distance and activation distance.

Authorized Person - A person assigned by the employer to perform duties at a location where the person will be exposed to a fall hazard.

Available Clearance - The distance from a reference point, such as the working platform, to the nearest obstruction that an authorized person might contact during a fall which, if struck, could cause injury.

Capacity - The maximum weight that a component, system or subsystem is designed to hold.

Certification - The act of attesting in writing that the criteria established by these standards or some other designated standard have been met.

Certified Anchorage - An anchorage for fall arrest, positioning, restraint or rescue systems that a qualified person certifies to be capable of supporting the potential fall forces that could be encountered during a fall.

Clearance - The distance from a specified reference point, such as the working platform or anchorage of a fall arrest system, to the lower level that a worker might encounter during a fall.

Clearance Requirement - The distance below an authorized person that must remain clear of obstructions in order to ensure that the authorized person does not make contact with any objects that would cause injury in the event of a fall.

Competent Person - An individual designated by the employer to be responsible for the immediate supervision, implementation and monitoring of the employer's managed fall protection program who, through training and knowledge, is capable of identifying, evaluating and addressing existing and potential fall hazards, and who has the employer's authority to take prompt corrective action with regard to such hazards.

Component - An element or integral assembly of interconnected elements intended to perform one function in the system.

Connecting Subsystem - An assembly, including the necessary connectors, comprised of all components, subsystems, or both, between the anchorage or anchorage connector and the harness attachment point.

Connector - A component or element that is used to couple parts of the system together.

Deceleration Distance - The vertical distance between the user's fall arrest attachment at the onset of fall arrest forces during a fall, and after the fall arrest attachment comes to a complete stop.

Energy (Shock) Absorber - A component whose primary function is to dissipate energy and limit deceleration forces which the system imposes on the body during fall arrest.

Fall Arrest - The action or event of stopping a free fall or the instant where the downward free fall has been stopped.

Fall Hazard - Any location where a person is exposed to a potential free fall.

Free Fall - The act of falling before a fall protection system begins to apply forces to arrest the fall.

Free Fall Distance - The vertical distance traveled during a fall, measured from the onset of a fall from a walking working surface to the point at which the fall protection system begins to arrest the fall.

Harness, Full Body - A body support designed to contain the torso and distribute the fall arrest forces over at least the upper thighs, pelvis, chest and shoulders.

Horizontal Lifeline - A component of a horizontal lifeline subsystem, consisting of a flexible line with connectors or other coupling means at both ends for securing it horizontally between two anchorages or anchorage connectors.

Horizontal Lifeline Subsystem - An assembly, including the necessary connectors, comprised of a horizontal lifeline component and, optionally, of:
a) An energy absorbing component or, b) A lifeline tensioner component, or both. This subsystem is normally attached at each end to an anchorage or anchorage connector. The end anchorages have the same elevation.

Horizontal Lifeline – A component of a horizontal lifeline subsystem, consisting of a flexible line with connectors or other coupling means at both ends for securing it horizontally between two anchorages or anchorage connectors.

Horizontal Lifeline Subsystem – An assembly, including the necessary connectors, comprised of a horizontal lifeline component and, optionally, of:
a) An energy absorbing component or, b) A lifeline tensioner component, or both. This subsystem is normally attached at each end to an anchorage or anchorage connector. The end anchorages have the same elevation.

Lanyard - A component consisting of a flexible rope, wire rope or strap, which typically has a connector at each end for connecting to the body support and to a fall arrester, energy absorber, anchorage connector or anchorage.

Lanyard Connecting Subsystem - An assembly, including the necessary connectors, comprised of a lanyard only, or a lanyard and energy absorber.

Personal Fall Arrest System (PFAS) - An assembly of components and subsystems used to arrest a person in a free fall.

Positioning - The act of supporting the body with a positioning system for the purpose of working with hands free.

Positioning Lanyard - A lanyard used to transfer forces from a body support to an anchorage or anchorage connector in a positioning system.

Qualified Person - A person with a recognized degree or professional certificate and with extensive knowledge, training and experience in the fall protection and rescue field who is capable of designing, analyzing, evaluating and specifying fall protection and rescue systems.

Self-Retracting Device (SRD) - A device that contains a drum wound line that automatically locks at the onset of a fall to arrest the user, but that pays out from and automatically retracts onto the drum during normal movement of the person to whom the line is attached.

Snaphook - A connector comprised of a hook-shaped body with a normally closed gate or similar arrangement that may be opened to permit the hook to receive an object and, when released, automatically closes to retain the object.

Swing Fall - A pendulum-like motion that occurs during and/or after a vertical fall. A swing fall results when an authorized person begins a fall from a position that is located horizontally away from a fixed anchorage.

The following are general definitions of fall protection terms as defined by OSHA 1910.146.

Confined Space - OSHA defines a Confined Space as:

- Is large enough for an employee to enter fully and perform assigned work;
- Is not designed for continuous occupancy by the employee; and
- Has a limited or restricted means of entry or exit.

These spaces may include underground vaults, tanks, storage bins, pits and diked areas, vessels, silos and other similar areas.

Permit Required Confined Space has one or more of these characteristics:

- Contains or has the potential to contain a hazardous atmosphere;
- Contains a material with the potential to engulf someone who enters the space;
- Has an internal configuration that might cause an entrant to be trapped or asphyxiated by inwardly converging walls or by a floor that slopes downward and tapers to a smaller cross section; and/or
- Contains any other recognized serious safety or health hazards.

APPENDIX A

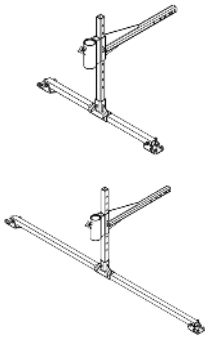
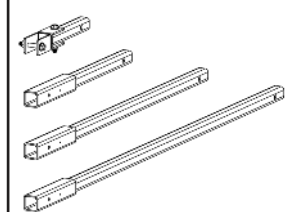
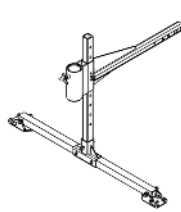





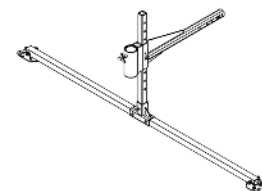

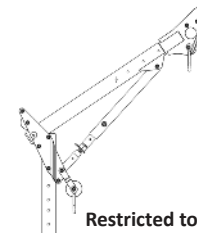

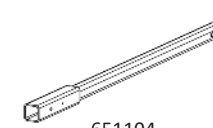
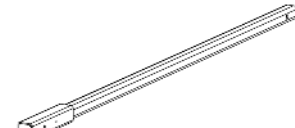
Table 1: Specifications for Confined Space Davit Vehicle Hitch Mount				
Part Numbers	Minimum Tensile Strength and Material	Maximum User Capacity	Standards & Regulations	Image
6501528 6501644	6061-T6 Aluminum Zinc Plated Steel Minimum 5,750 ft-lb Moment Rated	Maximum Two Workers at up to 310 lbs. Each (620 lbs Total) for Rescue Configurations Maximum One Worker up to 310 lbs. for Normal Confined Space Entry/ Egress Operations	OSHA 1926.502	
651101U 651102 651104 651106	Zinc Plated Steel	See MCS30 for More Details		

Table 2: Vehicle Hitch Mount Compatibility Chart			
Vehicle Hitch Mount	Compatible Davit Arms	Compatible Lower Mast Extension	Compatible Extensions
 6501528 3pc Vehicle Hitch Mount Base for 12" to 29" Offset Davit Arm	 6500128 12" to 29" Offset Davit Arm	 6500321 21" Lower Mast Extension  6500433 33" Lower Mast Extension	 651101U Vehicle Hitch Mount Universal Joint Adapter  651102 2' Vehicle Hitch Mount Extender
 6501644 3pc Vehicle Hitch Mount Base for 24" to 44" Offset Davit Arm	 6500128 12" to 29" Offset Davit Arm  6500244 24" to 44" Offset Davit Arm Restricted to PP1 and PP2	 6500321 21" Lower Mast Extension	 651104 4' Vehicle Hitch Mount Extender  651106 6' Vehicle Hitch Mount Extender

Note: Only one extension or universal joint adapter should be used at a time.