

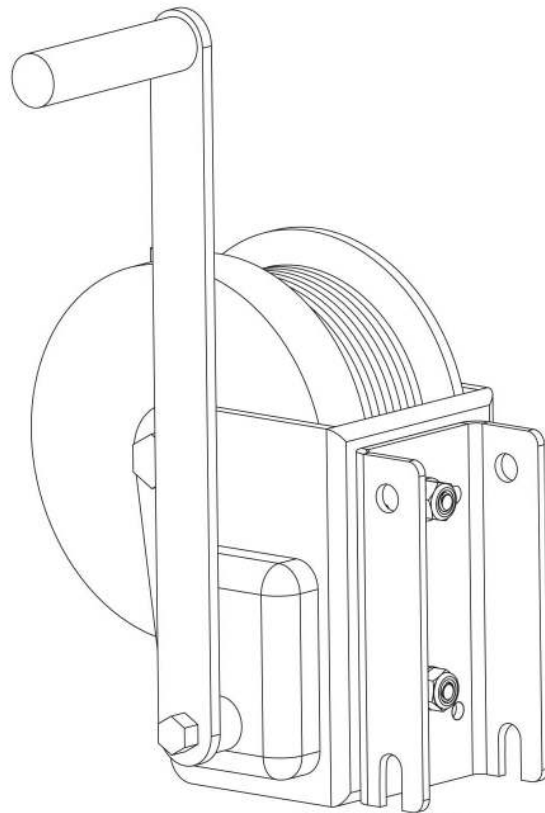

FALLTECH[®]
Fall Protection, Precision Engineered.

Confined Space Material Winch

User Instruction Manual



This manual is intended to meet the Manufacturer's Instructions as required by the American National Standards Institute (ANSI) Z359 and should be used as part of an employee training program as required by the Occupational Safety and Health Administration (OSHA).

WARNING

- Avoid moving machinery, thermal, electrical and/or chemical hazards as contact may cause serious injury or death.
- Avoid swing falls.
- Follow the weight restrictions and recommendations in this manual.
- Remove from service any equipment subjected to fall arrest forces.
- Remove from service any equipment that fails inspection.
- Do not alter or intentionally misuse this equipment.
- Consult FallTech when using this equipment in combination with components or subsystems other than those described in this manual.
- Do not connect rebar hooks, large carabiners, or large snap hooks to the FBH dorsal D-rings as this may cause a roll-out condition and/or unintentional disengagement.
- Avoid sharp and/or abrasive surfaces and edges.
- Use caution when performing arc welding. Arc flash from arc welding operations, including accidental arcs from electrical equipment, can damage equipment and are potentially fatal.
- Examine the work area. Be aware of the surroundings and workplace hazards that may impact safety, security, and the functioning of fall arrest systems and components.
- Hazards may include but not be limited to cable or debris tripping hazards, equipment failures, personnel mistakes, moving equipment such as carts, barrows, fork lifts, cranes, or dollies. Do not allow materials, tools or equipment in transit to contact any part of the fall arrest system.
- Do not work under suspended loads.

IMPORTANT

This product is part of a personal fall arrest, restraint, work positioning, suspension, or rescue system. A Personal Fall Arrest System (PFAS) is typically composed of an anchorage and a Full Body Harness (FBH), with a connecting device, i.e., a Shock Absorbing Lanyard (SAL), or a Self-Retracting Device (SRD), attached to the dorsal D-ring of the FBH.

These instructions must be provided to the worker using this equipment. The worker must read and understand the manufacturer's instructions for each component or part of the complete system. Manufacturer's instructions must be followed for proper use, care, and maintenance of this product. These instructions must be retained and be kept available for the worker's reference at all times. Alterations or misuse of this product, or failure to follow instructions, may result in serious injury or death.

A Fall Protection Plan must be on file and available for review by all workers. It is the responsibility of the worker and the purchaser of this equipment to assure that users of this equipment are properly trained in its use, maintenance, and storage. Training must be repeated at regular intervals. Training must not subject the trainee to fall hazards.

Consult a doctor if there is reason to doubt your fitness to safely absorb the shock of a fall event. Age and fitness seriously affect a worker's ability to withstand falls. Pregnant women or minors must not use this equipment.

ANSI limits the weight of fall protection equipment users to a maximum of 310 lbs. Products in this manual may have a rated capacity exceeding ANSI capacity limits. Heavy users experience more risk of serious injury or death due to falls because of increased fall arrest forces placed on the user's body. In addition, the onset of suspension trauma after a fall even may be accelerated for heavy users.

The user of the equipment discussed in this manual must read and understand the entire manual before beginning work.

NOTE: For more information consult the ANSI Z359 body of standards.

Table of Contents

1. DESCRIPTION

1.1 American National Standards Institute (ANSI) and Occupational Safety and Health Administration (OSHA)

2. APPLICATION

2.1 Purpose
2.2 Application Limits

3. SYSTEM REQUIREMENTS

3.1 Capacity
3.2 Compatibility Of Connectors
3.3 Compatibility Of Components
3.4 Making Connections

3.5 Material Handling

3.5.4 Rescue
3.6 Definitions

4. INSTALLATION AND OPERATION

4.1 General Installation Requirements
4.2 Install The Winch Onto The Anchorage Structure
4.3 Use The Winch

5. SPECIFICATIONS

6. MAINTENANCE AND STORAGE

7. INSPECTION OF WINCH

8. LABELS

Appendix A

1. DESCRIPTION

The FallTech® Confined Space Material Winch is primarily for those working in confined spaces, both permit and non-permit, and is to be used as part of a material handling system. The material winch is intended for material only, and is not to be used for the entry/egress of personnel in confined spaces.

The material winch is composed of a steel frame, gears, and shaft and a steel winch handle, with galvanized wire rope cable. The frame is bolted to a mating bracket to facilitate installation onto an anchorage structure such as a tripod or davit or other suitable anchor structures.

This manual contains one appendix. Appendix A provides figures and tables specific to the winch discussed in this manual. All figures, tables, and chart references in this manual are to Appendix A unless otherwise noted.

For purposes of this manual, the FallTech® Confined Space Material Winch, in all iterations, may be referred to collectively as the material winch, the equipment, the product, or the unit.

See Table 1 for products, materials, specifications and ratings. See Figure 1 for an illustration of the product parts and features.

1.1 American National Standards Institute (ANSI) and Occupational Safety and Health Act (OSHA): The winch discussed in this manual, including all devices attached to it, meets the standards of ANSI A10.5-1969 and OSHA regulations for construction 1926.502.

OSHA requires all employees working in a confined space application be trained regarding the nature of hazards involved, the necessary precautions to be taken, and in the use of protective and emergency equipment.

2. APPLICATION

2.1 Purpose: A typical confined space application is a support structure set up over an entry port, equipped with a confined space system. The winch discussed in this manual is part of a system to help facilitate lowering and raising material in and out of confined spaces. This material winch is not to be used for personnel entry/egress.

The winch operator directs the cable, and maintains constant contact with an entrant in the confined space to direct the material.

Entrant should not work below the suspended load.

Do not use the anchorage structure for material handling and entrant entry/egress at the same time.

2.2 Application Limits: Take action to avoid sharp edges, rough, abrasive or corroded surfaces and edges, and thermal, electrical and chemical hazards. Ensure the winch is properly attached to a support structure as specified in this manual.

When used with a FallTech anchorage structure, the winch is rated for 620 lbs.

3. SYSTEM REQUIREMENTS

3.1 Capacity: The capacity of the FallTech® Confined Space Material Winch is 620 lbs.

3.1.1 Material Handling: A structure used for material handling must be able to support a static load of 2,500 lbs or 4:1 safety factor applied in the direction permitted by the system.

3.2 Compatibility Of Connectors: Connectors are considered compatible with connecting elements when they have been designed to work together in such a way that their sizes and shapes do not cause their gate mechanisms to open inadvertently, regardless of how they become oriented. Contact FallTech if you have any questions about compatibility. Connectors must be compatible with the anchorage or other system components. Do not use equipment that is not compatible. Non-compatible connectors may unintentionally disengage. Connectors must be compatible in size, shape, and strength. Self-closing, self-locking snap hooks and carabiners are required by OSHA.

3.3 Compatibility Of Components: Equipment is designed for use with approved components and subsystems only. Substitutions or replacements made with non-approved components or subsystems may jeopardize compatibility of equipment and may affect the safety and reliability of the complete system.

3.4 Making Connections: Only use self-locking snap hooks and carabiners with this equipment. Only use connectors that are suitable to each application. Ensure all connections are compatible in size, shape and strength. Do not use equipment that is not compatible. Visually ensure all connectors are fully closed and locked. Connectors (snap hooks and carabiners) are designed for use only as specified in the user instruction manual provided with each product.

DO NOT use rebar hooks or any large-throat opening hooks with this winch.

3.6 Definitions: The following are definitions of terms as defined in ANSI Z359.0-2012.

Authorized Person: A person assigned by the employer to perform duties at a location where the person will be exposed to a fall hazard (otherwise referred to as “user” for the purpose of these instructions).

Certified Anchorage: An anchorage for fall protection, positioning, restraint, or rescue systems that a qualified person certifies to be capable of supporting the potential fall forces that could be encountered during a fall or that meet the criteria for a certified anchorage prescribed in the standard.

Competent Person: One who is capable of identifying existing and predictable hazards in the surroundings or working conditions which are unsanitary, hazardous, or dangerous to employees, and who has authorization to take prompt corrective measures to eliminate them.

Qualified Person: A person with a recognized degree or professional certificate and with extensive knowledge, training, and experience in the fall protection and rescue field who is capable of designing, analyzing, evaluating and specifying fall protection and rescue systems to the extent required by the standard.

Rescuer: Person or persons other than the rescue subject acting to perform an assisted rescue by operation of a rescue system.

4. INSTALLATION AND OPERATION

4.1 General Installation Requirements: The winch is designed as a part of a confined space material handling system. The user must perform specific job hazard analysis in accordance with OSHA regulations. Mitigate hazards in accordance with OSHA guidelines.

4.2 Install the Winch Onto the Anchorage Structure: The winch is equipped with an integral bracket to attach it to the leg bracket on the anchorage structure. See FallTech manual number MCS07 for Tripods and MCS30 for Davit installation instructions regarding that portion of the bracket installed on the anchorage structure.

Place the winch bracket mating slots onto the mating rod on the structure leg bracket, align the top holes, and insert the detent pin, as shown in Figure 2A for an 8’ tripod, Figure 2B for an 11’ tripod and Figure 2C for a confined space davit.

4.3 Use of the Winch: Inspect the winch and cable before each use in accordance with the procedures in Section 7 of this manual. Ensure the cable is in proper working order, with no damage or deformities. See Figure 3A. Ensure the support structure is configured for maximum efficiency, and correctly oriented. The device should be at a comfortable height for use. Adjust device bracket if necessary. Reeve the cable onto the pulley. Ensure the material is secured to prevent objects and parts or pieces from falling during the hoisting and lowering process. Attach the winch leg end connector to the material. Rotate the crank handle counterclockwise to lower the material into a confined space and clockwise to raise the material from a confined space.

NOTE: Maintain 15 lbs of tension in both directions on the cable at all times to ensure proper functioning and to prevent bird nesting of the cable on the drum. See Figure 3B. When the crank handle stops turning, the internal friction brake will hold the load without crank rotation. If the winch exhibits signs of load slip or erratic functioning due to wear or overheating of the brake, remove the winch from service.

When hoisting, the winch will make a clicking sound. Ensure the cable lies evenly on the drum, with no over-lay. With a gear ratio of 5:1 and 15 lbs of force on the winch handle, a cranking rate of one revolution per second will yield a hoist rate of 12 ft/min. Ensure working lines are free of entanglement and contact with sharp edges.

5. SPECIFICATIONS

See Table 1.

6. MAINTENANCE AND STORAGE

Clean the unit with a mild detergent and water solution. Dry with suitable cloth.

Store in a cool place out of direct sunlight. Avoid chemical vapors and physical damage to the unit. Inspect after periods of prolonged storage.

Apply a thin coat of number 2 lithium grease to the winch gears occasionally.

Any repairs to the winch must be completed by the manufacture or a repair entity with written authorization to make repairs to this unit.

8. LABELS

The following labels must be present and legible.

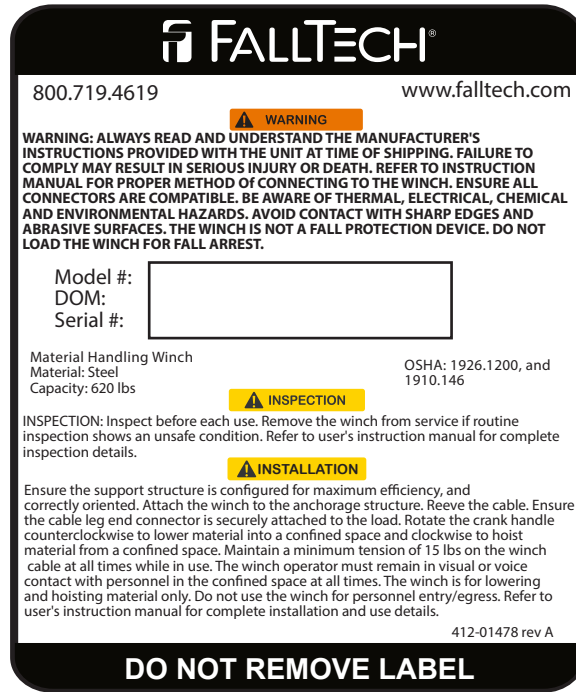

APPENDIX A

Table 1: Specifications for Material Winch					
Part #s & Length	Constituent and Tensile Strength	Winch Performance	Materials	Materials	Winch Capacity and Standards
<p>7293M 60ft</p> <p>7295M 120 ft</p>	<p>Wire Cable: Galvanized Steel 3/16" 7 x 19 Construction 3,400 lbs Minimum</p>	<p>Gear Ratio: 5 to 1</p> <p>Average Lifting Speed: 12ft per minute</p>	<p>Drive/Pinion Gear and Drum Gear: Alloy Steel</p> <p>Drum Gear Cover: Plastic</p>	<p>Swivel Snap Hook: Alloy Steel</p> <p>5,000 lbs Min Tensile Strength with 3,600 lbs Gate Strength</p> <p>Integral Bracket: Carbon Steel</p>	<p>620 lbs</p> <p>ANSI A10.5-1969</p> <p>OSHA 1926.502</p>

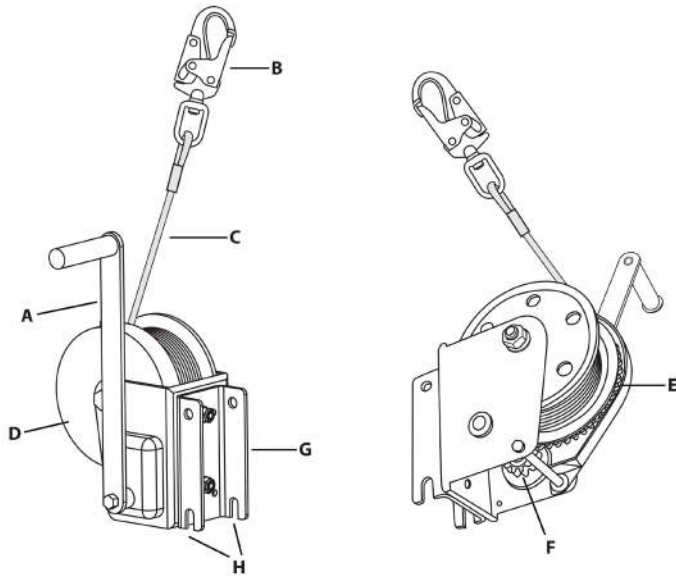

Figure 1: About Material Winch	
A	Winch Arm and Handle
B	Swivel Snap Hook
C	Wire Cable Winch Line
D	Drum Gear Cover
E	Drum Gear
F	Drive/Pinion Gear
G	Integral Bracket
H	Bracket Mating Slots for Tripod

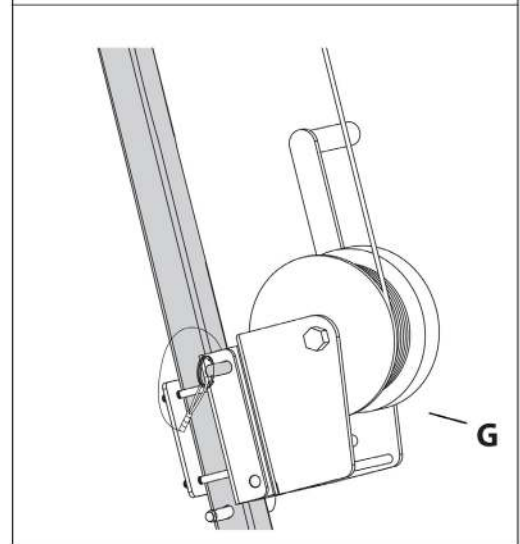
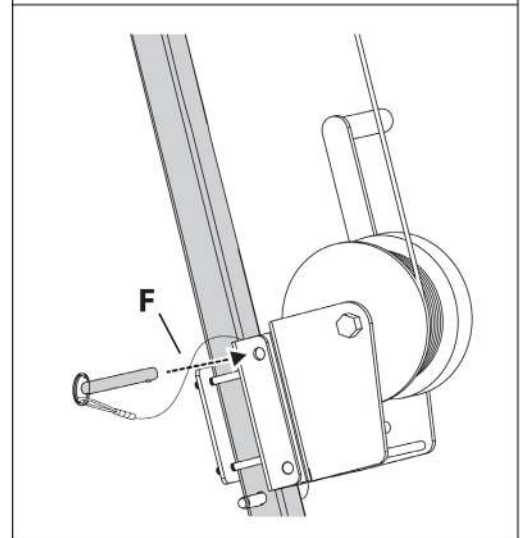
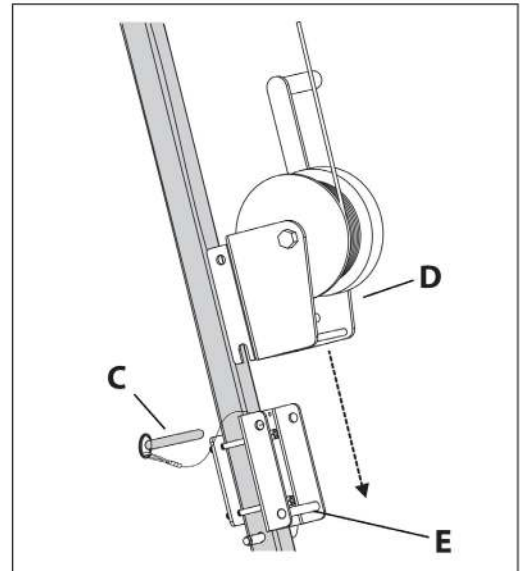
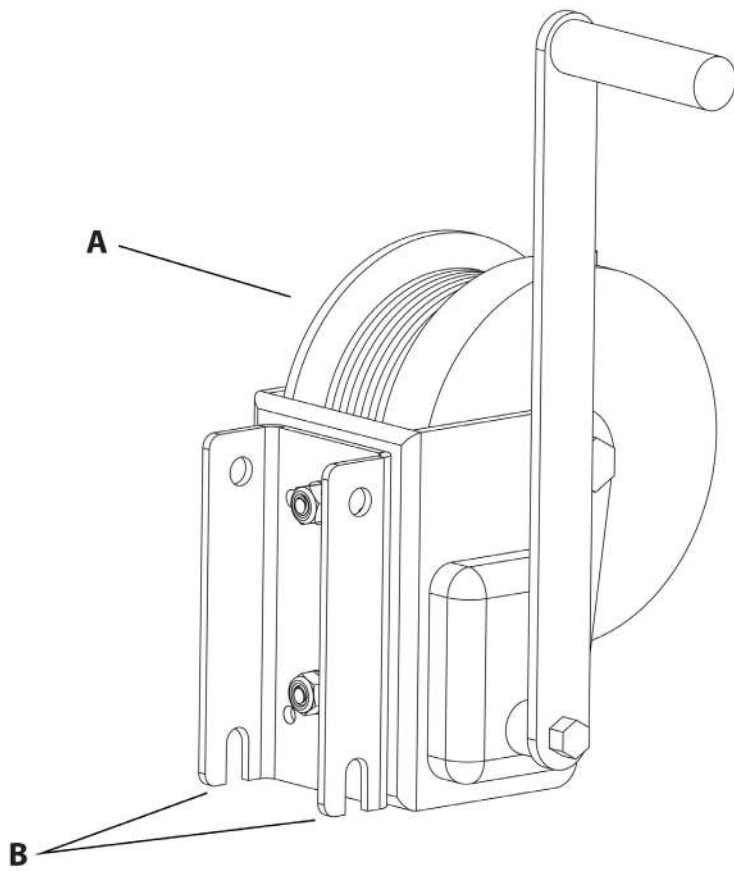

Figure 2A: Attach Winch to 8ft Tripod Leg Bracket

A	Winch with Integral Mounting Bracket
B	Mating Slots for Tripod Leg Bracket Attachment
C	Integral Device Securing Detent Pin
D	Align Mating Slots to Engage Leg Bracket Rod
E	Leg Bracket Rod
F	Insert Detent Pin through Winch and Leg Brackets
G	Winch Secured to Leg Bracket

#7291B Leg Bracket shown in Figure 2A

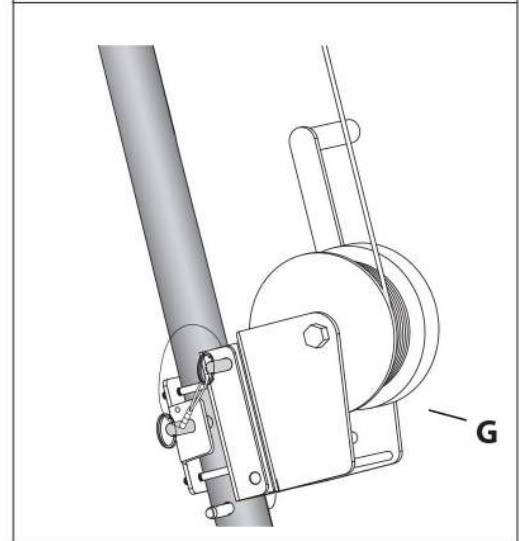
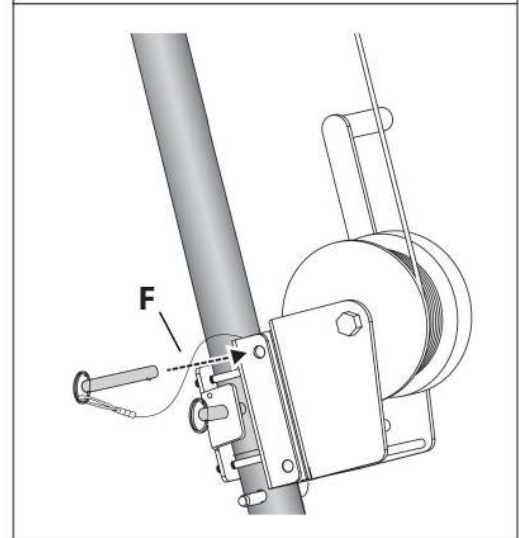
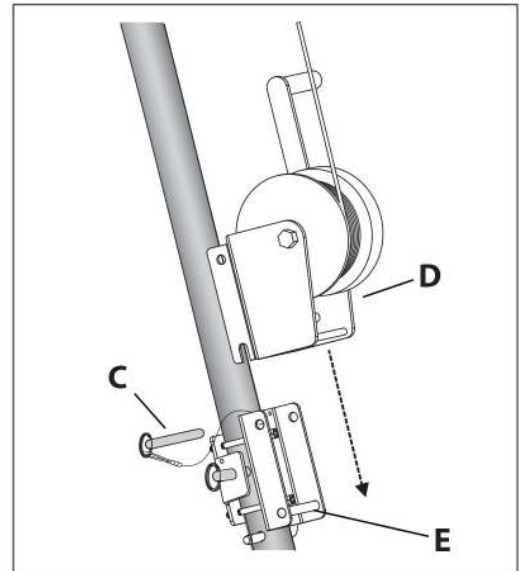
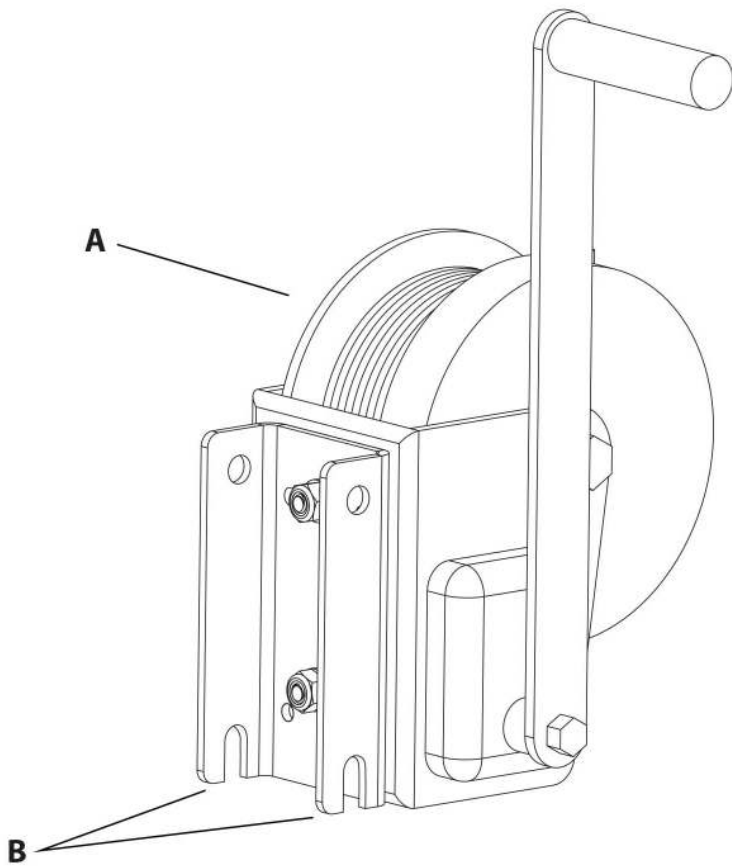

Figure 2B: Attach Winch to 11 ft Tripod Leg Bracket

A	Winch with Integral Mounting Bracket
B	Mating Slots for Tripod Leg Bracket Attachment
C	Integral Device Securing Detent Pin
D	Align Mating Slots to Engage Leg Bracket Rod
E	Leg Bracket Rod
F	Insert Detent Pin through Winch and Leg Brackets
G	Winch Secured to Leg Bracket

#7291A Leg Bracket shown in Figure 2B

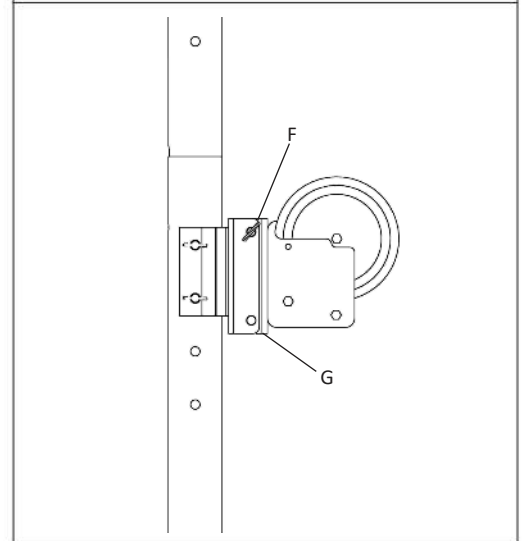
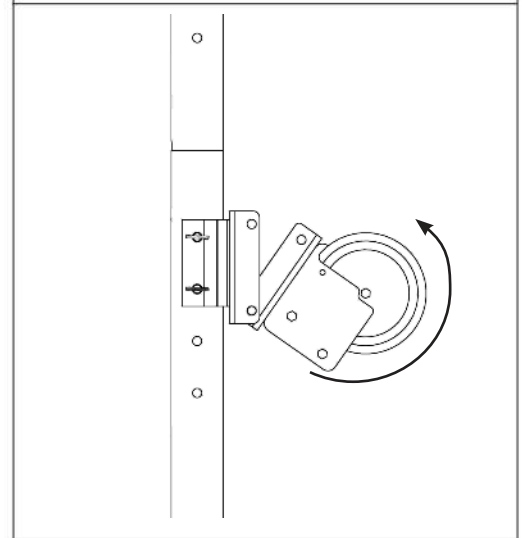
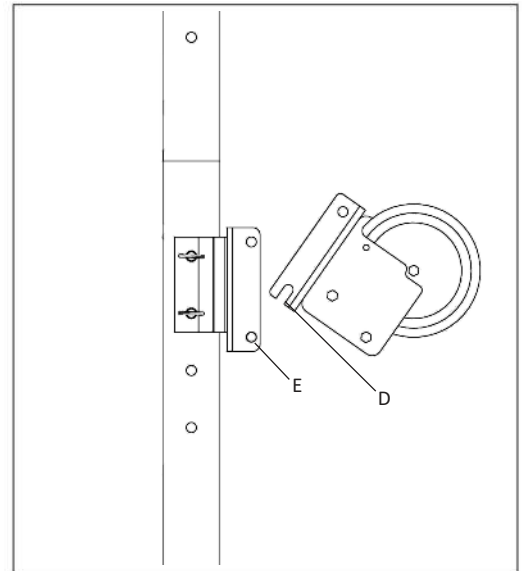
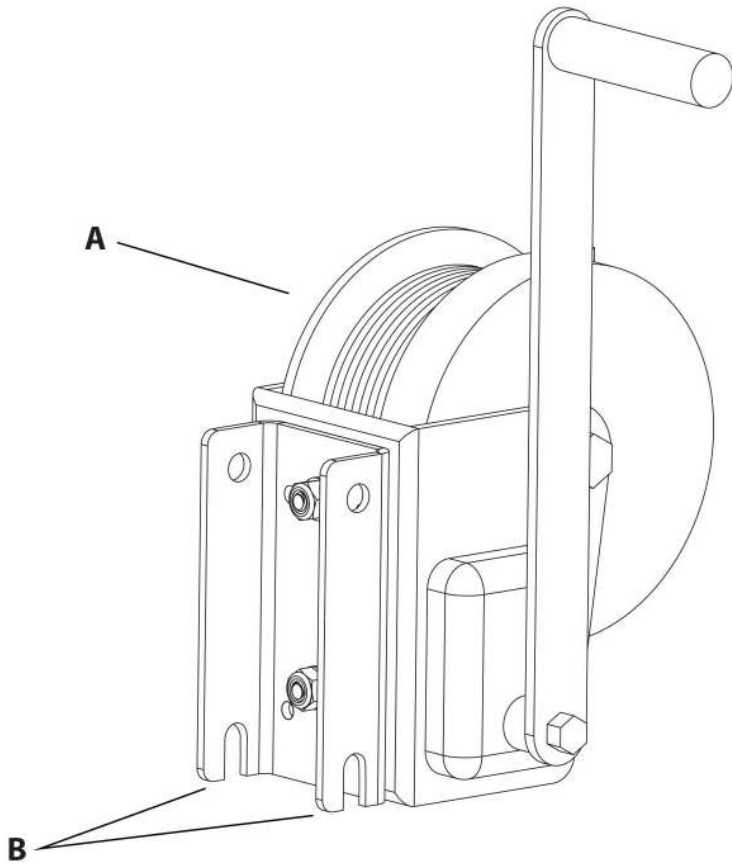

Figure 2C: Attach Winch to Davit

A	Winch with Integral Mounting Bracket
B	Mating Slots for Davit Bracket Attachment
C	Integral Device Securing Detent Pin
D	Align Mating Slots to Engage Davit Bracket (not shown)
E	Davit Bracket Rod
F	Insert Detent Pin through Winch and Davit Brackets
G	Winch Secured to Davit Bracket

#65101DU Leg Bracket shown in Figure 2C

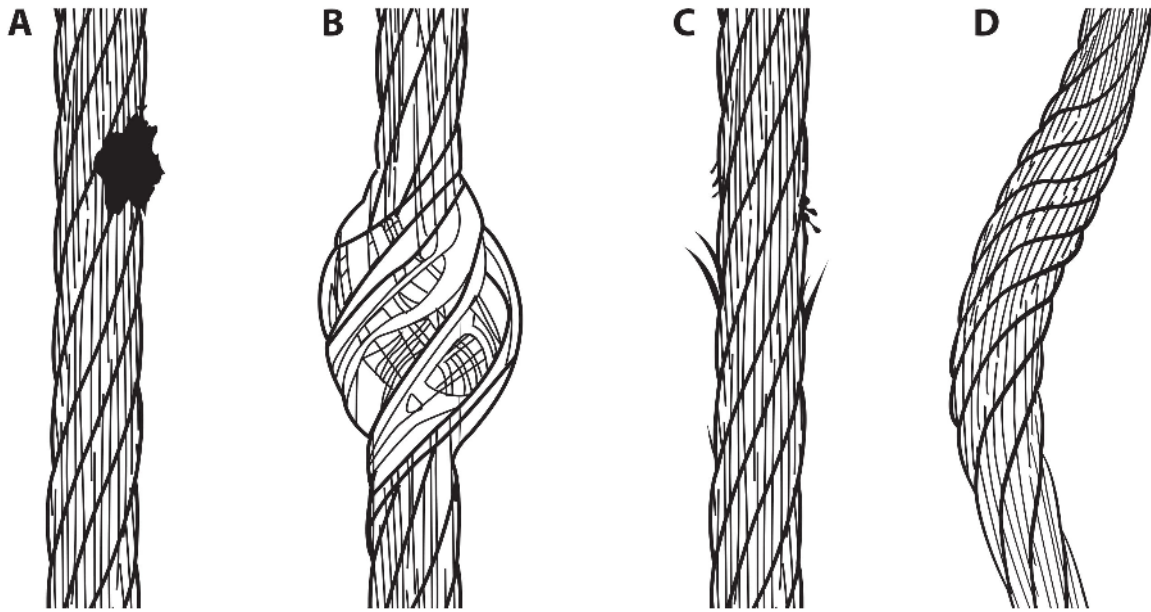

Figure 3A: Inspection of Constituent Cable

A	Heat Damage from Weld Spatter or Slag
B	Bird Caged
C	Broken Wires within Strands
D	Curled, Bent or Kinked

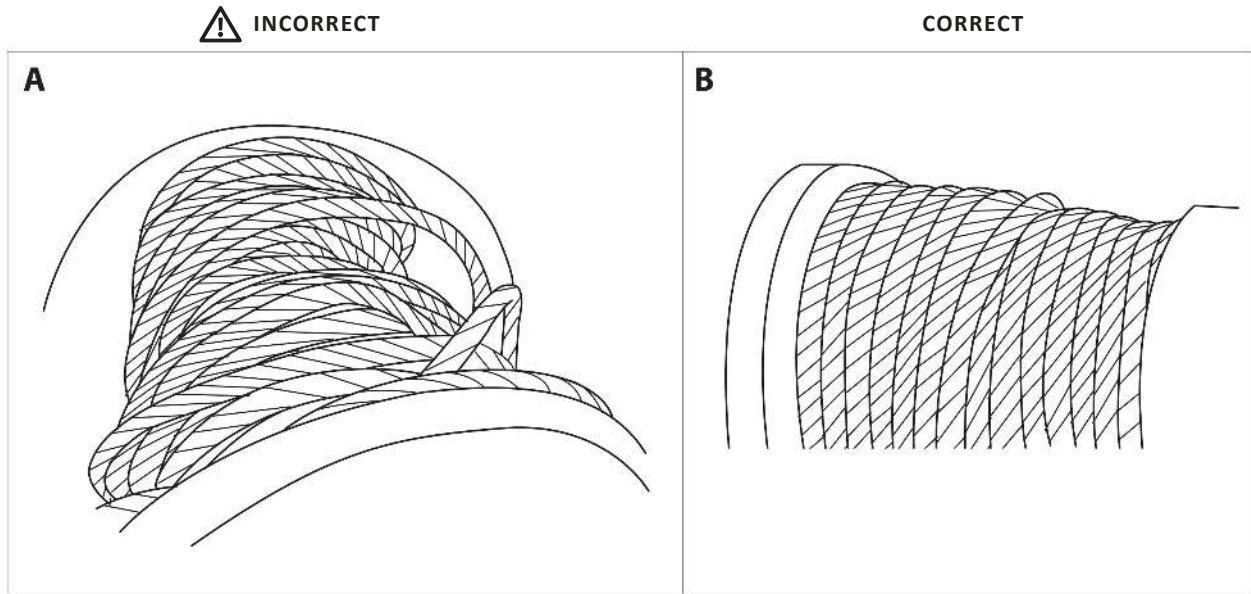

Figure 3B: Incorrect and Correct Cable Placement

A	Incorrect- Avoid Bird's Nesting of Cable
B	Correct- Even Cable Placement