

Confined Space Personnel Winch

User Instruction Manual

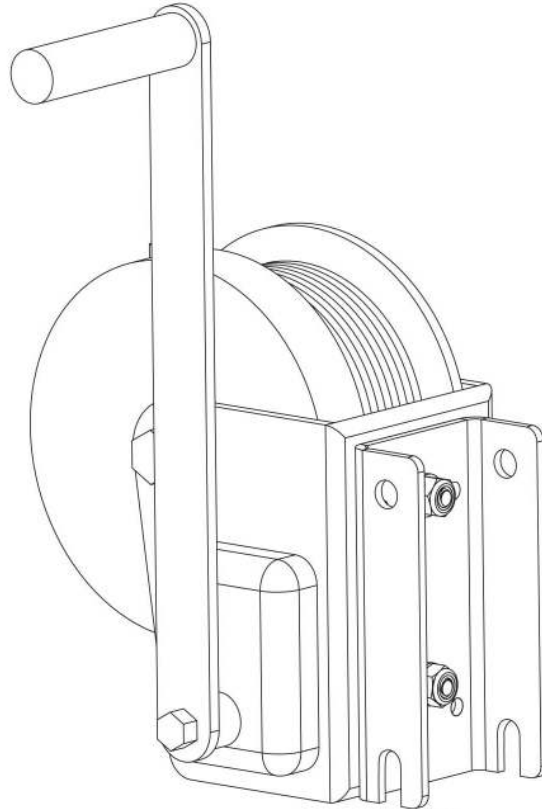

This manual is intended to meet the Manufacturer's Instructions as required by the American National Standards Institute(ANSI) Z359.4-2013, Z117.1-2009, A10.32-2012, and Occupational Safety and Health Administration (OSHA) regulations 1926.502, 1926.1200, and 1910.146 and should be used as part of an employee training program as required by OSHA. The user of the equipment discussed in this manual must read and understand this manual, or have it explained to them, before beginning work. This manual assumes the user has been trained in the use of this equipment in a Non-Permit and Permit Required Confined Space environment.

WARNING

- Avoid moving machinery, thermal, electrical and/or chemical hazards as contact may cause serious injury or death.
- Avoid swing falls.
- Follow the weight restrictions and recommendations in this manual.
- Remove from service any equipment subjected to fall arrest forces.
- Remove from service any equipment that fails inspection.
- Do not alter or intentionally misuse this equipment.
- Consult FallTech when using this equipment in combination with components or subsystems other than those described in this manual.
- Do not connect rebar hooks, large carabiners, or large snap hooks to the FBH dorsal D-rings as this may cause a roll-out condition and/or unintentional disengagement.
- Avoid sharp and/or abrasive surfaces and edges.
- Use caution when performing arc welding. Arc flash from arc welding operations, including accidental arcs from electrical equipment, can damage equipment and are potentially fatal.
- Examine the work area. Be aware of the surroundings and workplace hazards that may impact safety, security, and the functioning of fall arrest systems and components.
- Hazards may include but not be limited to cable or debris tripping hazards, equipment failures, personnel mistakes, moving equipment such as carts, barrows, fork lifts, cranes, or dollies. Do not allow materials, tools or equipment in transit to contact any part of the fall arrest system.
- Do not work under suspended loads.

IMPORTANT

This product is part of a personal fall arrest, restraint, work positioning, suspension, or rescue system. A Personal Fall Arrest System (PFAS) is typically composed of an anchorage and a Full Body Harness (FBH), with a connecting device, i.e., a Shock Absorbing Lanyard (SAL), or a Self-Retracting Device (SRD), attached to the dorsal D-ring of the FBH.

These instructions must be provided to the worker using this equipment. The worker must read and understand the manufacturer's instructions for each component or part of the complete system. Manufacturer's instructions must be followed for proper use, care, and maintenance of this product. These instructions must be retained and be kept available for the worker's reference at all times. Alterations or misuse of this product, or failure to follow instructions, may result in serious injury or death.

A Fall Protection Plan must be on file and available for review by all workers. It is the responsibility of the worker and the purchaser of this equipment to assure that users of this equipment are properly trained in its use, maintenance, and storage. Training must be repeated at regular intervals. Training must not subject the trainee to fall hazards.

Consult a doctor if there is reason to doubt your fitness to safely absorb the shock of a fall event. Age and fitness seriously affect a worker's ability to withstand falls. Pregnant women or minors must not use this equipment.

ANSI limits the weight of fall protection equipment users to a maximum of 310 lbs. Products in this manual may have a rated capacity exceeding ANSI capacity limits. Heavy users experience more risk of serious injury or death due to falls because of increased fall arrest forces placed on the user's body. In addition, the onset of suspension trauma after a fall even may be accelerated for heavy users.

The user of the equipment discussed in this manual must read and understand the entire manual before beginning work.

NOTE: For more information consult the ANSI Z359 body of standards.

Table of Contents

1. DESCRIPTION	
1.1 American National Standards Institute (ANSI) and Occupational Safety and Health Administration (OSHA)	
2. APPLICATION	
2.1 Purpose	
2.2 Application Limits	
3. SYSTEM REQUIREMENTS	
3.1 Capacity	
3.2 Compatibility Of Connectors	
3.3 Compatibility Of Components	
3.4 Making Connections	
3.5 Personal Fall Arrest System	
3.5.1 PFAS Anchorage Strength	
	3.5.2 Work Positioning
	3.5.3 Personnel Riding
	3.5.4 Rescue
	3.6 Definitions
4. INSTALLATION AND OPERATION	
4.1 General Installation Requirements	
4.2 Install The Winch Onto The Anchorage Structure	
4.3 Use The Winch	
5. SPECIFICATIONS	
6. MAINTENANCE AND STORAGE	
7. INSPECTION OF WINCH	
8. LABELS	
Appendix A	
Appendix C	

1. DESCRIPTION

The FallTech® Confined Space Personnel Winch is primarily for those entering and working in confined spaces, both permit and non-permit, and is to be used as part of a restraint, work positioning, suspension, or rescue system in a complete confined space system. See Section 3 and Appendix C of this manual.

The Personnel Winch is composed of a steel frame, gears, shaft and winch handle, with stainless steel or galvanized wire rope cable. The frame is bolted to a mating bracket to facilitate installation onto an anchorage structure such as a tripod or davit. This manual contains two Appendices; A and C. Appendix A contains figures and tables specific to the winch discussed in this manual. Appendix C contains general information, installation and use procedures for confined space equipment. All figures, tables and chart references in this manual are to Appendix A unless otherwise noted.

For purposes of this manual, the FallTech® Confined Space Personnel Winch, in all iterations, may be referred to collectively as the personnel winch, the equipment, the product, or the unit. See Table 1 for products, materials, specifications and ratings. See Figure 1 for an illustration of the product parts and features.

1.1 American National Standards Institute (ANSI) and Occupational Safety and Health Administration (OSHA): The winch discussed in this manual, including all devices attached to it, meets the standards of ANSI Z359.4-2013, Z117.1-2009, A10.32-2012, and Occupational Safety and Health Administration (OSHA) regulations for general industry 1926.502, 1910.146, and 1926.1200 for construction. OSHA requires all employees working in a confined space application be trained regarding the nature of hazards involved, the necessary precautions to be taken, and in the use of protective and emergency equipment.

2. APPLICATION

2.1 Purpose: A typical confined space application is a support structure set up over an entry point, equipped with a confined space access system. The winch discussed in this manual is part of a system to help facilitate non-entry rescue and entry rescue from confined spaces, including work positioning and personnel riding. See Appendix C of this manual.

The winch operator directs the cable and maintains constant contact with the entrant, either visually or by other means.

The entrant in the confined space is equipped with an approved full body harness and remains attached to a lifeline.

2.2 Application Limits: Take action to avoid sharp edges, rough, abrasive or corroded surfaces and edges, and thermal, electrical and chemical hazards. Ensure the winch is properly attached to a support structure as specified in this manual.

When used with a FallTech anchorage structure, the winch is rated for one worker weighing a minimum of 130 lbs to a maximum of 310 lbs (including all clothing, tools, and equipment).

NOTE: The winch discussed in this manual is not intended for material handling applications. The material handling winch is discussed in FallTech User Instruction Manual MCS09.

3. SYSTEM REQUIREMENTS

3.1 Capacity: The capacity of the winch is one worker between 130 lbs to 310 lbs. (140 kg) including tools, clothing, etc.

3.2 Compatibility Of Connectors: Connectors are considered compatible with connecting elements when they have been designed to work together in such a way that their sizes and shapes do not cause their gate mechanisms to open inadvertently, regardless of how they become oriented. Contact FallTech if you have any questions about compatibility. Connectors must be compatible with the anchorage or other system components. Do not use equipment that is not compatible. Non-compatible connectors may unintentionally disengage. Connectors must be compatible in size, shape, and strength. Self-closing, self-locking snap hooks and carabiners are required by OSHA.

3.3 Compatibility Of Components: Equipment is designed for use with approved components and subsystems only. Substitutions or replacements made with non-approved components or subsystems may jeopardize compatibility of equipment and may affect the safety and reliability of the complete system.

3.4 Making Connections: Only use self-locking snap hooks and carabiners with this equipment. Only use connectors that are suitable to each application. Ensure all connections are compatible in size, shape and strength. Do not use equipment that is not compatible. Visually ensure all connectors are fully closed and locked. Connectors (snap hooks and carabiners) are designed for use only as specified in the user instruction manual provided with each product.

DO NOT use rebar hooks or any large-throat opening hooks with this winch.

3.5 Personal Fall Arrest System: The additional PFAS components used with this equipment must meet applicable OSHA requirements. A FBH must be worn when this equipment is used as a component of a PFAS. As required by OSHA, the personal fall protection system must be able to arrest the user's fall with a maximum arresting force of 1,800 lbs., and limit the free fall to 6 feet or less. If the maximum free fall distance must be exceeded, the employer must document, based on test data, that the maximum arresting force will not be exceeded, and the personal fall protection system will function properly.

3.5.1 PFAS Anchorage Strength: The winch shown in Table 1 is listed as having a minimum tensile strength of 5,000 lbs. To maintain OSHA compliance, the structure where the unit is installed must be capable of supporting at least 5,000 lbs, or be designed, installed and used as part of a PFAS, which maintains a safety factor of at least 2:1, under the supervision of a qualified person.

3.5.2 Work Positioning: Work positioning requires an anchorage capable of supporting 5,000 lbs applied in the direction permitted by the system.

3.5.3 Personnel Riding: A structure used for personnel riding, lowering and hoisting must be able to support a static load of 2,500 lbs applied in the direction permitted by the system.

3.5.4 Rescue: A structure used for rescue must be able to support a static load of 2,500 lbs applied in the direction permitted by the system.

3.6 Definitions: The following are definitions of terms as defined in ANSI Z359.0-2012.

Authorized Person: A person assigned by the employer to perform duties at a location where the person will be exposed to a fall hazard (otherwise referred to as "user" for the purpose of these instructions).

Certified Anchorage: An anchorage for fall protection, positioning, restraint, or rescue systems that a qualified person certifies to be capable of supporting the potential fall forces that could be encountered during a fall or that meet the criteria for a certified anchorage prescribed in the standard.

Competent Person: One who is capable of identifying existing and predictable hazards in the surroundings or working conditions which are unsanitary, hazardous, or dangerous to employees, and who has authorization to take prompt corrective measures to eliminate them.

Qualified Person: A person with a recognized degree or professional certificate and with extensive knowledge, training, and experience in the fall protection and rescue field who is capable of designing, analyzing, evaluating and specifying fall protection and rescue systems to the extent required by the standard.

Rescuer: Person or persons other than the rescue subject acting to perform an assisted rescue by operation of a rescue system.

4. INSTALLATION AND OPERATION

4.1 General Installation Requirements: The winch is designed as a part of a confined space system. The user must perform specific job hazard analysis in accordance with OSHA regulations. Mitigate hazards in accordance with OSHA guidelines.

4.2 Install the Winch Onto the Anchorage Structure: The winch is equipped with an integral bracket to attach it to the leg bracket on the anchorage structure. See FallTech manual number MCS07 for Tripods and MCS30 for Davit installation instructions regarding that portion of the bracket installed on the anchorage structure.

Place the winch bracket mating slots onto the mating rod on the structure leg bracket, align the top holes, and insert the detent pin, as shown in Figure 2A for an 8' tripod, Figure 2B for an 11' tripod and Figure 2C for a confined space davit.

4.3 Use of the Winch: Inspect the winch and cable before each use in accordance with the procedures in Section 7 of this manual. Ensure the cable is in proper working order, with no damage or deformities. See Figure 3A. Ensure the support structure is configured for maximum efficiency, and correctly oriented. The device should be at a comfortable height for use. Adjust device bracket if necessary. For more information see instruction manuals MCS07 for tripods or MCS30 for the davit.

Attach the winch leg end connector to the entrant's dorsal D-ring of the full body harness.

To raise a load, rotate the winch handle in the clockwise direction.

To suspend a load, release the handle and the brake will suspend the load until further action is needed. Do not exceed the rated capacity of 310lbs.

To lower a load, rotate the crank handle counterclockwise to lower the entrant into a confined space. The handle will rotate approximately one revolution before the load starts to lower. If the secondary brake is engaged, raise the load approximately one turn of the drum before attempting to lower the load.

NOTE: Maintain 15 lbs of tension in both directions on the cable at all times to ensure proper functioning and to prevent bird nesting of the cable on the drum. See Figure 3B. The entrant must ascend and descend from the confined space at a consistent, even pace. The attendant must remain in visual or voice contact with the entrant at all times.

When the crank handle stops turning, the internal friction brake will hold the load without crank rotation. If the winch exhibits signs of load slip or erratic functioning due to wear or overheating of the brake, remove the winch from service.

When hoisting, the winch will make a clicking sound. Ensure the cable lies evenly on the drum, with no over-lay. With a gear ratio of 5:1, 15 lbs of force on the winch handle, at a cranking rate of one revolution per second, will yield a hoist rate of 12 ft/min.

Ensure working lines are free of entanglement and contact with sharp edges. The winch is not a fall protection device and must not be subjected to fall arrest forces.

Use of the winch for suspension or personnel riding requires a back-up fall protection system, see Appendix C.

For additional information on confined space, see Appendix C of this manual.

5. SPECIFICATIONS

See Table 1.

6. MAINTENANCE AND STORAGE

Clean the unit with a mild detergent and water solution. Dry with suitable cloth.

Store in a cool place out of direct sunlight. Avoid chemical vapors and physical damage to the unit. Inspect after periods of prolonged storage.

Apply a thin coat of number 2 lithium grease to the winch gears occasionally.

Any repairs to the winch must be completed by the manufacture or a repair entity with written authorization to make repairs to this unit. Return the winch to the manufacturer every two years for service.

7. GENERAL INSPECTION OF THE PERSONNEL WINCH

Prior to each use, inspect the entire unit, including the leg end connector, for signs of corrosion, cracks, deformities and broken or missing parts. Inspect the wire rope for cuts, abrasions, weld spatter, arc damage, fishhooks, broken strands, kinks, birdcaging, anytype of debris, as shown in Figure 3A.

A thorough inspection of the wire rope should be made at least once a month. This is performed by unreeling of all the wire rope from the winch. Using gloves, inspect the entire working length for cuts, abrasions, weld spatter, arc damage, fishhooks, broken strands, kinks, birdcages, any type of debris, as shown in Figure 3.

Rewind the cable onto the drum, in accordance with the procedures in this manual. If the cable bird nests or over rides onto itself, crank the cable out, remedy the cause, and rewind the cable.

Inspect the labels to be sure they are present and legible.

An inspection by a competent person other than the user is required every six months in accordance with the procedures in this manual. If routine inspection reveals an unsafe condition, remove it from service.

Record the results of each inspection on the Inspection Log provided or in another suitable place.

INSPECTION RECORD PLANILLA de INSPECCIÓN					
Model # Modelo N° : _____			Serial # N° de serie : _____		
Date of Manufacture Fecha de fabricación : _____					
Inspection Date Fecha de inspección	Inspector Inspector	Comments Observaciones	Pass/Fail Pasó/No pasó	Corrective Action Needed Accion correctiva a realizar	Approved By Aprobado por

8. LABELS

The following labels must be present and legible.

FALLTECH®

Personnel Winch

800.719.4619 www.falltech.com

Maximum Working Length: <input type="checkbox"/> 60' <input type="checkbox"/> 120'	Capacity of Winch: 130 lbs to 310 lbs (including clothing, tools, etc.)
---	--

⚠ WARNING ALWAYS READ AND UNDERSTAND THE MANUFACTURER'S INSTRUCTIONS PROVIDED WITH THE UNIT AT THE TIME OF SHIPPING. FAILURE TO COMPLY MAY RESULT IN SERIOUS INJURY OR DEATH. REFER TO INSTRUCTION MANUAL FOR PROPER METHOD OF CONNECTING TO THE WINCH. ENSURE ALL CONNECTORS ARE COMPATIBLE. BE AWARE OF THERMAL, ELECTRICAL, CHEMICAL AND ENVIRONMENTAL HAZARDS. AVOID CONTACT WITH SHARP EDGES AND ABRASIVE SURFACES.

Model#: _____ Date of Mfr: _____ Serial #: _____	ANSI Z359.4-2013, Z117.1-2009, OSHA 1926.502, 1926.1200 and 1910.146
--	---

Cable Construction: 3/16" Diameter
 Galvanized Steel
 Stainless Steel

412-01338 Rev A

DO NOT REMOVE LABEL

FALLTECH®

⚠ INSPECTION Inspect at least annually. Inspect before each use. Remove the winch from service if routine inspection shows an unsafe condition. Refer to user's instruction manual for complete inspection details.

⚠ INSTALLATION Ensure the support structure is configured for maximum efficiency and correctly oriented. Attach the winch to the anchorage structure. Reeve the cable by slowly pulling out the winch line and lace over the support structure pulley. Rotate the handle counter-clockwise to lower the entrant into a confined space. And clockwise to hoist the entrant from a confined space. Attach the cable end connector to entrant's Full Body Harness to the D-ring appropriate for the application. The confined space entrant must ascend and descend from the confined space at a consistent, even pace. Maintain a minimum tension of 15 lbs on the winch cable at all times while in use. Force of 30 lbs is required to operate rescue features when the device is loaded to maximum capacity. The attendant must remain in visual or voice contact with the entrant at all times. The winch is for lowering and hoisting personnel only. Do not use the winch for material handling. Refer to user's instruction manual for complete installation and use details.

60

412-01339 Rev A

DO NOT REMOVE LABEL

APPENDIX A

Table 1: Specifications for Personnel Winch				
Part #s & Length	Constituent and Tensile Strength	Winch Performance	Materials	Winch Capacity and Standards
<p>7297 60ft</p> <p>7298 120ft</p>	<p>Wire Cable: Galvanized Steel</p> <p style="text-align: center;">3/16" 7 x 19 Construction</p> <p style="text-align: center;">3,400 lbs Minimum</p>	<p>Gear Ratio: 5 to 1</p>	<p>Drive/Pinion Gear and Drum Gear: Alloy Steel</p> <p>Drum Gear Cover: Plastic</p> <p>Swivel Snap Hook: Alloy Steel</p> <p>5,000 lbs Min Tensile Strength with 3,600 lbs Gate Strength</p> <p>Integral Bracket: Carbon Steel</p>	<p style="text-align: center;">130 to 310 lbs</p> <p style="text-align: center;">ANSI Z359.4-2013 Z117.1-2009 A10.32-2012</p> <p style="text-align: center;">OSHA 1926.502 1926.1200 1926.146</p>
<p>7297S 60ft</p> <p>7298S 120ft</p>	<p>Wire Cable: Stainless Steel Cable</p> <p style="text-align: center;">3/16" 7 x 19 Construction</p> <p style="text-align: center;">3,400 lbs Minimum</p>	<p>Average Lifting Speed: 12ft per minute</p>	<p>5,000 lbs Min Tensile Strength with 3,600 lbs Gate Strength</p>	

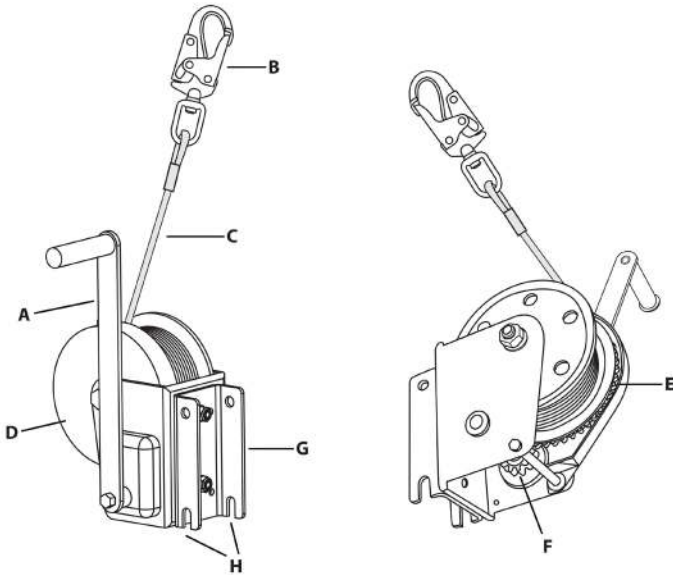

Figure 1: About Personnel Winch	
A	Winch Arm and Handle
B	Swivel Snap Hook
C	Wire Cable Winch Line
D	Drum Gear Cover
E	Drum Gear
F	Drive/Pinion Gear
G	Integral Bracket
H	Bracket Mating Slots for Tripod

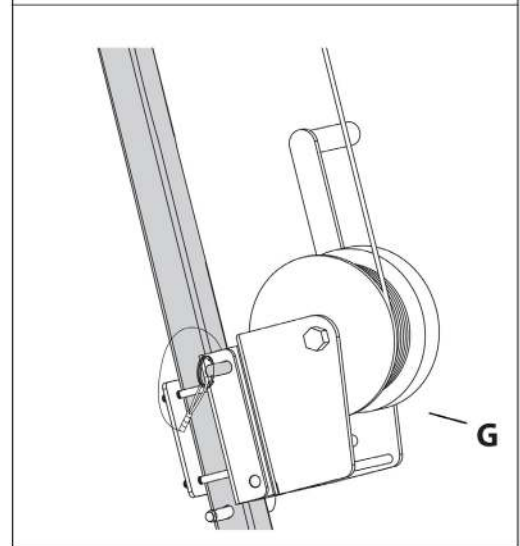
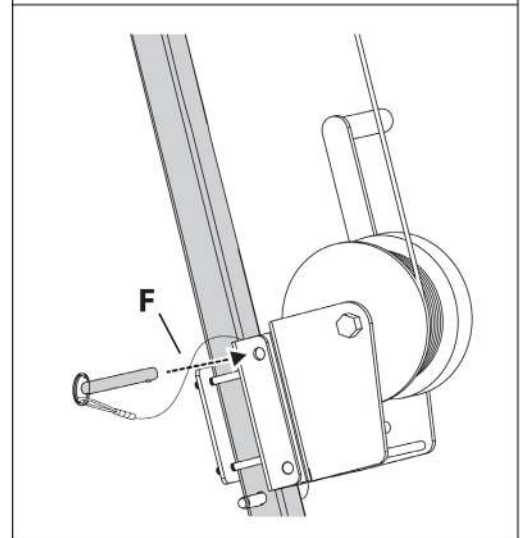
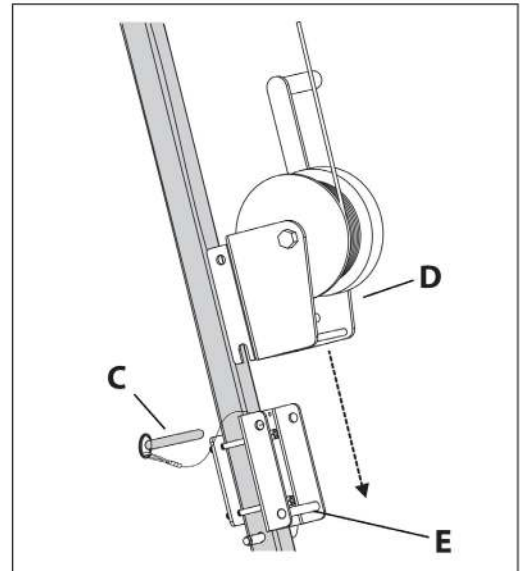
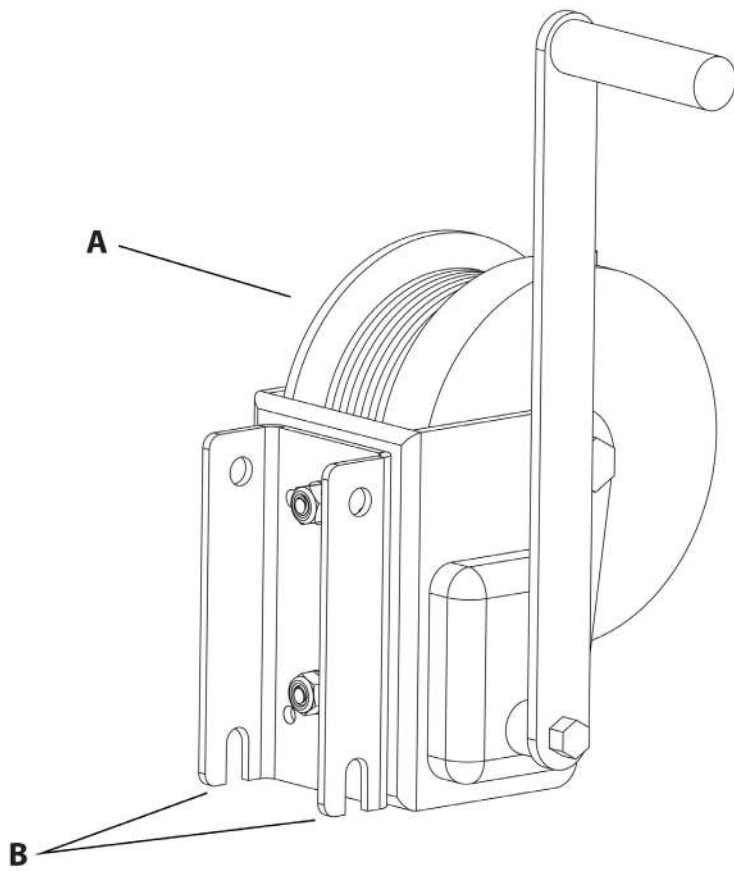

Figure 2A: Attach Winch to 8ft Tripod Leg Bracket

A	Winch with Integral Mounting Bracket
B	Mating Slots for Tripod Leg Bracket Attachment
C	Integral Device Securing Detent Pin
D	Align Mating Slots to Engage Leg Bracket Rod
E	Leg Bracket Rod
F	Insert Detent Pin through Winch and Leg Brackets
G	Winch Secured to Leg Bracket

#7291B Leg Bracket shown in Figure 2A

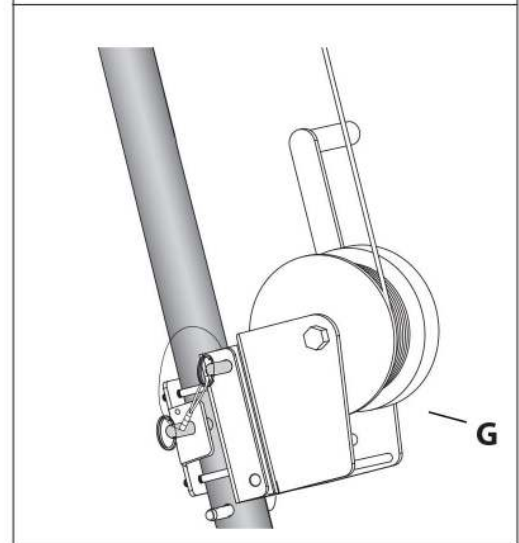
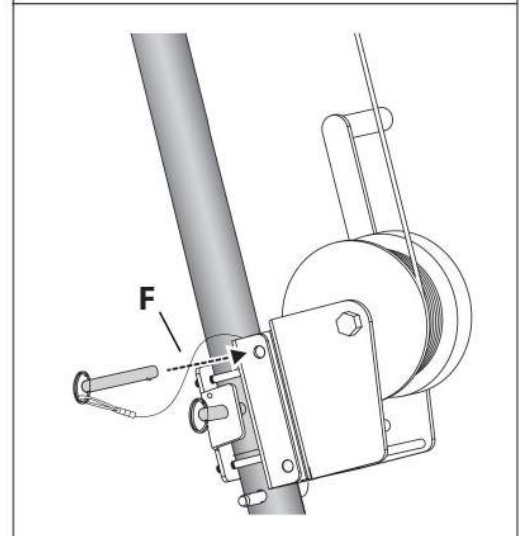
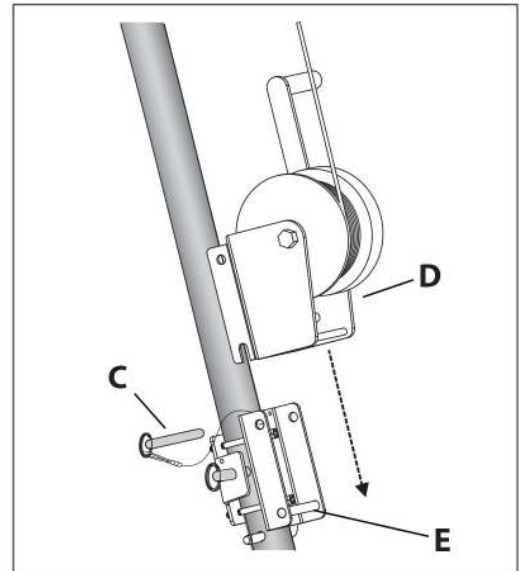
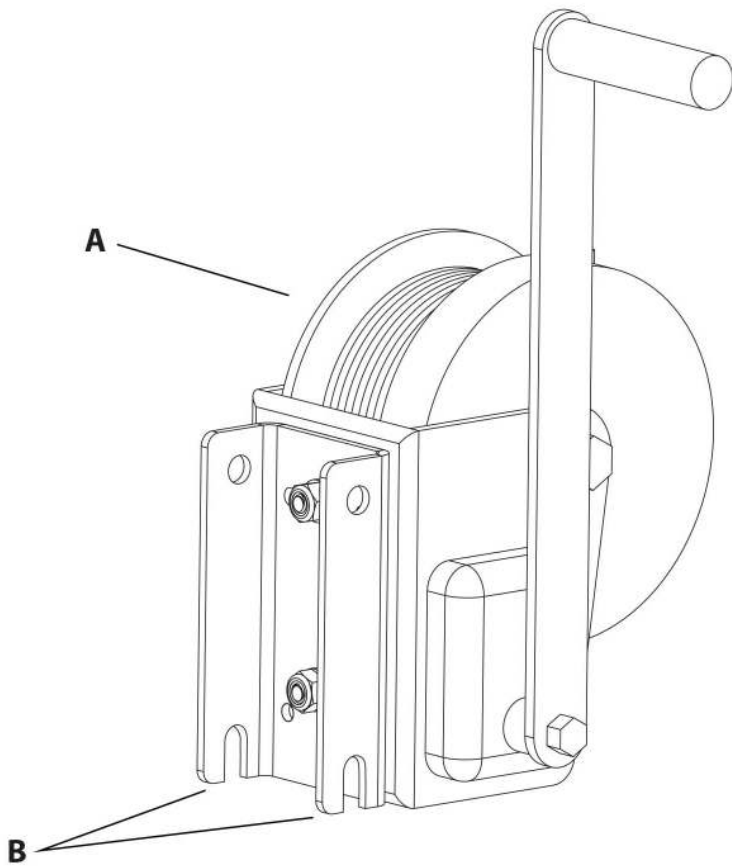

Figure 2B: Attach Winch to 11 ft Tripod Leg Bracket

A	Winch with Integral Mounting Bracket
B	Mating Slots for Tripod Leg Bracket Attachment
C	Integral Device Securing Detent Pin
D	Align Mating Slots to Engage Leg Bracket Rod
E	Leg Bracket Rod
F	Insert Detent Pin through Winch and Leg Brackets
G	Winch Secured to Leg Bracket

#7291A Leg Bracket shown in Figure 2B

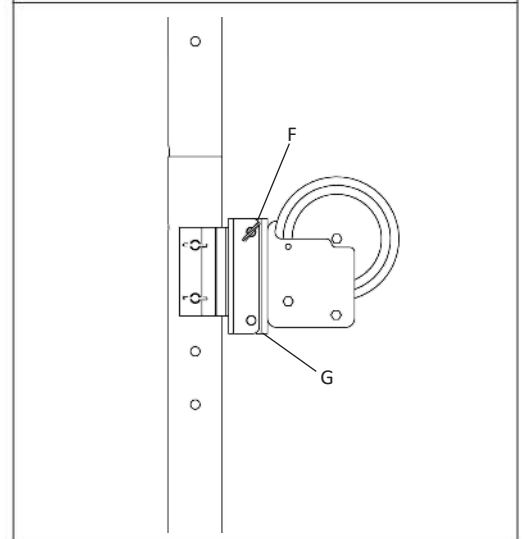
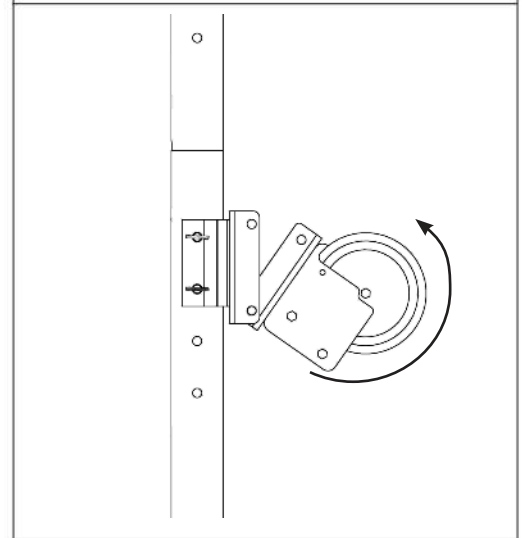
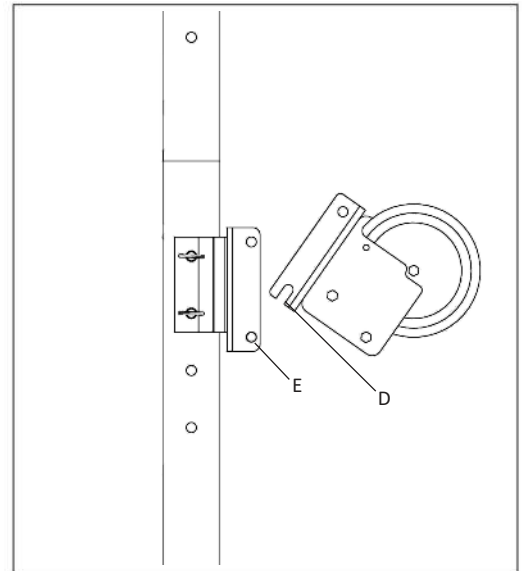
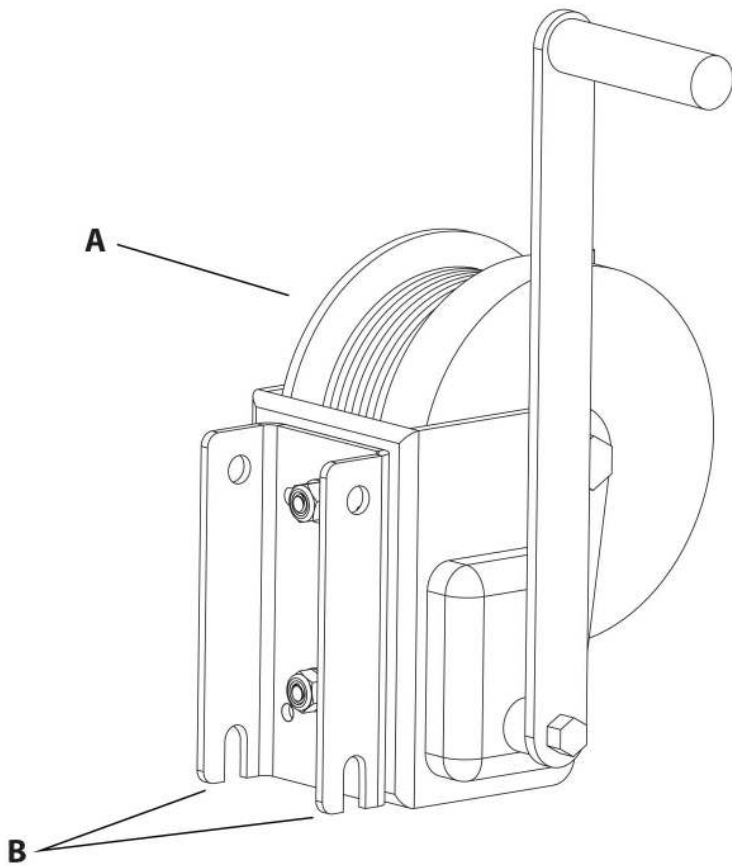

Figure 2C: Attach Winch to Davit

A	Winch with Integral Mounting Bracket
B	Mating Slots for Davit Bracket Attachment
C	Integral Device Securing Detent Pin
D	Align Mating Slots to Engage Davit Bracket
E	Davit Bracket Rod
F	Insert Detent Pin through Winch and Davit Brackets
G	Winch Secured to Davit Bracket

#65101DU Leg Bracket shown in Figure 2C

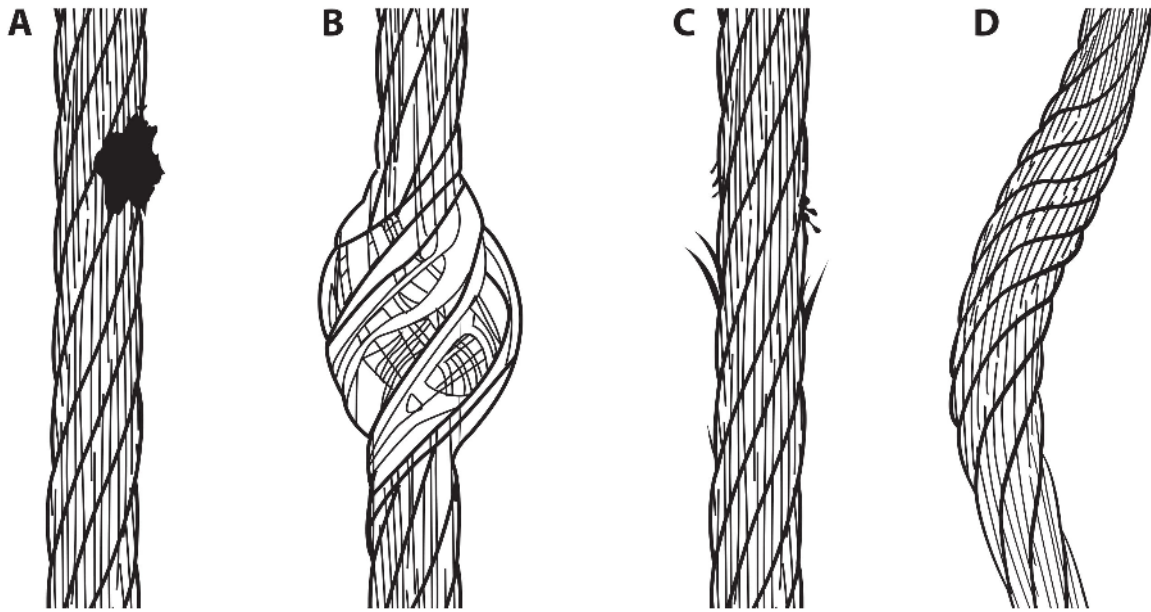

Figure 3A: Inspection of Constituent Cable

A	Heat Damage from Weld Spatter or Slag
B	Bird Caged
C	Broken Wires within Strands
D	Curled, Bent or Kinked

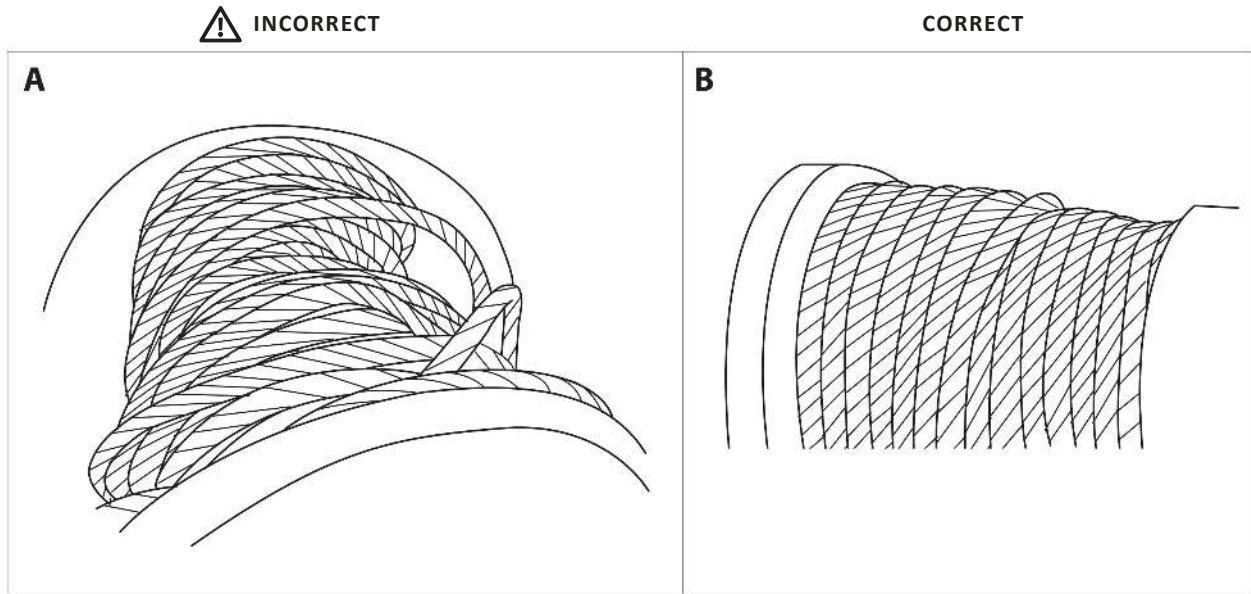

Figure 3B: Incorrect and Correct Cable Placement

A	Incorrect- Avoid Bird's Nesting of Cable
B	Correct- Even Cable Placement

APPENDIX C

Considerations for Rescue from a Permit-Required Confined Space

General Rescue Requirements

The equipment specified in this manual is designed to work as part of a system to help facilitate non-entry rescue and entry rescue from confined spaces.

Confined spaces vary in size, shape, configuration and hazard, and the equipment/device(s) detailed in this manual may not be suitable for use during some permit-required confined space entries. Hazards such as entanglement, electric arc, engulfment, and general lift obstructions may interfere with safe rescue and cause greater harm to the entrant.

All confined space entries should be planned whenever possible in such a manner that any foreseeable hazard is mitigated and non-entry rescue can be facilitated.

In the case that non-entry rescue is not feasible a rescue plan must be in place that provides rescuers with knowledge about the specific confined space hazards they may encounter during a rescue, training on appropriate rescue methods for the confined space they will be entering and the correct equipment and PPE to perform the entry rescue. Please reference OSHA code CFR 1926.1211 for further details on employer responsibilities in preparing for both entry and non-entry rescue.

System Configurations for Non-Entry Rescue Methods

When entering a permit-required confined space non-entry rescue is required unless retrieval equipment would increase the overall risk of entry or would not contribute to the rescue of the worker. Mechanical devices must be available to retrieve personnel from vertical type permit spaces more than 5 feet deep. When using mechanical devices for non-entry rescue, consideration must be given to the means of entry/egress, the mitigation of fall hazards and the method of emergency retrieval.

1. Single Line – Winch Only – Entry/Egress Using Ladder

When a single mechanical device is used for non-entry rescue into a confined space it serves only as backup to the worker's primary entry/egress method. In most cases the primary means of entry/egress into a vertical confined space is a ladder.

When using only a winch as the backup to the entrant's primary means of entry and egress, the attendant should take care to keep the winch line taut to avoid any potential overload due to a fall event on the winch line. The winch is not a fall arrest device and must not be subjected to fall forces. The winch is for emergency retrieval only. See Figure 1.

2. Single Line – SRL-R Only – Entry/Egress using ladder

When a single mechanical device is used for non-entry rescue into a confined space it serves only as backup to the worker's primary entry/egress method. In most cases the primary means of entry/egress into a vertical confined space is a ladder.

When using an SRL-R only as a back up to the worker's primary means of entry and egress the device cable will pay freely in and out of the housing as the entrant moves into the vertical confined space. In the event the entrant falls the SRL-R will arrest the fall and reduce fall forces applied to the body. The attendant may then engage the backup emergency retrieval winch to raise the entrant out of the confined space. The emergency retrieval winch is not to be used for ordinary entry/egress in and out of the confined space. See Figure 2.

3. Dual Line – Winch and SRL/Alternate PFAS - Entry/Egress Using Ladder

When a confined space has an existing ladder but the attendant is unable to maintain a taut winch line as the entrant descends and ascends from the confined space, it is possible to use a regular SRD or Fall Arrestor Connector Subsystem (FACSS) to provide protection from impacting and overloading the winch during a fall event.

In this case the PFAS provides fall protection as the worker freely moves vertically, and the winch provides backup as the emergency retrieval device from the confined space. See Figure 3.

4. Dual Line – Winch and SRL-R – Entry/Egress Using a Winch

When no alternate method of entry/egress (such as a ladder) exists the confined space entrant will be suspended, raised and lowered with the winch line attached to a shoulder yoke or sternal D-Ring of a Full Body Harness. An SRL-R is then attached to the dorsal D-ring of the Full Body Harness to provide fall arrest and emergency retrieval. Suspended workers are required to have a backup system to their primary means of entry/egress that will limit fall forces to the body and provide emergency retrieval in the event of a winch malfunction. See Figure 4.

APPENDIX C

