

SPEC SHEET

Commando Tank Non-Penetrating Fall Protection Cart



CMT04-SLR



WEATHER PROTECTIVE COVER

TOTAL NUMBER OF USERS:
 FALL ARREST: 2
 FALL RESTRAINT: 2

PATENT PENDING

Features	Design Specifications	
Most innovative non-penetrating fall protection cart with 2 fall arrest and 2 fall restraint points.	Color	■ Electrostatic Safety Green
4 picking points for easy lifting and placement.	Material	High Strength ASTM Rated Steel
Activates a 110 dB alarm if a fall occurs with a force exceeding 300 lbs, ensuring immediate alertness.	Application	Concrete, TPO, EPDM, Asphalt
Includes 8 slim designed solar panels powering the batteries for all electrical functions.	Lights	4,000 Lumens Each
		Lasts up to 5 hours
	Weight	± 1,500 lbs
	OSHA	1926 & 1910

COLOR CODE

Indicates the different tie-off and lifting points.

- FALL ARREST
- FALL RESTRAINT
- LIFTING POINTS

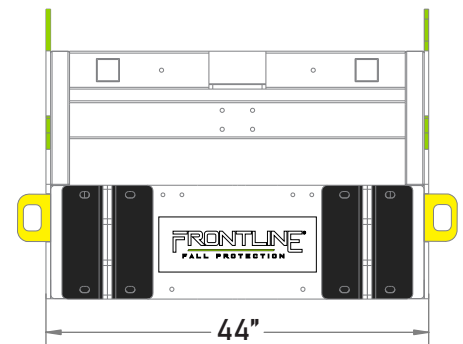
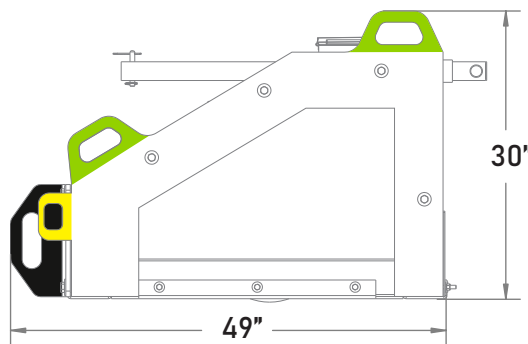

www.frontlinefall.com info@frontlinefall.com
 6 Lee Blvd, Malvern, PA 19355