

SPEC SHEET

Confined Space Davit Arm System with Floor Mount

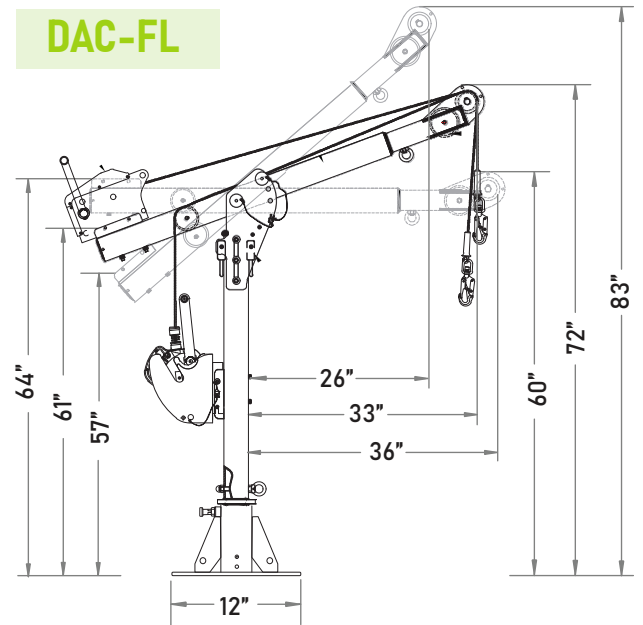

DAC-FL

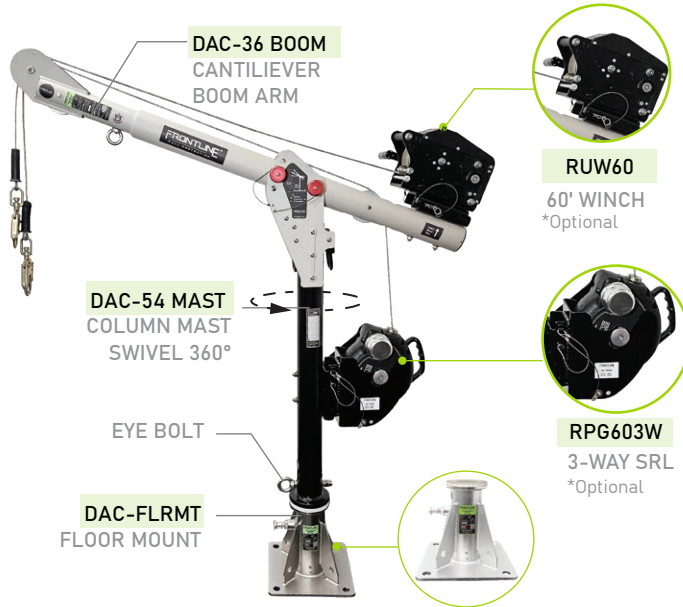

Features

Assembles into 3 main components tool-free depending on the configuration	Multiple anchorage points for rescue operations.
Compatible with various fixed and portable bases.	360-degree swiveling capability with a removable locking pin.
Adjustable cantilever arm with 3 height positions.	Pre-installed mounting brackets for winch and retrieval systems.

Design Specifications

Mounting Option	Floor Mount for Concrete or Steel Substrates	Dimensions	64" L x 12" W x 60" H
Material	High Strength Aluminum Alloy	User Capacity	310 lbs
Finish	Powder Coated	Breaking Strength	15 kN

*Optional components for the Davit System are not included and depend on the specific system, determined by the user's requirements at the time of purchase.



www.frontlinefall.com info@frontlinefall.com
6 Lee Blvd, Malvern, PA 19355

SPEC SHEET

Confined Space Davit Arm System with Floor Mount



DAC-FL

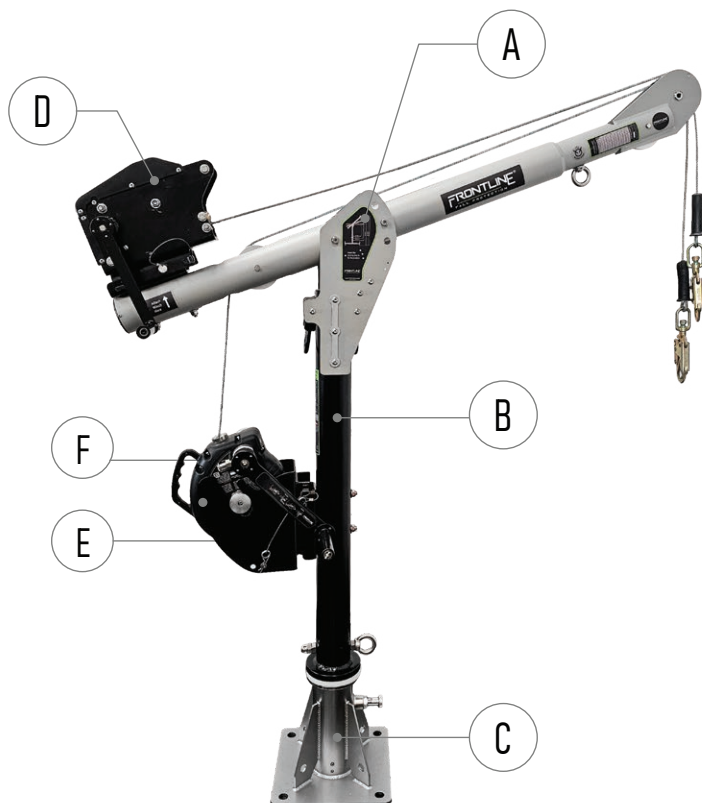

Relevant Standards

OSHA	1926
	1910
ANSI	Z359.18

Cantilever Arm Positions

Position	Height	Reach
Upper	26"	83"
Middle	33"	72"
Lower	36"	60"

KIT COMPONENTS

SKU	Weight	DAC-36BOOM	DAC-54MAST	DAC-FLRMT	WINCH	3-WAY	3-WAY BRACKET
DAC-FL	88 lbs	✓	✓	✓	●	●	●
DAC-FL-WINCH	114 lbs	✓	✓	✓	✓	●	●
DAC-FL-WINCH-3 WAY	146 lbs	✓	✓	✓	✓	✓	✓

