

SPEC SHEET

Confined Space Davit Arm System with Wall Mount

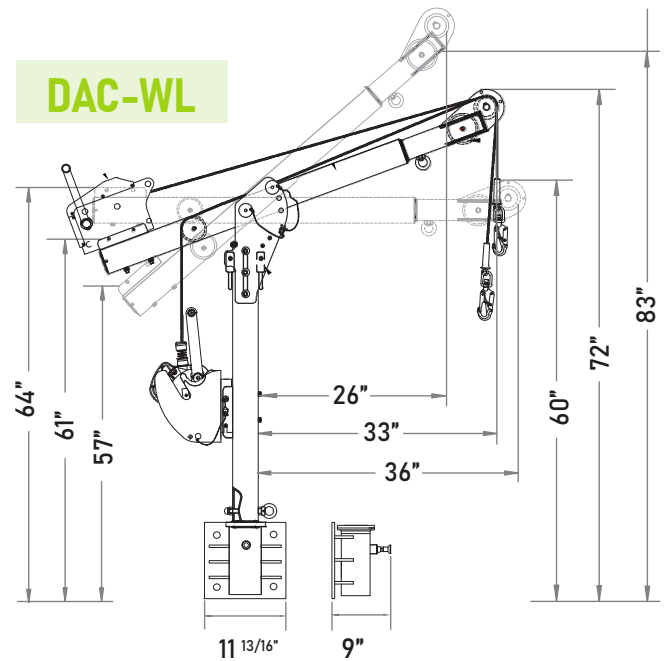

DAC-WL

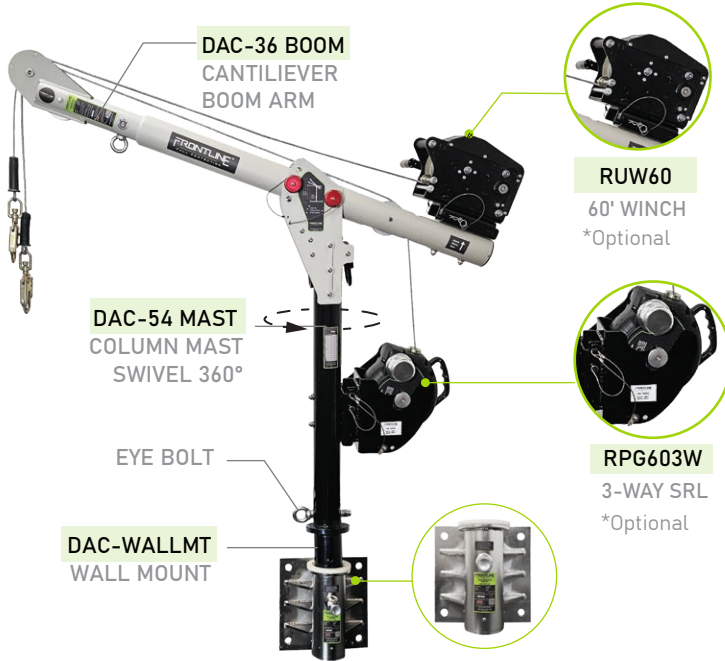

Features

| | |
|---|--|
| Assembles into 3 main components tool-free depending on the configuration | Multiple anchorage points for rescue operations. |
| Compatible with various fixed and portable bases. | 360-degree swiveling capability with a removable locking pin. |
| Adjustable cantilever arm with 3 height positions. | Pre-installed mounting brackets for winch and retrieval systems. |

Design Specifications

| | | | |
|------------------------|---|--------------------------|----------------------|
| Mounting Option | Wall Mount for Concrete or Steel Substrates | Dimensions | 64" L x 9" W x 60" H |
| Material | High Strength Aluminum Alloy | User Capacity | 310 lbs |
| Finish | Powder Coated | Breaking Strength | 15 kN |

*Optional components for the Davit System are not included and depend on the specific system, determined by the user's requirements at the time of purchase.



www.frontlinefall.com info@frontlinefall.com
6 Lee Blvd, Malvern, PA 19355

SPEC SHEET

Confined Space Davit Arm System with Wall Mount



DAC-WL

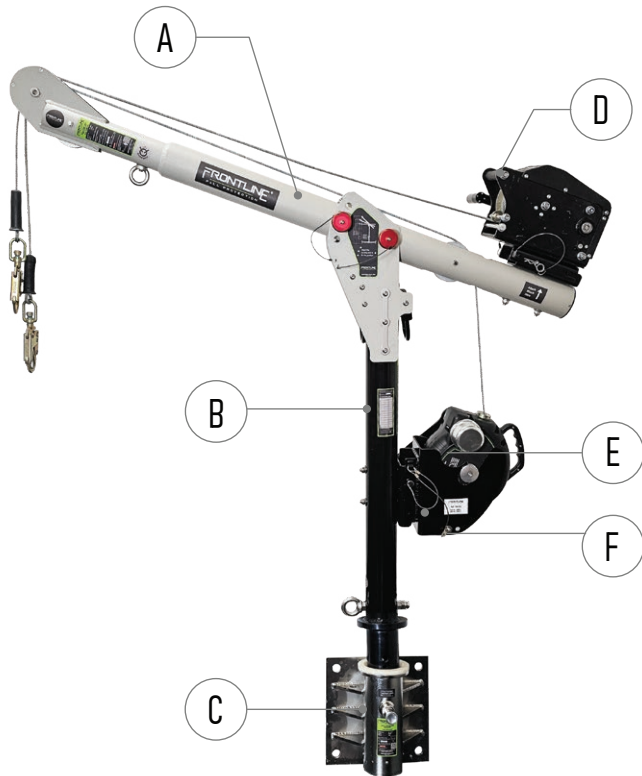

Relevant Standards

| | |
|------|---------|
| OSHA | 1926 |
| | 1910 |
| ANSI | Z359.18 |

Cantilever Arm Positions

| Position | Height | Reach |
|----------|--------|-------|
| Upper | 26" | 83" |
| Middle | 33" | 72" |
| Lower | 36" | 60" |

KIT COMPONENTS

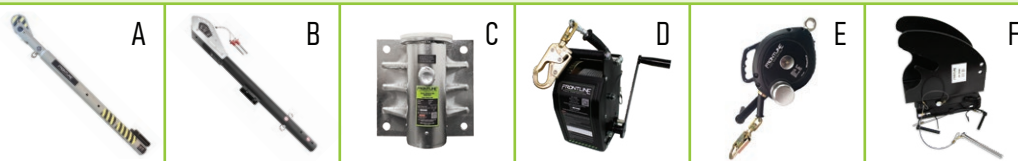

| SKU | Weight | DAC-36BOOM | DAC-54MAST | DAC-WALLMT | WINCH | 3-WAY | 3-WAY BRACKET |
|--------------------|-----------|------------|------------|------------|-------|-------|---------------|
| DAC-WL | 92.5 lbs | ✓ | ✓ | ✓ | ● | ● | ● |
| DAC-WL-WINCH | 118.5 lbs | ✓ | ✓ | ✓ | ✓ | ● | ● |
| DAC-WL-WINCH-3 WAY | 150.5 lbs | ✓ | ✓ | ✓ | ✓ | ✓ | ✓ |

