

INSTRUCTION **MANUAL**

# **FRONTLINE**<sup>®</sup>

---

F A L L P R O T E C T I O N



USER MANUAL

**PARAPET GRABBING SYSTEM**

GUP2X4

Rev. Mar. 2026



Frontline Fall Protection Inc.  
INSTRUCTION MANUAL

Applicable standards, compliance and/or regulations conformance may depend on various factors included but not limited to Federal/State/Local requirements, the type of work being done, application, substrate installation, particular anchor being used and/or potentially other factors. Check user manual for full details and with a qualified person before install. Refer to local, state, and federal (OSHA) requirements for additional information concerning the governing body of occupational safety regarding Personal Fall Arrest Systems (PFAS).

All users must refer to local, state or federal safety and health regulations before using this equipment. If there's a contradiction between any local, state, federal requirement and/or standard with this manual or within this manual, whichever is the most stringent will apply.

You are required to read and fully understand the user instruction manual BEFORE using this product. Improper use and installation can result in serious injury or death. User manuals occasionally may be updated so for the latest user manual please visit

**[www.frontlinefall.com/uim](http://www.frontlinefall.com/uim)**.

**TABLE OF CONTENTS**

Definitions _____	4
General Statement and Warnings _____	6
Training Requirements _____	7
Application _____	8
Installation _____	9
Maintenance, Storage and Transportation _____	11
Inspection checklist and Log _____	12
Labels _____	14

**DEFINITIONS:** For better use and understanding, the following is some terminology and definitions as referenced by OSHA that may help better understand this user manual. Please refer to OSHA 1910 or 1926 for full details.

**Anchorage**

A secure point of attachment for lifelines, lanyards, or deceleration devices.

**Attachment Point**

A loop or "D" ring connected (integrally) to the body support that provides a means for attachment of other components of the fall protection system.

**Body Harness**

Means straps, which may be secured about the worker in a manner that will distribute the fall arrest forces over at least the thighs, pelvis, waist, chest and shoulders with means for attaching it to other components of a personal fall arrest system.

**Carabiner**

A link with a gate that is normally closed or that automatically closes, and is used to connect components of a personal fall protection system.

**Competent Person**

Is defined as "one who is capable of identifying existing and predictable hazards in the surroundings or working conditions which are unsanitary, hazardous, or dangerous to employees, and who has authorization to take prompt corrective measures to eliminate them" [29 CFR 1926.32(f)]. By way of training and/or experience, a competent person is knowledgeable of applicable standards, is capable of identifying workplace hazards relating to the specific operation and has the authority to correct them.

**Connector**

A device which is used to couple (connect) parts of the personal fall arrest system and positioning device systems. It may be an independent component of the system, such as a carabiner, or it may be an integral component of part of the system (such as a buckle or D-ring sewn into a body belt or body harness, or a snap-hook spliced or sewn to a lanyard or self-retracting lanyard).

**D Ring**

A form of attachment point on body belts and fully body harnesses meant for attachment of other components of a fall protection and positioning system.

**Deceleration Device**

Means any mechanism that serves to dissipate energy during a fall.

**Deceleration Distance**

The vertical distance a falling employee travels from the point at which the deceleration device begins to operate, excluding lifeline elongation and free fall distance, until stopping. It is measured as the distance between the location of an employee's body harness attachment point at the moment of activation (at the onset of fall arrest forces) of the deceleration device during a fall, and the location of that attachment point after the employee comes to a full stop.

**Fall Arrest System**

A fall arrest system means a system used to arrest an employee in a fall from a working level. It consists of an anchor point, connectors, a body belt or body harness and may include a lanyard, deceleration device, lifeline, or suitable combinations of these.

**Fall Prevention System**

Those systems and techniques that eliminate the possibility of a fall.

**Fall Protection System**

Any of the following when used to protect a worker from a fall or minimize the risk from falling: Guardrails, Safety belt or a full body harness with a lanyard and/or lifeline and an anchor, and their related equipment, Safety net, Control zone, Safety monitor with a control zone, and other acceptable procedures.

**Fall Restraint System**

A work positioning system to prevent a worker from falling from a work position, or a travel restriction system such as guardrails or a personal fall protection system to prevent a worker from traveling to an edge from which the worker could fall.

**Free Fall**

The act of falling before the personal fall arrest system begins to apply force to arrest the fall.

**Free Fall Distance**

Vertical displacement of the fall arrest attachment point on the employee's body belt or body harness between onset of the fall and just before the system begins to apply force to arrest the fall. This distance excludes deceleration distance, lifeline and lanyard elongation, but includes any

deceleration device slide distance or self-retracting lifeline/lanyard extension before the devices operate and fall arrest forces occur.

### **Full Body Harness**

A body support device consisting of connected straps designed to distribute a fall arresting force over at least the thigh, shoulders and pelvis, with provision for attaching a lanyard, lifeline or other components.

### **Lanyard**

A flexible line of webbing, synthetic rope or wire rope that is used to secure a safety belt or full body harness to a lifeline or anchor.

### **Horizontal Lifeline System**

A system composed of a synthetic or wire rope installed horizontally between two anchors, to which a worker attaches a personal fall protection system.

### **Leading Edge**

The edge of a floor, roof, or formwork for a floor or other walking or working surface (such as the deck) which changes location as additional floor, roof, decking, or formwork sections are placed, formed, or constructed. A leading edge is considered to be an "unprotected side and edge" during periods when it is not actively and continuously under construction.

### **Lifeline**

A synthetic or wire rope, rigged from one or more anchors, to which a worker's lanyard or other part of a personal fall protection system is attached.

### **Low-Slope Roof**

A roof having a slope less than or equal to 4 in 12 (vertical to horizontal).

### **Lower Levels**

Those areas or surfaces to which a worker can fall. Such areas or surfaces include, but are not limited to, ground levels, floors, platforms, ramps, runways, excavations, pits, tanks, material, water, equipment, structures, or portions thereof.

### **Passive Fall Prevention**

Refers to a system that is non-dynamic, stationary, and does not move, adapt, or change when in or out of use. Passive systems don't require the use of personal protective equipment or active participation from the worker. Typically, passive systems include netting, handrails, and guardrails.

### **Personal Fall Arrest System (PFAS)**

A system used to arrest an employee in a fall from a working level. It consists of an anchorage, connectors, a body belt or body harness and may include a lanyard, deceleration device, lifeline or suitable combinations of these. As of January 1, 1998, the use of a body belt for fall arrest is prohibited.

### **Positioning System (work-positioning system)**

A system of equipment and connectors that, when used with a body harness or body belt, allows an employee to be supported on an elevated vertical surface, such as a wall or window sill, and work with both hands free. Positioning systems also are called "positioning system devices" and "work-positioning equipment".

### **Qualified**

A person who, by possession of a recognized degree, certificate, or professional standing, or who by extensive knowledge, training, and experience has successfully demonstrated the ability to solve or resolve problems relating to the subject matter, the work, or the project.

### **Rope Grab**

A deceleration device which travels on a lifeline and automatically, by friction, engages the lifeline and locks so as to arrest the fall of an employee. A rope grab usually employs the principle of inertial locking, cam/level locking or both (also referred to as a fall arrester).

### **Self-Retracting Lifeline/Lanyard**

A deceleration device containing a drum-wound line, which can be slowly extracted from, or retracted onto, the drum under slight tension during normal worker movement, and which, after onset of a fall, automatically locks the drum and arrests the fall.

### **Shock Absorber**

A device intended to limit the deceleration forces exerted on a worker during fall arrest.

### **Snap Hooks**

A connector consists of a hook-shaped member with a normally closed keeper, or similar arrangement, which may be opened to permit the hook to receive an object and, when released, automatically closes to retain the object.

### **Unprotected Sides and Edges**

Any side or edge (except at entrances to points of access) of a walking or working surface (for

example, floor, roof, ramp, or runway) where there is no wall or guardrail system at least 39 inches high.

### **Walking/Working Surface**

Any surface (whether horizontal or vertical) on which a worker walks or works, including but not limited to floors, roofs, ramps, bridges, runways, formwork and concrete reinforcing steel; but not including ladders, vehicles, or trailers, on which workers must be located in order to perform their job duties.

### **Warning Line System**

A barrier erected on a roof to warn workers that they are approaching an unprotected roof side or edge, and which designates an area in which roofing work may take place without the use of guardrail, body harness, or safety net systems to protect workers in the area.

### **Working load**

Refers to aggregate simultaneous load of personnel, equipment, and/or material to be supported by the equipment or system.

## **GENERAL STATEMENT AND WARNINGS**

This parapet grabbing system is meant to be used ONLY by trained personnel in fall protection. This parapet grabbing system is ONLY intended for use as part of a complete personal fall protection system. This parapet grabbing system has been designed to meet or exceed OSHA 1926 and/or OSHA 1910.

User MUST read, understand, and follow all safety information contained in these instructions prior to the use of this parapet grabbing system. Use in any other applications including, but not limited to, material handling, recreational or sports related activities, or other activities not described in the User Instructions is not approved by Frontline Fall Protection and could result in serious injury or death. This device is only to be used by trained users in workplace applications.

These instructions must be provided to the user of this equipment. Retain these instructions for future reference or you can find a copy of them at [www.frontlinefall.com](http://www.frontlinefall.com) for more information regarding any portion of this user instructions manual please contact us at [info@frontlinefall.com](mailto:info@frontlinefall.com).

- Do not use this equipment until proper training, fall protection and rescue programs are in place.
- Do not use this equipment in combination with other components or subsystems other than those described in this manual.
- Do not use this equipment for other uses other than its original and designed intended use.
- Do not use product that has been impacted to a fall, that does not pass inspection or that the safety and integrity of it is questionable.
- Consult a doctor prior using this equipment to ensure user is in physical conditions to use this equipment and if physical fit in the event there's a fall.
- Pregnant women or minors must not be exposed to a workplace hazard and must not use this equipment.
- Avoid sharp and/or abrasive surfaces and edges as this will compromise the safety of the Personal Fall Arrest System.
- All user must refer to local, state or federal safety and health regulations before using this equipment. Whichever is most stringent shall supersede and apply.
- Avoid moving machinery, thermal, electrical, and/or chemical hazards as contact may cause serious injury or death.
- Avoid swing falls at all times when using Personal Fall Arrest Systems.
- Follow the weight restrictions/limitations in this manual.
- Never alter or intentionally misuse this equipment, always inspect before each use to ensure its compliance and safe use.
- Never connect rebar hooks, large carabiners, large snaphooks or non- approved hooks/connectors to the full body harnesses dorsal D-rings as this may cause a roll-out and/or unintentional disengagement.
- Avoid contact with arc flash welding at all times. Arc flash from arc welding operations, including accidental arcs from electrical equipment, can damage the PFAS equipment resulting in injury or death.
- Always examine the work area and the surroundings to identify hazards that may impact safety and proper functioning of the Personal Fall Arrest System before commencing work.

- Only one fall protection system or positioning system may be attached to an individual connection point.

## **INSPECTION REQUIREMENTS**

This parapet grabbing system and any other PFAS shall be inspected BEFORE each use. The program administrator, authorized user and/or rescuer inspecting the product shall have the proper training on the use, maintenance, care and inspection of this product. Additionally, a competent or qualified person other than the user shall conduct thorough safety inspections every 6 months or sooner, when necessary or required by the authorized user or employer. Some of the items that shall be inspected, but not all inclusive, are the following:

- Safety labels/markings/tags that are legible with appropriate OSHA/ANSI markings, product limitations, user capacity and other markings as required by OSHA/ANSI.
- Defects or any imperfections on the products such as; Corrosion, broken, bent, deformed, excessive wear, defects in welded areas or any other evidence of damage or alterations affecting the safety functionality of the parapet grabbing system.
- Any other conditions that may question the integrity of the parapet grabbing system, shall be put out of service.
- Any product that has been subject to a fall or an impact, shall be put out of service.
- Clean/clear product of any surface contamination such as concrete, stucco, roofing material or other material that may impact the safe use of the product.
- Any damage to the equipment or inadequate maintenance.
- The details of the "Inspection Checklist and Log" at the end of this manual.

Permanently remove equipment from service that does not pass any of these inspection criteria, hasn't undergone preventative service or maintenance requirements or if the equipment is questionable.

As required by ANSI Z359.18 6.1.2/6.1.3, the "The program administrator shall set inspection criteria for the equipment. Such criteria shall equal or exceed the most restrictive of the criteria established by this standard or the manufacturer's user instructions. Keep inspection criteria current in relationship to changing patterns or conditions of use. The program administrator shall maintain documentation of equipment inspections. This documentation shall include, at a minimum, the identity of the equipment, inspection date, name of the competent or qualified person conducting the inspection and the results of that inspection."

These are minimum requirements, and all inspections should be documented for recordkeeping. Any questions regarding the safety inspection of Frontline Fall Protection products please contact us at [info@frontlinefall.com](mailto:info@frontlinefall.com).

## **TRAINING REQUIREMENTS**

Before using Frontline Fall Protection product, user and employers must ensure that the person using this equipment has been trained on the proper use, care and maintenance of this product by a competent person qualified in Fall Protection. It is the responsibility of the user of this product to ensure that proper training has been done in addition to reading and fully understanding these user instructions manual.

Additionally, the employer must establish a training program to employees that are exposed to a fall hazard and trained by a competent person qualified in those areas. The program shall enable each employee to recognize the hazards of falling and shall train each employee in the procedures to be followed in order to minimize these hazards.

Retraining is necessary when the employer has reason to believe that any affected employee who has already been trained does not have the understanding and skill to carry out those duties. Circumstances where retraining is required include, but are not limited to, situations where:

- Changes in the workplace render previous training obsolete.
- Changes in the types of fall protection systems or equipment to be used render previous training obsolete.

- Inadequacies in an affected employee's knowledge or use of fall protection systems or equipment indicate that the employee has not retained the requisite understanding or skill.
- Changes in the OSHA regulations or ANSI Standards.

Training must be done in the language that the employee understands and shall, be documented and kept as outlined under OSHA recordkeeping regulations. No user or employee shall perform work without the proper training and understanding on how to properly and safely use this product.

## GENERAL DISCLAIMER

Frontline has tested their product to comply with OSHA and/or ANSI under a controlled environment and with certain substrates. Frontline cannot and does not guarantee the same performance for different substrates other than the ones mentioned in these user manuals. Frontline parapet grabbing system will meet or exceed OSHA and/or ANSI requirements, but it's ultimately up to the end user/installer/owner of the product to ensure that their specific substrate will resist and withstand the required loads as stated by OSHA and/or ANSI or other governing safety entities. Please contact [info@frontlinefall.com](mailto:info@frontlinefall.com) if you have any questions regarding this subject matter.

**WARNING** – When installing the parapet grabbers onto the structure please keep in mind the workers beneath your work area so there's no potential of falling tools, objects or the different equipment. Tether and use other means of protection to protect people/workers from lower levels from overhead hazards.

## APPLICATION

This system has been designed to serve as a passive fall prevention system. This system should be set-up anywhere where there is a fall hazard over a building's parapet wall that is over 4' for general industries and 6' for the construction industry. Refer to state and local safety regulations in case there's a more stringent requirement, as the most stringent will apply. Once the system has effectively been installed, set in place and fall hazard eliminated, the use of active fall arrest systems may not be required. Check with your employer for more details on fall protection compliance if the area is questionable.

### Component Names:

In order to help installation guidance, the following are the component names:

FIGURE 1

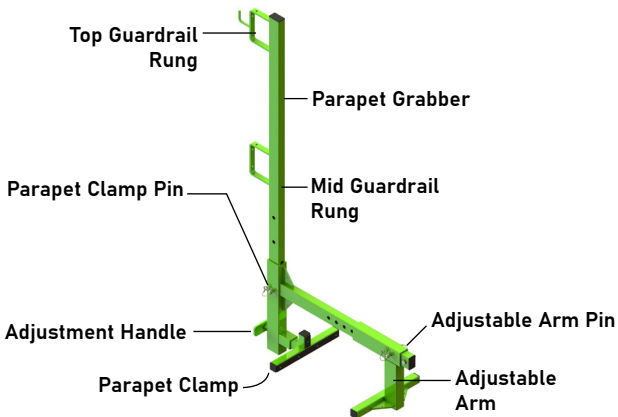

## INSTALLATION

Before installing the parapet system Frontline requires that the substrate withstand the minimum required loads as mentioned by OSHA 1926/1910 of 200 lbs of force without failure in order to support the system and be approved before use by a qualified person. The parapet wall must be a minimum of 10" high so that the adjustable arm and parapet system lie flat and unobstructed on the parapet. The parapet wall must also have a maximum width of no greater than 13". Do not install on an incline, on slippery surfaces or other surfaces/finishes that is not completely flat. If the parapet wall meets these criteria, then follow the instructions below in order to proceed to installation:

A layout plan should be done of the fall hazard exposed area which is being covered prior to installation so that the proper lineal foot amount of parapet grabbing system is accounted for. Once the parapet grabbing system is onsite and ready to be installed, the following steps must be followed:

1. Parapet must be FULLY cured/secured to the building structure in order to install the parapet grabbers.
2. The perimeter of the work area must be fully installed and completely covered with the parapet grabbing system in order to eliminate fall hazard exposure.
3. Before installing, ensure that employees/users doing the installation have fall protection if exposed to a fall hazard
4. Measure the parapet wall thickness. Thereafter, remove the pin from the Adjustable Arm and close the system to the nearest hole position based on thickness of the parapet wall so it can slide into the parapet wall.
  - a. Ensure there's enough clearance so that the system can be inserted into the parapet wall (Figure 2).
5. Now, position the parapet grabbing clamp between the parapet. The parapet grabber must be in an upright position with the guardrail rungs and parapet clamp on the walking/working side of parapet as shown on Figure 3.

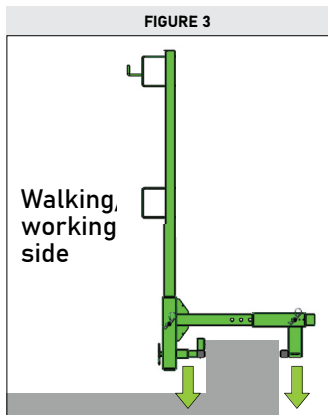
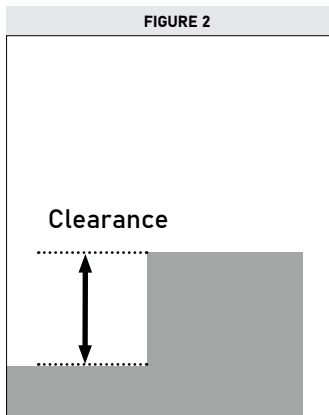

6. Now, turn the Adjustment Handle clockwise in order to tighten onto the inner parapet wall as tight and with as much as pressure possible to fully secure the parapet anchor to the wall as shown on figure 4.

a. Parapet system cannot be loose or unstable, anchor MUST be of tight and secure fit on parapet wall.

FIGURE 4

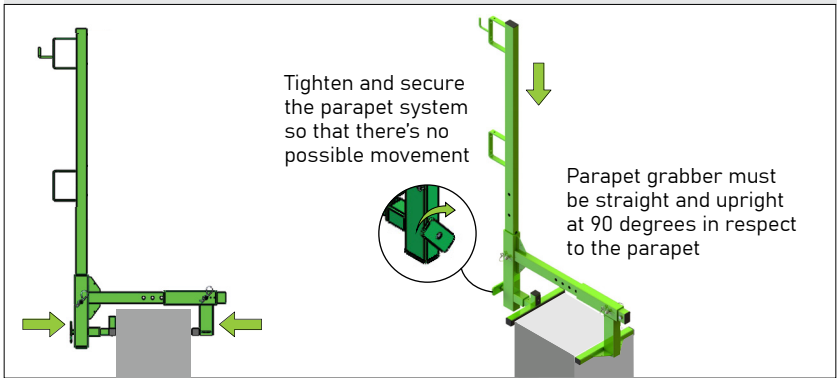

**Note:** Turn clockwise to close parapet grabber and to tighten, turn counter clockwise to loosen and open parapet grabber.

7. Do a slight pull/push test to ensure that the parapet grabber is secured. Loose parapet grabbers are a sign of improper installation.

8. The post height is adjustable by unlocking the pin from the parapet clamp. Set to a minimum of 42" ± 3" from the walking/working surface then reinsert and secure the pin as shown in Figure 5:

FIGURE 5

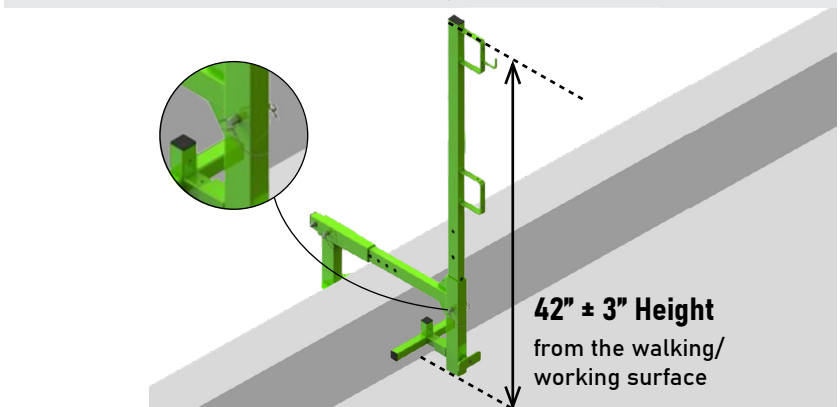

9. Install another parapet grabber no more than 8' apart by repeating the same steps listed above.
10. Thereafter, start feeding top and mid guardrail rungs with 2" x 4" wooden supports with a minimum of 12" overlap as shown on Figure 6:
- a. Nail or screw and secure 2" x 4" guardrails through Parapet Guardrail Rungs as shown on Figure 6.

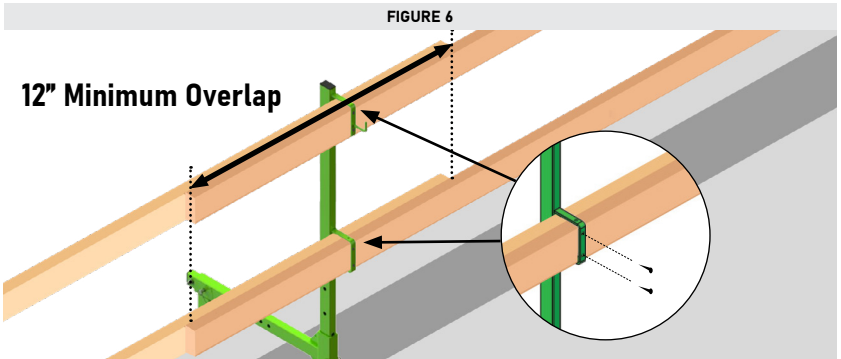

11. Repeat all these steps and process along the perimeter of the desired area with parapet grabbers no more than 8' apart as shown on Figure 7:

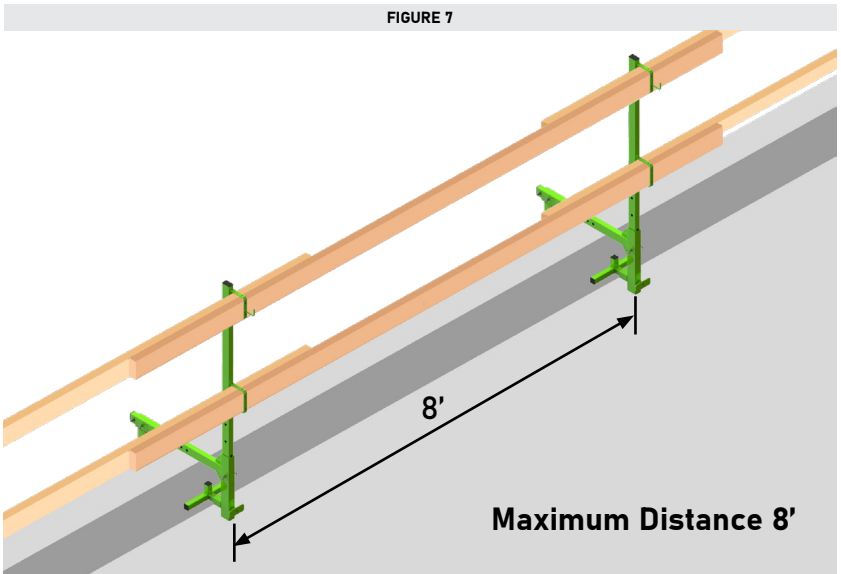

12. Visually and physically inspect that the parapet grabbing systems are fully and properly installed.

13. Once correctly installed and inspected, system is ready to be used.

**WARNING:** Parapet wall must be fully cured if it's concrete/masonry or be of part of the building structure and be able to withstand the required load as mentioned by OSHA 1926/1910 of 200 lbs of force without failure to safely secure the system and without deflection.

### **MAINTENANCE, STORAGE & TRANSPORTATION**

**MAINTENANCE:** Maintenance can be done on site competent person to ensure slab grabbers and well positioned and not lose. Competent person also should inspect the wooden 2"x4" guardrails to ensure that they are well maintained and that their integrity is not compromised. If there's a product that does not pass inspection or is questionable it needs to be taken out of service immediately.

In order to maintain product in good standing, it is necessary to keep them cleaned and in good condition. Avoid surface contamination such as concrete, stucco, roofing material, chemicals or other harmful substances that could accelerate cutting, abrading, damaging and/or rusting/corroding of products. Use warm water and soap to wash any containments and then dry off to help extend the life of the product.

Product that needs to undergo deeper maintenance and repairs outside of cleaning with warm water and soap is not recommended. Any rust preventative measures, chemical exposures repairs/maintenance and/or other deeper maintenance are in the sole responsibility of the user and must be approved by a qualified person. Frontline assumes and takes no responsibility for maintenance measures outside of light maintenance as described above. Product that does not pass inspection or is questionable needs to be taken out of service immediately.

**STORAGE:** If products are not temporarily or permanently installed, when possible, all products shall be stored at room temperature in indoor space, lockers or in a clean area away from sunlight, rain and other environmental conditions. Products should be also stored where they are not exposed to chemical, oils, paint, concrete, or other contaminants that might compromise the integrity of the product. Equipment that has been physically exposed such as rain/dirty water, concrete, paint, buildup of other construction material or other surface contamination shall be cleaned and dried before storage.

**TRANSPORTATION:** Ensure to transport product where it doesn't beat up against other products as this might cause damage to products and terminate the use of them. Product also should not be transported with harmful substances or chemicals as this might also compromised the integrity of the product.





**WARNING TO USER:**  
 We are required to test and fully understand the user instruction manual (UIM) every two product improvement and installation can result in serious injury or death. Your manuals occasionally may be updated so for the latest user manual please visit [www.frontlinefall.com](http://www.frontlinefall.com).



6 07478 244250 2

**PARAPET GRABBER**  
 Compliance: OSHA 1926.502(a) 1926

**PART N°** GUP2X4GRN

**BATCH N°** 101

**DOM** 18-109 01-2026

1. Insert the Parapet Grabber upright with parallel rungs facing the working side.
 

2. Turn the adjustment handle clockwise and tighten fully until the unit is firmly secured.
 



3. Set to a height of 42" x 3" from the walking/working surface, then reinsert and secure pin.
 



**42" x 3"**  
Height
4. Perform a push/pull test. If loose, reinstall. Install additional units no more than 8 ft apart.
 



**8'**
5. Insert and secure 2" x 4" top and mid rails with minimum 12" overlap.
 

4. Repeat around the entire perimeter.
 

CONSULT INSTALLATION MANUAL



**FRONTLINE FALL PROTECTION INC.**  
[www.frontlinefall.com](http://www.frontlinefall.com) Made in Columbia  
 800-955-6666

**WARNING:** The labels are of reference and must be reviewed for local code and regulations. Not all are applicable. Fully read user instruction manual to ensure fully understood how to properly install parapet grabbers.





**Frontline Fall Protection Inc.**

[www.frontlinefall.com](http://www.frontlinefall.com)

[info@frontlinefall.com](mailto:info@frontlinefall.com)

©2026 Frontline