

# SPEC SHEET

## Ladder Safety Dock



LAC12

### Features

Provides a non-penetrating and fixed secure points of attachment to roof parapet walls\*

Can also be installed on flat roof surfaces by fixing it

Rubber pads protect walls with adjustable widths

Retro-reflective tape for enhanced visibility and trip prevention.

Quick and easy to install, no tools needed for non-penetrating install

### Features and Specs

Material ASTM rated steel

Finish Electrostatic paint

Weight 25 lbs

Max Ladder Width 17"

Load Capacity Type 1A - 300 lbs

Ladder Type Extension Ladder  
Up to Special Duty - Type IA

### Relevant Standards

OSHA 1926.1053(b)(1)

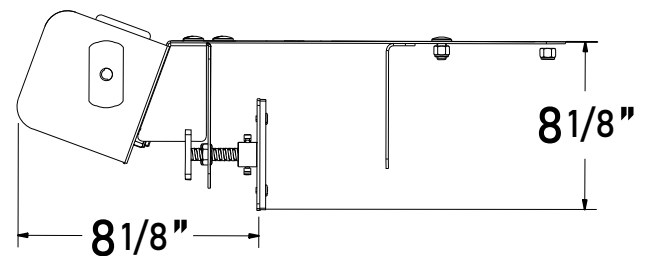
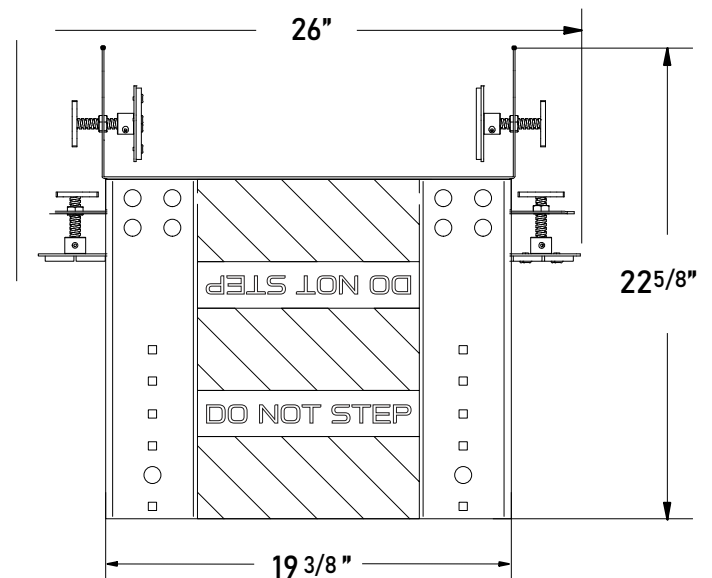

\*See user manual for more details

**FRONTLINE**  
FALL PROTECTION

www.frontlinefall.com info@frontlinefall.com

6 Lee Blvd, Malvern, PA 19355