

# SPEC SHEET

## Universal Ladder Stabilizer



LAS48

### Features

Enhances ladder stability against walls

Protects building facade with rubber ladder stabilizer ends

Reflective tape for enhanced night visibility

Universal fit, adjusting to most ladders

### Features and Specs

Material                      ASTM rated steel

Weight                              6 lbs

Adjustable Width                40" - 46"

Length to the wall                12"

Load Capacity                    Type 1A - 300 lbs

Ladder Type                      Straight or Extension  
Ladder / Extra Heavy  
Duty - Type IA

### Relevant Standards

ANSI                                  A14.8-2020

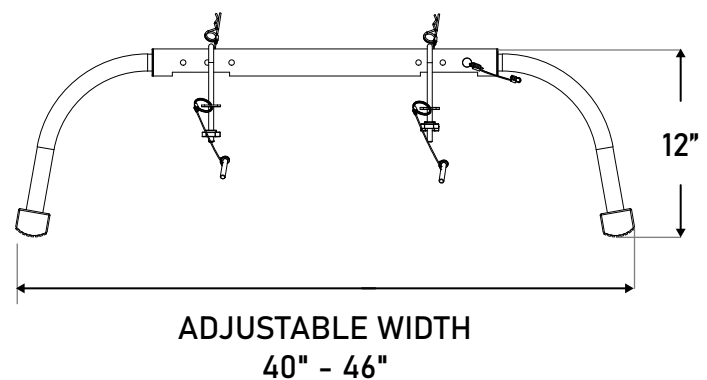
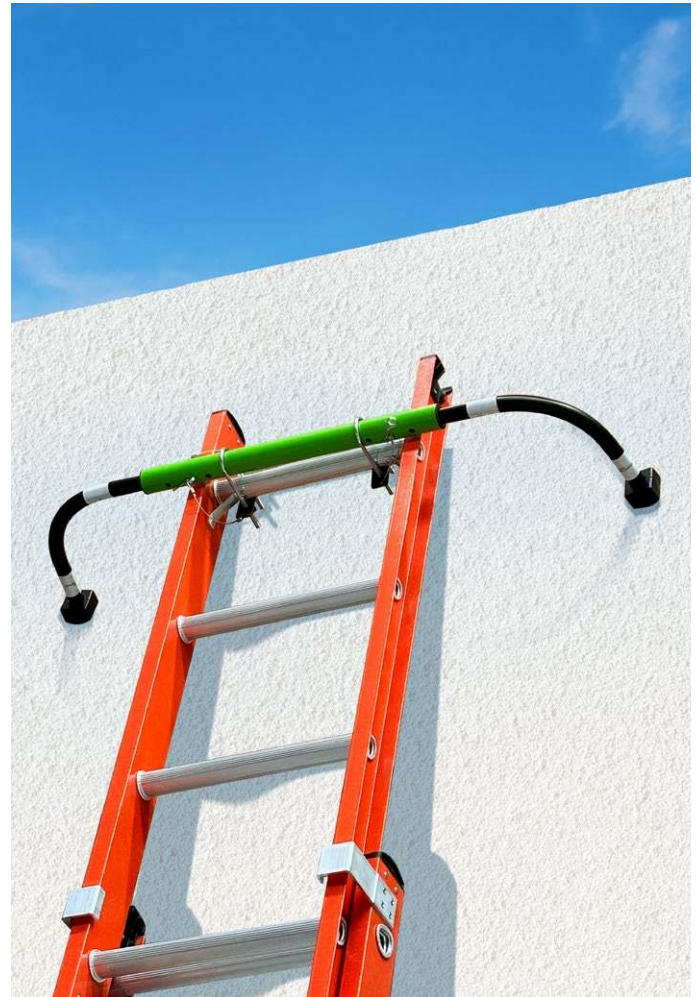

www.frontlinefall.com    info@frontlinefall.com

6 Lee Blvd, Malvern, PA 19355