

INSTRUCTION **MANUAL**

FRONTLINE[®]

FALL PROTECTION

USER MANUAL

ROOFER KITS

RK5PTB50, RK050V50, RK110V50 and RK5PTB25

Meets or exceeds
applicable standards

Rev. Oct . 2024



Warning	Page 3
1. Limitations for Use	Page 4
2. Anchorage Requirements	Page 4
3. Connection Compatibility Limitations	Page 5
4. Fall Clearance/Clear Fall Charts	Page 5-6
5. Donning	Page 7
6. Training	Page 7
7. Inspection	Page 8
8. Cleaning, Maintenance and Storage	Page 8
9. Labeling	Page 9
10. Annex A	Page 10-12
11. Checking Card	Page 12

Warning

- This User Instruction Manual is not to be removed except by the user of this equipment.
- Current User Instruction Manuals must always be available to the user.
- Read and understand these instructions before using equipment.
- Do not throw away these instructions.
- Do not alter the equipment.
- Do not misuse the equipment.
- Failure to follow all instructions and limitations on the use of this equipment may result in serious personal injury or death.
- Prior to each use, inspect all personal fall arrest system equipment for wear, damage, and other deterioration. Defective components must be removed from service immediately.
- After a fall, the Full Body Harness must be removed from service and destroyed immediately.
- Thoroughly evaluate and plan all elements of your fall protection system(s) before using your equipment. Make sure that your system is appropriate for your needs and facility. Also be sure to calculate fall clearance and swing fall clearance.
- Users must have a rescue plan and the means to implement it. This plan must provide prompt employee rescue or assure that employees have the ability to rescue themselves in the event of a fall.
- Store this equipment in a cool, dry, and clean environment that is out of direct sunlight when not in use.
- After a fall occurs, this equipment must be removed from service and destroyed immediately. Before each use, need inspection of load indicators.
- Failure to follow all instructions and limitations on the use of Personal Energy Absorbers and Energy Absorbing Lanyards may result in serious personal injury or death.
- Failure to have the leg straps of the Full Body Harness properly adjusted in the event of a fall arrest may result in serious personal injury or death.
- Never attach the unused leg of the lanyard back to the Full Body Harness anywhere other than an approved lanyard storage keeper.
- To minimize the potential for accidental disengagement, a Competent Person must ensure system compatibility.
- All equipment must be inspected before each use according to the instructions found in this User Instruction Manual. All equipment should be inspected by a qualified person on a regular basis.
- Never use fall protection equipment for purposes other than those for which it was designed.
- Environmental hazards should be considered when selecting fall protection equipment.
- Do not expose the equipment to any hazard which it is not designed to withstand. Consult FRONTLINE in cases of doubt.
- Never remove product labels because they include important information for the Authorized Person/User.
- Only FRONTLINE, or persons or entities authorized in writing by FRONTLINE, make repairs to the equipment.
- Do not expose equipment to environmental hazards and chemicals which may produce a harmful effect. Polyester should be used in certain chemical or acidic environments.
- Do not using combinations of components or sub-systems, or both, which may affect or interfere with the safe function of each other.
- when use the harness please follow the user information and take the proper method of use, and follow the limitations of the equipment.
- Do not allow equipment to come in contact with anything that will damage it including (but not limited to): sharp edges, abrasive surfaces, moving machinery, or high-temperature applications like welding, heat sources, and electrical areas.

1.Limitations for Use

- This equipment is designed to be used in temperatures ranging from -40°F to +130°F (-40°C to +54°C).
- Do not expose this equipment to chemicals or harsh solutions that may have a harmful effect. Contact **FRONTLINE** with any questions.
- Use caution when working with this product near moving machinery, electrical hazards, sharp edges, or abrasive surfaces, as contact may cause equipment failure, personal injury, or death.
- Minors, pregnant women, and anyone with a history of back and/or neck problems should not use this equipment.
- Do not use or install equipment without proper training from a “Competent Person”.
- Full Body Harnesses are designed for users with a maximum capacity up to 310 lb.* (141 kg.) Including clothing, tools, etc.

**If the system is used by an employee having a combined tool and body weight between 310 lb. (140.6 kg.) and 400 lb. (181.4 kg.), then the employer must appropriately modify the criteria and protocols to provide proper protection for such heavier weights, or the system will not be deemed to be in compliance with the requirements of OSHA 1926.502(d) (16). [ANSI capacity range is 130 lb. – 310 lb. (59 kg. – 140.6 kg.).]*

- Full Body Harnesses shall be used as part of a personal fall arrest system that limits the maximum free fall distance to 6 ft. (1.8 m). If used with appropriate connecting system, Full Body Harnesses may be used with free falls exceeding 6 ft. (1.8 m).
- Full Body Harnesses shall only be used as part of a controlled descent or rescue system that eliminates free fall unless attached to the dorsal D-ring. When attached to the dorsal D-ring, the maximum free fall distance is 6 ft. (1.8 m).
- Full Body Harnesses shall only be used as part of a work positioning system that limits the maximum free fall distance to 2 ft. (0.6 m).
- Only use components rated for the same weight capacity or Higher. Not all fall protection components are rated for the same user weight capacity.
- Proper precautions should always be taken to remove any obstructions, debris, material, or other recognized hazards from the work area that could cause injuries or interfere with the effective operation of the system.
- Do not use fall protection equipment for towing or hoisting.
- Protect all synthetic material from slag, hot sparks, open flames, or other heat sources.
- Evaluate space below work area to ensure potential fall path is clear of obstructions.
- Allow adequate fall clearance below the work surface.

2.Anchorage Requirements

All anchorages to which the Personal Energy Absorbers and Energy Absorbing Lanyards attach must meet the requirements as following:

Anchorage to which personal fall arrest equipment is attached shall be capable of supporting at least 5,000 lb. (22.2 KN) per employee attached, or shall be designed, installed, and used as part of a complete personal fall arrest system which maintains a safety factor of at least two, under the supervision of a qualified person.

The anchorages in a personal fall arrest system must have strength capable of sustaining static loads applied in all directions permitted by the system of at least:

- (a) Two times the maximum arrest force permitted on the system with certification, or
- (b) 5,000 lb. (22.2 KN) in the absence of certification.

When more than one personal fall arrest system is attached to the anchorage, the strength in (a) and (b) must be multiplied by the number of personal fall arrest systems attached to the anchorage.

3.Connection Compatibility Limitations

All equipment must be coupled to compatible connectors. OSHA 29 CFR 1926.502 prohibits snap hooks from being engaged to certain objects unless two requirements are met:

1. It must be a locking type snap hook.
2. It must be “designed for” making such a connection.
 - a. “Designed for” means that the manufacturer of the snap hook specifically created the snap hook to be used to connect to the equipment in question.

The following conditions can result in rollout * when a non-locking snap hook is used.

Avoid the following connections:

- Direct connection of a snap hook to horizontal lifeline.
- Two (or more) snap hooks connected to one D-ring.
- Two snap hooks connected to each other.
- A snap hook connected back on its integral lanyard.
- A snap hook connected to a webbing loop or webbing lanyard.
- Improper dimensions of the D-ring, rebar, or other connection point in relation to the snap hook dimensions that would allow the snap hook keeper to be depressed by a turning motion of the snap hook.



* Rollout: A process by which a snap hook or carabiner unintentionally disengages from another connector or object to which it is coupled.

4.Fall Clearance/Clear Fall Charts

Clearance Requirements

Image 1 shows a shock-absorbing lanyard anchored overhead with the other end connected to the dorsal D-ring of a full body harness. Note that the length of your shock-absorbing lanyard in relation to where it is attached is directly related to the amount of fall clearance that you will need. When using a shock-absorbing lanyard, include the following distances in your calculations:

Using the 6 Foot Shock-Absorbing Lanyard will require a total fall clearance of approximately 18 feet (5.5 meters) as measured from the anchorage point of lanyard to the nearest obstruction below. The total fall clearance combines the sum of the length of the lanyard, the maximum elongation of the lanyard (4 feet or 1.2 meters), the average distance between the worker’s dorsal D-ring (5 feet or 1.5 meters), and the safety factor (3 feet or 0.9 meters).

Using an extended free fall (12 foot) Shock Absorbing Lanyard will require a total fall clearance of approximately 20 feet (6.1 meters) when anchored at foot level and measured from the anchorage point of lanyard to the nearest obstruction below. The total fall clearance combines the sum of the length of the lanyard, free fall distance, the maximum elongation of the lanyard (5 feet or 1.5 meters), the average distance between the worker's dorsal D-ring, (5 feet or 1.5 meters), and the safety factor (3 feet or 0.9 meters).

Harness max stretch is less 18inch.

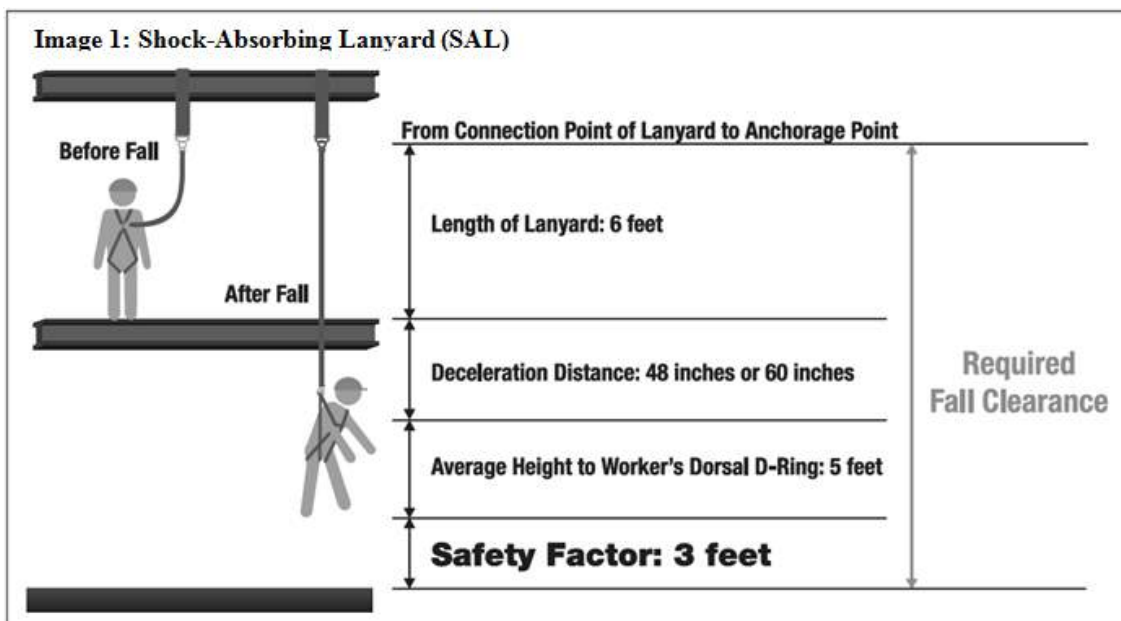

Swing Fall

To minimize the possibility of a swing fall, work as directly under the anchorage connector as possible. Striking objects horizontally, due to the pendulum effect, may cause serious injury. Swing falls also increase the vertical fall distance of a worker, compared to a fall directly below the anchorage connector. Swing falls may be reduced by using overhead anchorage connectors that move with the worker.

WARNING

Workers accessing areas greater than 30° off-plumb from overhead anchorage are at a higher risk for severe injury.

Striking objects horizontally due to the pendulum effect of a swing fall may cause serious injury or death.

Swing Fall

WARNING: Workers accessing areas greater than 30° off plumb from overhead anchorage are at a higher risk for severe injury.

The diagram shows a worker on a platform with an overhead anchorage point. The worker is shown swinging away from the vertical line of the anchorage, striking a vertical wall. The angle of the swing is indicated as being greater than 30 degrees off-plumb.

5. Donning



WARNING

Not all fall protection components are rated for the same user weight capacity. Only use components rated for the same weight capacity.

There must be a functional rescue plan if users of fall protection systems cannot rescue themselves.

Note: Sewn terminations should be secure, complete, and not visibly damaged. No load indicators shall be deployed. Damaged and other deteriorated and defective components must be immediately removed from service.

Fitting an Full Body Harness

Follow step from 1 to 7 for wearing harness.

Step 1: Hold the harness by the dorsal D-ring and shake to allow any tangled straps to fall into place.

Step 2: Unbuckle chest, leg and waist straps. If the harness has a belt, unbuckle it too.

Step 3: Slip the straps over the shoulders, so the back D-ring is located in the middle of the back between shoulder blades.

Step 4: Connect the chest strap and position in the mid chest area, then adjust shoulder straps with the two adjusters located at the lower end of the shoulder strap. Adjust the left and right sides to the same length.

Step 5: Pull the end of one leg strap between the legs and secure to the opposite end. Repeat this step with the other leg. If harness has a belt, connect that after the leg straps.

Step 6: After all the buckles have been connected, adjust so that the harness fits snug, but allows a full range of movement.

Step 7: Use the back D-ring or the front anchor point joined together by a connector as anchor point for fall arrest systems. To locate the anchor points on the harness, check for the "A" marking near them.

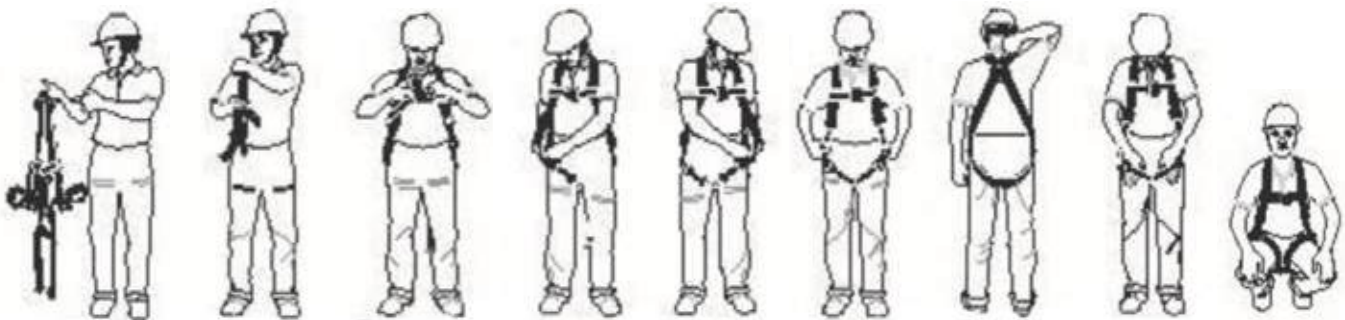

6. Training

Employers are responsible for providing training to any employee who may be exposed to fall hazards. Training will enable an employee to recognize and reduce fall hazards. Training must be conducted by a Competent or Qualified Person. Trainer and trainees must not be exposed to fall hazards during the training course.

7. Inspection

Frequency

Full Body Harnesses must be inspected prior to each use and every 6 months by a “Competent Person” other than the user.

To Inspect Webbing

Bend a portion of the webbing 6-8 inches into an upside-down ‘U’ shape. Continue along all webbing inspecting for tears, cuts, fraying, abrasion, discoloration, burns, holes, mold, pulled or broken stitches, or other signs of wear and damage.

Adjust all keepers, buckles, padding, and D-ring to inspect webbing hidden by these components.

Sewn terminations must be secure, complete, and not visibly damaged.

Check all buckles for damage, distortion, cracks, breaks, and rough or sharp edges. Inspect for any unusual wear, frayed or cut fibers, or broken stitching of the buckle attachments. Make sure buckles properly engage.

Ensure that the Quick-Connect buckle’s dual-tab release mechanism is free of debris and engages properly. Double-check the buckle locking mechanism by tugging on both halves of the buckle to make sure it is firmly connected and will not disengage.

All markings must be legible and attached to the product.

All hardware must be free of cracks, sharp edges, deformation, corrosion, or any evidence of defect.

8. Cleaning, Maintenance, and Storage

Cleaning

Full Body Harnesses can be wiped down with a mild detergent (e.g. Laundry) and wiped with a clean cloth to remove detergent. The hardware can also be wiped down with a clean, dry cloth to remove grease or dirt.

Maintenance

Any Full Body Harness requiring maintenance must be tagged “unusable” and removed from service.

Storage

- When not in use, Full Body Harnesses should be stored in a cool, dry place out of direct sunlight.
- Do not store in areas where damage from environmental factors such as heat, light, excessive moisture, oil, chemicals and their vapors, or other degrading elements may be present.
- Do not store damaged equipment or equipment in need of maintenance in the same area as product approved for use. Equipment must be cleaned and dried prior to storage.
- Equipment that has been stored for an extended period must be inspected as described in these *User Instructions* prior to use.

9. Labeling

All labeling must be legible and attached to the full body harness.

ANSI Z359.11-2021



**ANSI Z359 Recognizes the use of this harness only within the capacity range of :
130-310lbs.**

PART#:

Etiqueta No. 1/3 FRONTLINE <small>FALL PROTECTION</small>	DO NOT REMOVE THIS LABEL/NO quite esta Etiqueta		
	Model/Modelo:	XXXX	Capacity/Capacidad: (Included worker weight, clothing and tools) (Incluye ropa, herramienta y peso del usuario.) 130-310 Lbs.
	Material/Materiales:	Polyster/ Poliéster	
	Size/Tamaño:	XXXX	Free Fall Limit/Distancia Máxima de Caída Libre: (6 ft./1.8 m)/(6 pies/1.8mst)
	Date Made/Fecha Fabricación:	XXXX	
	Batch No.:	XXXX	Back D Ring/Argolla Espalda For Fall Arrest /Para La Detención de Caídas
	Serial No./Número Serie:	XXXX	For Positioning Only /Para Posicionamiento solamente
	Meets/Cumple:	ANSI Z359.11-2021 OSHA 1926 OSHA 1910	Hip D Rings/Argollas Laterales
Made In/Hecho en:	China	Chest D Ring/Argollas pecho For rescue & ladder climbing only /Para rescatar y Escala que sube sólo	

Etiqueta No. 2/3 FRONTLINE <small>FALL PROTECTION</small>	DO NOT REMOVE THIS LABEL/NO quite esta Etiqueta	
	WARNING/PRECAUCION:	
	<p>Read & heed all instructions in user manual supplied with harness. Remove from service if subjected to fall arrest. Failure to follow warnings and instructions can result in serious injury or death.</p> <p>Lea y siga todas las instrucciones del manual del usuario que acompaña al arnés. Retire de uso si ha sido sometido a la detención de una caída. El no seguir las advertencias e instrucciones puede producir lesiones graves o la muerte.</p>	

Etiqueta No. 3/3 FRONTLINE <small>FALL PROTECTION</small>	DO NOT REMOVE THIS LABEL/NO quite esta Etiqueta																																																																															
	Mark/Punch On Grip-Marque/Perfore en la Red.																																																																															
	1- Initial In Service Date/fecha Inicio Servicio.																																																																															
	2- Date Of Passed Inspection/Fecha de Inspección Aprobada.																																																																															
	3- Competent Person To Inspect Every Six Months.																																																																															
	4- Inspect Before Each Use / Inspeccione Antes De Cada Uso.																																																																															
	Punch/Perfore . 1 2 3																																																																															
	<table border="1" style="width: 100%; border-collapse: collapse;"> <thead> <tr> <th></th> <th>J</th> <th>F</th> <th>M</th> <th>A</th> <th>M</th> <th>J</th> <th>J</th> <th>A</th> <th>S</th> <th>O</th> <th>N</th> <th>D</th> </tr> </thead> <tbody> <tr> <td>2023</td> <td></td><td></td><td></td><td></td><td></td><td></td><td></td><td></td><td></td><td></td><td></td><td></td> </tr> <tr> <td>2024</td> <td></td><td></td><td></td><td></td><td></td><td></td><td></td><td></td><td></td><td></td><td></td><td></td> </tr> <tr> <td>2025</td> <td></td><td></td><td></td><td></td><td></td><td></td><td></td><td></td><td></td><td></td><td></td><td></td> </tr> <tr> <td>2026</td> <td></td><td></td><td></td><td></td><td></td><td></td><td></td><td></td><td></td><td></td><td></td><td></td> </tr> <tr> <td>2027</td> <td></td><td></td><td></td><td></td><td></td><td></td><td></td><td></td><td></td><td></td><td></td><td></td> </tr> </tbody> </table>		J	F	M	A	M	J	J	A	S	O	N	D	2023													2024													2025													2026													2027													
	J	F	M	A	M	J	J	A	S	O	N	D																																																																				
2023																																																																																
2024																																																																																
2025																																																																																
2026																																																																																
2027																																																																																

 <p>Dorsal Attachment</p>	 <p>Sternal Attachment</p>	 <p>Shoulder Attachment</p>
---	--	--

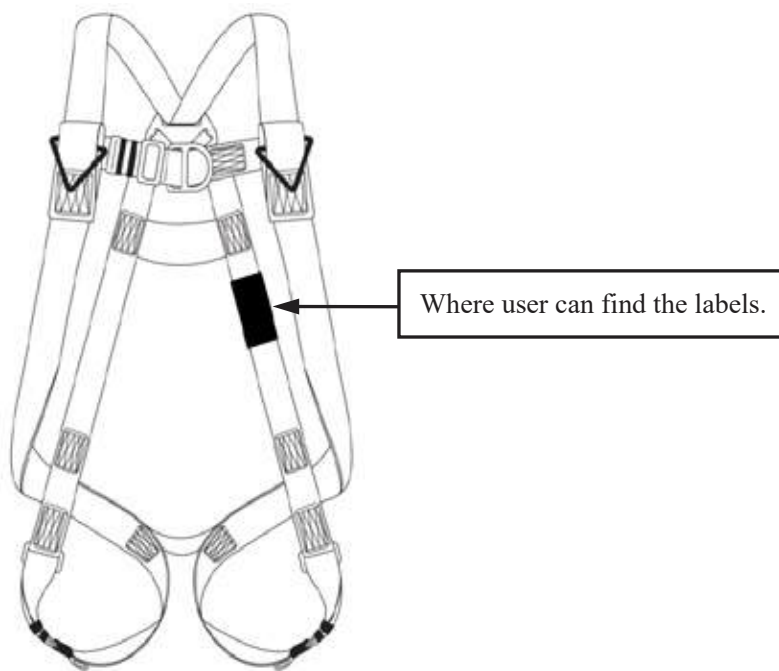
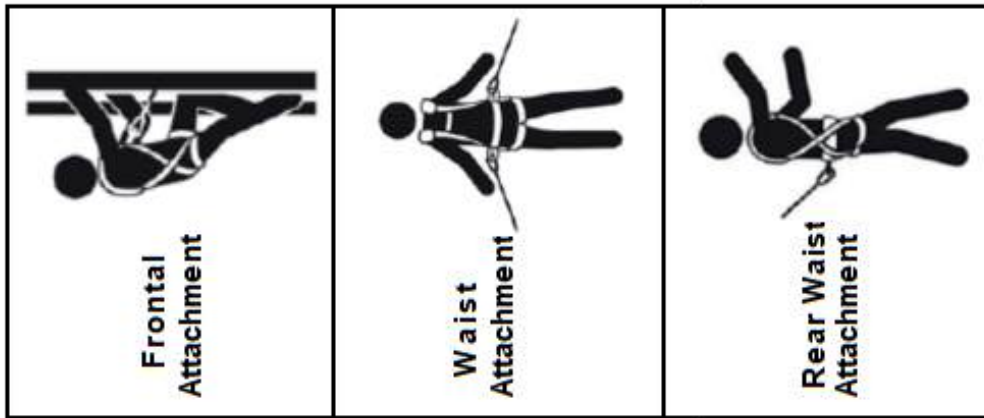

10. Annex A

Annex A – Normative

Note: This information from the ANSI Z359.11 standard is required to be included in the instruction manual for the end user:

ANSI/ASSE Z359 Requirements for Proper Use and Maintenance of Full Body Harnesses

(note: these are general requirements and information provided by ANSI/ASSE Z359, the manufacturer of this equipment may impose more stringent restrictions on the use of the products they manufacture, see the manufacturer's instructions.)

1. it is essential that the users of this type of equipment receive proper training and instruction, including detailed procedures for the safe use of such equipment in their work application. ANSI/ASSE Z359.2, *Minimum Requirements for a Comprehensive Managed Fall Protection Program*, establishes guidelines and requirements for an employer's managed fall protection program, including policies, duties and training; fall protection procedures; eliminating and controlling fall hazards; rescue procedures; incident investigations and evaluating program effectiveness.

2. Correct fit of a Full Body Harness is essential to proper performance. Users must be trained to select the size and maintain the fit of their Full Body Harness.

3. Users must follow manufacturer's instructions for proper fit and sizing, paying particular attention to ensure that buckles are connected and aligned correctly, leg straps and shoulder straps are kept snug at all times, chest straps are located in the middle chest area and leg straps are positioned and snug to avoid contact with the genitalia should a fall occur.

4. Full Body Harnesses which meet ANSI/ASSE Z359.11 are intended to be used with other components of a Personal fall Arrest system that limit maximum arrest forces to 1800 pounds (8 kn) or less.

5. Suspension intolerance, also called suspension trauma or orthostatic intolerance, is a serious condition that can be controlled with good harness design, prompt rescue and post fall suspension relief devices. A conscious user may deploy a suspension relief device allowing the user to remove tension from around the legs, freeing blood flow, which can delay the onset of suspension intolerance. An attachment element extender is not intended to be attached directly to an anchorage or anchorage connector for fall arrest. An energy absorber must be used to limit maximum arrest forces to 1800 pounds (8 kn). the length of the attachment element extender may affect free fall distances and free fall clearance calculations.

6. Full Body Harness (FBH) Stretch, the amount the FBH component of a personal fall arrest system will stretch and deform during a fall, can contribute to the overall elongation of the system in stopping a fall. It is important to include the increase in fall distance created by FBH Stretch, as well as the FBH connector length, the settling of the user's body in the FBH and all other contributing factors when calculating total clearance required for a particular fall arrest system.

7. When not in use, unused lanyard legs that are still attached to a Full Body Harness D-ring should not be attached to a work positioning element or any other structural element on the Full Body Harness unless deemed acceptable by the competent person and manufacturer of the lanyard. this is especially important when using some types of "y" style lanyards, as some load may be transmitted to the user through the unused lanyard leg if it is not able to release from the harness. the lanyard parking attachment is generally located in the sternal area to help reduce tripping and entanglement hazards.

8. Loose ends of straps can get caught in machinery or cause accidental disengagement of an adjuster. All Full Body Harnesses shall include keepers or other components which serve to control the loose ends of straps.

9. Due to the nature of soft loop connections, it is recommended that soft loop attachments only be used to connect with other soft loops or carabiners. Snaphooks should not be used unless approved for the application by the manufacturer.

Sections 10-16 provide additional information concerning the location and use of various attachments that may be provided on this FBH.

10. Dorsal – the dorsal attachment element shall be used as the primary fall arrest attachment, unless the application allows the use of an alternate attachment. the dorsal attachment may also be used for travel restraint or rescue. When supported by the dorsal attachment during a fall, the design of the Full Body Harness shall direct load through the shoulder straps supporting the user, and around the thighs. Supporting the user, post fall, by the dorsal attachment will result in an upright body position with a slight lean to the front with some slight pressure to the lower chest. considerations should be made when choosing a sliding versus fixed dorsal attachment element. Sliding dorsal attachments are generally easier to adjust to different user sizes, and allow a more vertical rest position post fall, but can increase FBH Stretch.

11. Sternal – the sternal attachment may be used as an alternative fall arrest attachment in applications where the dorsal attachment is determined to be inappropriate by a competent person, and where there is no chance to fall in a direction other than feet first. Accepted practical uses for a sternal attachment include, but are not limited to, ladder climbing with a guided type fall arrester, ladder climbing with an overhead self-retracting lifeline for fall arrest, work positioning and rope access. the sternal attachment may also be used for travel restraint or rescue. When supported by the sternal attachment during a fall, the design of the Full Body Harness shall direct load through the shoulder straps supporting the user, and around the thighs. Supporting the user, post fall, by the sternal attachment will result in roughly a sitting or cradled body position with weight concentrated on the thighs, buttocks and lower back. Supporting the user during work positioning by this sternal attachment will result in an approximate upright body position. If the sternal attachment is used for fall arrest, the competent person evaluating the application should take measures to ensure that a fall can only occur feet first. This may include limiting the allowable free fall distance. it may be possible for a sternal attachment incorporated into an adjustable style chest strap to cause the chest strap to slide up and possibly choke the user during a fall, extraction, suspension, etc. The competent person should consider Full Body Harness models with a fixed sternal attachment for these applications.

12. Frontal – the frontal attachment serves as a ladder climbing connection for guided type fall arresters where there is no chance to fall in a direction other than feet first, or may be used for work positioning. Supporting the user, post fall or during work positioning, by the frontal attachment will result in a sitting body position, with the upper torso upright, with weight concentrated on the thighs and buttocks. When supported by the frontal attachment the design of the Full Body Harness shall direct load directly around the thighs and under the buttocks by means of the sub-pelvic strap. If the frontal attachment is used

for fall arrest, the competent person evaluating the application should take measures to ensure that a fall can only occur feet first. This may include limiting the allowable free fall distance.

13. Shoulder – the shoulder attachment elements shall be used as a pair, and are an acceptable attachment for rescue and entry/retrieval. the shoulder attachment elements shall not be used for fall arrest. it is recommended that the shoulder attachment elements be used in conjunction with a yoke which incorporates a spreader element to keep the Full Body Harness shoulder straps separate.

14. Waist, Rear – the waist, rear attachment shall be used solely for travel restraint. the waist, rear attachment element shall not be used for fall arrest. Under no circumstances is it acceptable to use the waist, rear attachment for purposes other than travel restraint. the waist, rear attachment shall only be subjected to minimal loading through the waist of the user, and shall never be used to support the full weight of the user.

15. Hip – the hip attachment elements shall be used as a pair, and shall be used solely for work positioning. the hip attachment elements shall not be used for fall arrest. Hip attachments are often used for work positioning by arborists, utility workers climbing poles and construction workers tying rebar and climbing on form walls. Users are cautioned against using the hip attachment elements (or any other rigid point on the Full Body Harness) to store the unused end of a fall arrest lanyard, as this may cause a tripping hazard, or, in the case multiple leg lanyards, could cause adverse loading to the Full Body Harness and the wearer through the unused portion of the lanyard.

16. Suspension seat – the suspension seat attachment elements shall be used as a pair, and shall be used solely for work positioning. the suspension seat attachment elements shall not be used for fall arrest. Suspension seat attachments are often used for prolonged work activities where the user is suspended, allowing the user to sit on the suspension seat formed between the two attachment elements. An example of this use would be window washers on large buildings.

USER INSPECTION, MAINTENANCE AND STORAGE OF EQUIPMENT

Users of personal fall arrest systems shall, at a minimum, comply with all manufacturer instructions regarding the inspection, maintenance and storage of the equipment. the user's organization shall retain the manufacturer's instructions and make them readily available to all users. See ANSI/ASSE Z359.2, *Minimum Requirements for a Comprehensive Managed Fall Protection Program*, regarding user inspection, maintenance and storage of equipment.

1. in addition to the inspection requirements set forth in the manufacturer's instructions, the equipment shall be inspected by the user before each use and, additionally, by a competent person, other than the user, at interval of no more than one year for:

- **Absence** or illegibility of markings.
- **Absence** of any elements affecting the equipment form, fit or function.
- **Evidence** of defects in, or damage to, hardware elements including cracks, sharp edges, deformation, corrosion, chemical attack, excessive heating, alteration and excessive wear.
- **Evidence** of defects in or damage to strap or ropes including fraying, unsplicing, unlaying, kinking, knotting, roping, broken or pulled stitches, excessive elongation, chemical attack, excessive soiling, abrasion, alteration, needed or excessive lubrication, excessive aging and excessive wear.

2. inspection criteria for the equipment shall be set by the user's organization. Such criteria for the equipment shall equal or exceed the criteria established by this standard or the manufacturer's instructions, whichever is greater.

3. When inspection reveals defects in, damage to, or inadequate maintenance of equipment, the equipment shall be permanently removed from service or undergo adequate corrective maintenance, by the original equipment manufacturer or their designate, before return to service.

Maintenance and Storage

1. maintenance and storage of equipment shall be conducted by the user's organization in accordance with the manufacturer's instructions. Unique issues, which may arise due to conditions of use, shall be addressed with the manufacturer.

2. equipment which is in need of, or scheduled for, maintenance shall be tagged as unusable and removed from service.

3. equipment shall be stored in a manner as to preclude damage from environmental factors such as temperature, light, UV, excessive moisture, oil, chemicals and their vapors or other degrading elements.

Notes

If equipment fails inspection **IMMEDIATELY REMOVE FROM SERVICE**.

User must inspect prior to **EACH** use.

Competent Person must do complete formal inspection at least 1 time per 6 month period.

Competent Person has to inspect and initial. Date of first use: _____.

Product lifetime is 5 years as long as it passes pre-use and Competent Person inspections. **REMOVE FROM SERVICE** 5 years after date of first use, or, if not recorded, from date of manufacture. All inspection records must be made visible and available to all users at all times.

11. Checking Card

Checking Card				
Reference		Serial number		
Year of manufacture		Date of purchase		
User name				
Inspection Record				
Date	Reason for entry (periodic examination or repair)	Competent person name + signature	Comments	Next Due date for periodic examination
Manufacturer: Frontline Fall Protection Inc. 2111 NW 84 th Ave, Miami, Florida 33122, U.S.A.			Web: www.frontlinefall.com Email: info@frontlinefall.com	



User Instructions of Vertical Lifeline

Comply with ANSI Z359.15-2014

Manufacturer:

Frontline Fall Protection Inc.
2111 NW 84th Ave, Miami, Florida 33122, U.S.A
Web: www.frontlinefall.com
E-mail: info@frontlinefall.com



WARNING:

- These instructions must be provided to the end user of this product.
- It is the responsibility of the user to read and understand these instructions before using this equipment or to have them explained. Failure to do so could result in serious injury or death.
- Certified fall protection and product training is highly recommended before using this equipment and may be required by local Occupational Health and Safety Regulations.
- Any alteration or misuse of this product is forbidden and may result in serious injury or death.
- Only Frontline, or entities authorized in writing by Frontline, shall make repairs or alterations to the equipment.
- Only use components rated for the same weight capacity. Not all fall protection components are rated for the same user weight capacity.
- Only use combinations of fall arresters, lanyards, and lifelines approved by the manufacturer, affect or interfere with the safe function of each other may result in serious injury or death.
- Proper precautions should always be taken to remove any obstructions, debris, material, or other recognized hazards from the work area that could cause injuries or interfere with the effective operation of the system.
- Do not use this equipment around moving machinery and electrical hazards.
- Protect all synthetic materials from slag, hot sparks, open flames and other wear and tear.
- Do not expose equipment to environmental hazards and chemicals which may produce a harmful effect.
- Do not allow equipment to come in contact with anything that will damage it including: sharp edges, abrasive surfaces, or high-temperature applications like welding, heat sources, and electrical areas.
- Evaluate space below work area to ensure potential fall path is clear of obstructions.
- Allow adequate fall clearance below the work surface.
- Do not expose the equipment to any hazard which it is not designed to withstand. Consult Frontline in cases of doubt.

Workplace

Your workplace should be assessed for the following hazards: heat, flames, chemicals, electrical, environmental, sharp objects, unstable/uneven or slippery surfaces or moving equipment. Identify the potential hazards and plan the installation of the lifelines to avert dangerous areas, zones and obstructions. Always have an emergency rescue plan in the event that an accident occurs.

Components

Vertical Lifelines (VLP25R3L-VLP200R3L) are twisted rope with one eye termination and made of the following three parts:

Energy absorbing lanyard (RGSU58ES) + Rope Grab (RGSS58) + Lifeline (VLP25-200)

Instructions of LANYARD

The Energy Absorbing Lanyard (RGSU58ES) shall be used in combination with the Rope Grab (RGSS58) and the lifeline (VLP25-200).

1. Application and Usage

A complete Personal Fall Arrest System (PFAS) is constructed from the following 3 components:

Anchor Point - This is described as a secure point of attachment for attaching your connecting device. The anchor point can also be referred to as the “tie-off” point. This anchor point must be capable of supporting 5,000lbf (22.5kN) per worker. Recommended anchor points consist of an I-beam or other support structure. They should never consist of mobile devices or guard rail systems.

Body Wear - This equipment is worn by the worker while performing the job. This could be described as any of the following; full body harness, positioning belt, or body belts. Each piece of equipment is used in different applications of fall arrest. A full body harness must be used for all fall arrest systems.

Connecting Device - The connecting device can be any of the following: a shock absorbing lanyard, an energy absorbing lanyard, or a self-retracting lifeline. If you are using a rope, web, or cable lanyard then they MUST be used in conjunction with a shock absorber.

2. PERSONAL FALL ARREST SYSTEM (PFAS) COMPONENT WARNINGS AND

LIMITATIONS

2.1 Anchor Point

- Each PFAS must be anchored to a suitable structure capable of resisting a static load of 3600 lbf (16 kN) if certified, or 5000 lbf (22.5 kN) if not certified; per employee attached. If more than one PFAS is anchored to the structure, the structure must be capable of resisting static loads equal to the above values multiplied by the number of PFAS's attached to it.
- Anchorage must be solid, rigid, and stable. Do not anchor to flexible structures or to mobile structures that could overturn when subjected to a fall. It is recommended that a professional engineer certify any anchorage on a mobile structure, and a strict lockout procedure must be in place to prevent unintentional operation/movement of the mobile structure.
- Ensure that the anchorage point is at a height that will not allow the worker to strike an object or ground in the case of a fall.
- User must also allow for 4.0ft. (1.22m) extension distance beyond the stated length of a shock absorbing lanyard.
- Ensure the anchorage point is at a height that limits the free fall distance to 6.0 ft.(1.83m) or less. However, local regulations may limit the maximum free fall distance to a lower value. Always consult with your regulatory requirements.
- Never use an anchorage that will not allow a snap hook or carabiner keeper to close.
- Always select an anchorage that is located above the user's harness attachment point. Do not work above the anchorage level as this increases free fall. Work as directly below the anchorage as possible to minimize swing fall hazards. Do not work more than 30 degree from the anchorage.
- Working directly under the anchorage point will prevent a swing-fall injury.
- The force of striking an object while swinging can be severe and may result in serious injury or death.

2.2 Body Wear

- Fall arrest equipment should be inspected before each use and be checked by a competent individual on a regular basis.
- Fall protection equipment should be attached to the back D-ring of a full body harness. If need be, a front D-ring may be used for fall arrest in rescue, work positioning, rope access, and other ANSI Z359.1 recognized applications only if the system is limited to a maximum free fall distance of 2 ft. (0.6m) and limited to a maximum arrest force of 900 lbf (4.0kN).
- Never attach non-locking snap hooks to a harness D-ring.

2.3 Connecting Devices

The lanyard connectors (snap hooks) must be compatible with the anchorage, or anchorage connector in terms of size, shape, and strength. Non-compatible connectors may unintentionally disengage (roll-out). The snap hook keeper must fully close and lock. Avoid any connection that will result in loading the gate of the snap hook.

- Make only compatible connections
- Shock absorbers can elongate up to 4 ft. (1.2m). The maximum elongation distance must be considered when determining your anchorage point.
- Use only connecting devices that contain a snap hook or auto-locking carabiner.
- Snap hooks and carabiners shall not be connected to each other unless specifically designed for such connections.
- Always visually check that the snap hook or carabiner freely engages the D-ring, and anchor point, and that the keeper is completely closed and locked.
- Shock absorbers are required to reduce the fall arrest force if a fall takes place.
- The lanyards are constructed from a nylon core with a nylon cover and limit the fall arrest force to 900 lbf (4kN).
- Rig lanyard to allow a maximum free fall distance of not more than 6 ft. (1.8m) User must also allow 4 ft. (1.2m) extension distance beyond the stated length of the lanyard.
- Do not allow lanyard to contact sharp, or abrasive surfaces, sparks, or temperature above 180°F.
- Snap hooks with gate openings larger than one inch (1") must not be connected to D-rings on body harnesses or belts.

Warnings

- Never alter the connecting device in any shape, way or form. This can cause serious injury or even death.
- Never reduce the length of a lanyard by creating a knot.
- Never attempt to increase the length of the lanyard by joining two lanyards together.
- Never allow a retractable lanyard or lifeline to become slack.
- Never allow the lanyard to wrap around the users neck, arms, legs or other obstacle
- Never remove important labels which include information for authorized or competent individuals.

3.0 CAPACITY

Shock absorbing lanyards are limited to one person only with a maximum total combined weight of 310 lbs including tools and equipment.

4.0 MAXIMUM FREE FALL

Maximum free fall (MFF) distance must be no greater than 6ft, however, local regulations may limit the MFF to a lower value. Consult your local regulatory requirements.

5.0 MAXIMUM ARREST FORCE

Shock absorbing lanyards have a maximum arrest force of 900 lbf (4kN) when tested in accordance with the applicable ANSI standards. The average arresting force (Favg) is 2.0kN and cannot be less based on the ambient dry conditions.

6.0 MAXIMUM ELONGATION

The maximum permanent elongation of a shock absorbing lanyard is 6ft (1.83.m) when fully deployed.

7.0 LANYARD LENGTH

Select a shock absorbing lanyard with the proper length for intended application. Do not join two lanyards together or use knots as a means to adjust lanyard length. If you are unsure as to the length of lanyard required for your application, consult the supplier or a trained competent / qualified person for assistance in selecting the proper lanyard.

8.0 ENVIRONMENTAL HAZARDS

Avoid use near sharp edges, abrasive surfaces, moving machinery, and electrical hazards.

Avoid exposure to harmful chemicals, heat, and direct sunlight (UV rays).

9.0 AFTER A FALL

After a fall, the fall indicator tag will be visible and the shock absorbing lanyard must be immediately removed from service and destroyed.

10.0 RESCUE

It is the responsibility of the user and purchaser of this lanyard to ensure that a rescue plan is in place to immediately detect and safely retrieve a fallen worker. Please contact the supplier or a trained professional if you require assistance in formulating a rescue plan.

11.0 INSPECTION

Before each use visually inspect the entire lanyard for any obvious signs of damage, deterioration or distress. Inspect webbing for frayed, cut, or broken fibers. Check for tears, abrasion, burns, discoloration, kinking, knotting, roping, excessive soiling, needed or excessive lubrication and excessive aging.

- Inspect for broken stitches or pulled thread.
- Inspect ID label to ensure that it is present and fully legible.
- Inspect equipment for evidence of defects in or damage to hardware elements including cracks, sharp edges, deformation, chemical attack, excessive heating, alteration, and excessive wear.
- Measure the length of the lanyard, ensure it matches the initial length indicated on the label +/- 1 in. If length is greater than initial length, it may have been subjected to fall arrest forces, remove from service and destroy. If inspection reveals any of the above conditions the lanyard must be immediately removed from service and destroyed. If in doubt about safety or condition of the unit, have it inspected by a competent/qualified person or return it to supplier or authorized agent for a detailed inspection.
- Inspect all other components of the fall arrest system according to suppliers instructions. Before using any fall arrest system ensure that a rescue plan is in place to immediately detect and to safely retrieve a fallen worker.

Instructions of ROPE GRAB

The Rope Grab (RGSS58) shall be used in combination with the Energy Absorbing Lanyard (RGSU58ES) and the lifeline (VLP25-200).

1.0 DESCRIPTION

This rope grab is constructed of a long-wearing non-corrosive stainless steel, brass and bronze material. Inspected for reliability in material, construction and function, it meets applicable ANSI requirements. A permanently attached 3 ft. (0.9m) lanyard certified to meet ANSI Z359.15-2014 standards when used with polyester or nylon 5/8 in.(16mm) rope and when properly installed and maintained. The capacity is 130-310 Lbs, including equipment.

2.0 INTENDED PURPOSE

A rope grab is a deceleration device which travels on a lifeline. The rope grab automatically engages the lifeline and locks to arrest the fall of an individual. Sewing through the webbing between the rope grab and energy absorbing lanyard which absorbs the energy of a fall when attached to a full body harness.

NOTE: This rope grab is to be used as part of a complete personal fall protection system. Any other components, subsystems or connectors used with or attached to the rope grab should be supplied by PALOMA and be compatible and meet the correct ANSI requirements for the application. Components that are substandard or not approved could compromise the reliability of the system and put the safety of the user at risk. These instructions are not an appropriate substitute for a proper climbing and fall arrest training program but are intended to inform the user on care and use of this rope grab. Users must be completely trained in and familiar with all regulations that apply to the workplace in which the fall arrest equipment is being used. If you need clarification on any of the regulations, contact your local ANSI office. Information regarding local circumstances, rules and regulations that apply to the work situation, an opportunity to learn hands-on how to wear and attach the equipment properly should be included in the training program.

3.0 BEFORE EACH USE

Open and inspect unit. Ensure all parts are free of dirt and debris. Inspect components for damage or wear that may restrict the movement and/or effectiveness of the mechanism. If the condition of the equipment is in doubt, do not use.

- PALOMA does not authorize repairs, therefore repairs shall not be made to this equipment.
- The locking screw should easily thread and tighten against the body with body parts touching.
- The locking clip should easily rotate and pass over the detent and into the notch of the body with resistance sufficient enough to hold it in a locked position.
- To ensure the gripping mechanism is functioning properly, pivot the ring and gripper back and forth. The spring resistance should be noticeable and the movement should be smooth, without binding.
- While the tension roller is in it's slot under spring tension, it should rotate and move freely.
- All other workings of the fall protection system used with this rope grab should be inspected as per the manufacturer' s instructions and ANSI guidelines.
- Inspection results should be recorded and kept on file.
- This fall arrest system should be immediately discarded if the product has been involved in a fall arrest. Additionally, items which have failed inspection should be removed from service. Those items which have failed due to excessive wear and tear, damage, or malfunction should be discarded.

4.0 STORAGE

- This equipment should be stored in a cool, dry environment away from direct sunlight.

5.0 INSTALLATION AND USE

- Pivot the locking clip away from the body and then turn the locking screw counter-clockwise until it is disengaged. The rope grab can now be pivoted open. Inspect as previously outlined.
- When the rope grab is positioned properly, the arrow will be facing up. (The roller attached to the hinge pin will be pointing down.)
- Lifeline can now be inserted. Only 5/8 in. (16mm) diameter rope should be used.
- Pivot the ring until the gripper does not press against the rope, then close the unit around the rope.
- Tighten the locking screw, it should thread easily and tighten against the rope grab body. The body parts should be touching. Rotate the locking clip over the dimple into the notch in the body. The locking clip should rotate easily and stay in the locked position with the help of the detent and bronze thrust washer.
- Test mobility: This rope grab is designed to work with minimum effort. To move upward, pull up on the ring, it should move easily. To move downward, lift up on the ring to release the gripper. The weight of the unit should move it downwards. To ensure you have proper freedom of movement, repeat the above steps.
- To test the installation, pull down sharply on the ring. The mechanism will lock onto the rope if it is functioning properly.

6.0 MAINTENANCE

- To clean, use water and a mild soap. Wipe dry with a clean cloth or use low-pressure compressed air.
- To lubricate, use light oil such as WD-40. A small amount of oil can be used on pivot and roller bearing points. Take care to remove any excess oil from the body and surfaces of the rollers to ensure no transfer of oil to the rope.

7.0 WARNING

When in use, do not manipulate or hold the fall arrester body or lever. If the user should fall while holding the rope grab, they could restrict the locking mechanism. This would prevent the device from arresting the fall. Serious injury or death could result. Maintain the lever of the fall arrester is forced upward by lanyard, the fall arrester will be able to move freely up/down on the lifeline.

- Rope grabs are designed to be attached to no more than one lifeline.
- Rope grabs are designed to be a part of a fall arrest system for one person with a maximum weight (equipment and person) of 310 lbs.
- Make sure your path is free and clear of obstructions and hazards and that the rope grab does not come in contact with any outside objects when in use.
- To minimize falling distance, position the rope grab above the user on the lifeline.
- Rope grabs should be removed from service and discarded once it is subject to a fall.
- After each use, the rope grab should be inspected as mentioned above, then cleaned and stored.
- Avoid exposure to chemical substances or hazards which the fall arrester is not designed to withstand; failing to do so may result in compromising the material, allowing for the potential of personal injury or death.
- This product is neither intended for, nor is it suitable for use when the user is positioned on an unstable surface such as fine grain materials or particulates.

- Users shall not alter the equipment, doing so may result in serious death or injury.
- Care should be taken when using equipment near machines and electrical hazards.
- Contact should be avoided with sharp edges and abrasive surfaces.

Instructions of LIFELINE

The Lifeline (VLP25-200) shall be used in combination with the Rope Grab (RGSS58) and the Energy Absorbing Lanyard (RGSU58ES).

1.0 INTENDED PURPOSE

A lifeline is a component of a complete fall arrest system consisting of a flexible lifeline which is fed through a rope grab. The rope grab travels along the vertical line which locks into the flexible line when it is subjected to a fall or travels along the line quickly. The lifeline is also connected to an anchorage point. Any other components, subsystems or connectors used with this lifeline should be supplied by PALOMA and meet the applicable ANSI regulations.

2.0 SIZE

A 5/8 in. (16mm) diameter three-strand lifeline. Rope that is smaller than 5/8" in diameter may not allow the rope grab to lock properly and may cause an excessive stopping distance. Rope that is larger than 5/8" in diameter will reduce mobility.

3.0 TYPE

It is recommended to use ropes made from polyester fibers as they stretch less due to moisture absorption than nylon fibers. Ropes made entirely of polypropylene, polyethylene or other olefins are not to be used. It is not advised to use ropes made from cotton, sisal, hemp, manila or other plant fibers. Kernmantle rope is not recommended.

4.0 PERFORMANCE

- Breaking strength : 5000 lbf (22.5 kN)
- Elongation : 8% Dry / 10% Wet
- Melting point : 220 °C
- Capacity : 130-310 Lbs including equipment

5.0 WARNING

- Only use one fall arrester be attached to the single anchor lifeline.
- Only one user can be attached to the single anchor lifeline.
- Do not allow lifeline to come in contact with anything that will damage it including: sharp edges, abrasive surfaces, environmental hazards and chemicals, moving machinery or high-temperature applications like welding, heat sources, and electrical areas.
- A lifeline may no longer have its rated strength and should be replaced if it is "fluffed" by wear and/or is discolored to black in the interior of the strands.
- To minimize the possibility of a swing fall, work as directly under the anchorage connector as possible. Striking objects horizontally, due to the pendulum effect, may cause serious injury. Swing falls also increase the vertical fall distance of a worker, compared to a fall directly below the anchorage connector. Swing falls may be reduced by using overhead anchorage connectors that move with the worker.

- Only Frontline, or entities authorized in writing by Frontline, shall make repairs or alterations to the equipment.

6.0 INSPECTION

- It is the end-users responsibility to ensure that the anchorage point provides adequate protection to handle maximum load protection. Anchor points should be capable of supporting 5000 blf (22.5 kN) per worker and also should be above the worker to avoid a pendulum fall.
- This unit meets ANSI Z359.15-2014 regulations. The user shall understand and adhere to applicable governing occupational safety standards and/or regulations.
- The arresting distance for the vertical life line shall not exceed 3ft.
- The end of the lifeline must have stopper knot to prevent the fall arrester inadvertently traveling off the lifeline.
- A lifeline should be immediately discarded if the product has been involved in a fall arrest. Additionally, items which have failed due to excessive wear and tear, damage, or malfunction should be discarded.
- All users or companies should have a developed rescue plan in place and the means to implement such a plan when using the equipment.
- Misusing the equipment by not following the manufacturer's instructions may result in serious injury or death.
- Avoid exposure of this until to chemical substances, such as acids, bases, caustic. Failure to do so may result in compromising the material and allowing for the potential of personal injury or death.
- The vertical lifeline should be held taut by attaching a 6 to 10 lb. weight or by securing the lifeline from below to allow for free trailing movement of the rope grab. Job site conditions and trained personnel should determine the safest method of securing the lifeline.
- Users shall not alter the equipment, doing so may result in serious death or injury.

7.0 CLEANING & MAINTENANCE

The lifeline should be stored in a cool, dry environment away from direct sunlight. To clean product wipe down with a damp sponge. The use of a mild soap solution can be used for stubborn dirt and/or debris.

NOTE: Refer to ANSI Z359.15-2014 standards regulating lifelines.

8.0 CALCULATING TOTAL FALL CLEARANCE DISTANCE

Rope grab systems are designed to travel approximately 3ft (0.9m) during a fall as well, the energy absorber is designed to extend 4ft (1.2m) during a fall. This helps to reduce the fall arrest force, which will lower the injury threshold. It is important to understand this extension known as the "Deceleration Distance" when calculating the total fall clearance distance to avoid contact with a lower level.

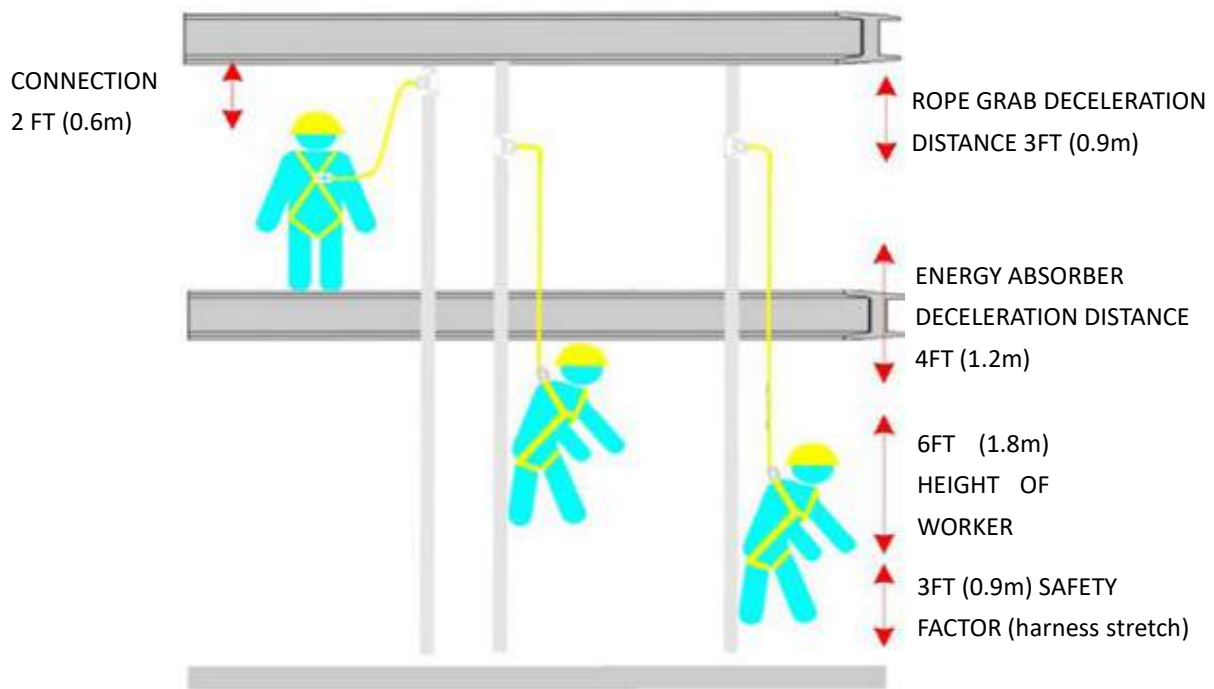

1. When using a full body harness and a rope grab system, you must add the connector length **2ft (0.6m)** to the deceleration distance of rope grab **3ft (0.9m)** to deceleration distance of energy absorber **4ft (1.2m)** to the height of the worker (**6ft/1.8m** average height).
2. Add an additional **3ft (0.9m)** to the total as safety clearance including harness stretch.
3. Total is **18ft (5.4m)**. This is the estimated height that you must attach your anchorage to reduce the risk of coming in contact with the lower level. This is the safe fall clearance distance.
4. Arresting distance for the vertical lifeline is not to exceed 3ft.

WARNING: Before using the lifeline, calculate your fall distance and select the proper equipment to meet estimated fall clearance. Failure to select proper equipment and calculate fall distances may result in serious personal injury, illness or death.

Care should be taken when joining the complete fall arrest system together. The following steps should be followed:

1. Fit a harness.
2. Attach the snap hook from the lifeline (rope) to the anchorage point. (Warning: ensure anchorage point can support 5000 lbf or 22.5 kN).
3. Attach the snap hook from the lanyard/rope grab combo to attachment D-ring of the harness.
4. Unlock rope grab, by unlocking safety and then turning knob counter clockwise until unit opens.
5. With the arrow(s) point towards the anchorage point, insert lifeline.
6. Secure lifeline by closing hinge, turning knob clockwise until securely in place, close safety.

NOTE:

To ensure a correct connection has been made, it should be noted that the lifeline will **ONLY** travel towards the anchorage point. To test this move the lanyard back and forth a few inches to ensure a correct connection. If the lifeline travels in the opposite direction the lifeline may have been position incorrectly into the rope grab. Disassemble and return to step 5 and follow through until step 6.

LABELLING

All labels shall be clearly, indelibly and permanently marked on the product.

Label 1



Label 2



Label 3 (Inside of the energy absorber)



Label 4

DO NOT REMOVE THIS LABEL			
FRONTLINE® FALL PROTECTION	Model:	VLP00	Rope Grab: RGS558
	Material:	Poly blend rope made from nylon	Diameter: 5/8 in
	Date Made:	MM/YYYY	Length: XX FT
	Batch No.:	XXXX	Min Breaking Strength: 5000 lbf (22.5kN)
	Serial No.:	XXXX	Capacity: 130-310 Lbs including Equipment
	Meets:	ANSI Z359.15-2014	
	Made In:	CHINA	

Label 5

THIS LABEL ONLY FOR FALL ARRESTER			
FRONTLINE® FALL PROTECTION	Model:	RGSU58ES	Component: Snap Hook+Energy Absorber+Rope Grab
	Length:	1.5 FT	Rope Size: 5/8 in. three-strand
	Serial No.:	XXXX	Capacity: 130-310 lbs including equipment
	Date of Mfg:	MM/YYYY	Meets: ANSI Z359.15-2014
Avoid contact with sharp edges and abrasive surfaces Only make compatible connections Only use safety lanyards approved by the manufacturer			

Label 6

DO NOT REMOVE THIS LABEL														
WARNING 1. Refer to manufacturer's instructions for proper operation, inspection and cleaning. Failure to do so could result in serious injury or death. 2. Avoid contact with sharp edges and abrasive surfaces. 3. Inspect before each use, and at least every 6 months.		J	F	M	A	M	J	J	A	S	O	N	D	
	2021													
	2022													
	2023													
	2024													
	2025													

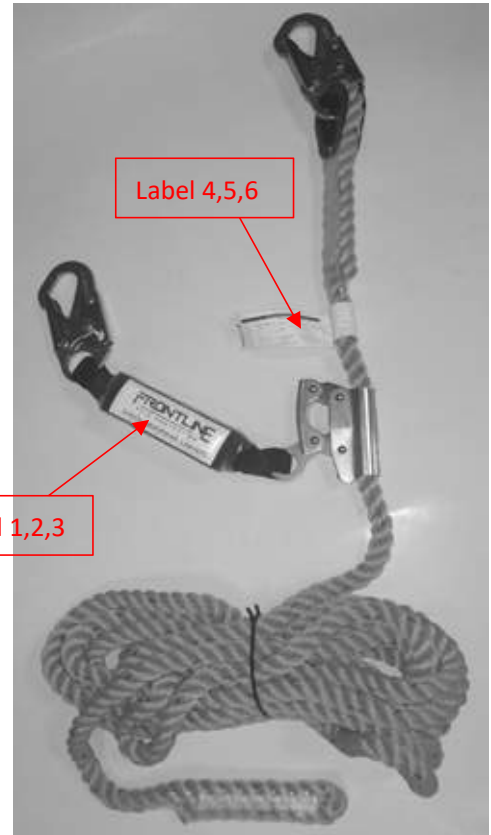

Checking Card				
Equipment Record				
Reference				
Serial number				
Year of manufacture				
Date of purchase				
Date of first put into operation				
User name				
Comments				
Inspection Record				
Date	Reason for entry (periodic examination or repair)	Competent person name + signature	Comments	Next Due date for periodic examination

Manufacturer:

Frontline Fall Protection Inc.
 2111 NW 84th Ave, Miami, Florida 33122, U.S.A
 Web: www.frontlinefall.com
 E-mail: info@frontlinefall.com



USER INSTRUCTIONS

For

ROOF ANCHOR

Comply with *ANSI Z359.18-2017*

THIS INSTRUCTIONS APPLY TO FOLLOWING MODELS:

RO01 ...

Table of Contents

WARNING	Page 3
1. Limitations for Use	Page 3
2. Connection Compatibility Limitations.....	Page 4
3. Performance.....	Page 5
4. Loading Direction Limitation.....	Page 5
5. Installation.....	Page 6
6. Training.....	Page 7
7. Inspection.....	Page 7
8. Cleaning, Maintenance and Storage.....	Page 7
9. Labeling.....	Page 8
10. Checking Card.....	Page 8

Warning

- Current User Instructions must always be available to the user.
- Read and understand this instructions before using this equipment.
- This User Instructions is not to be removed except by the user of this equipment.
- User must read and fully understand the limitations and proper use of this equipment.
- Do not alter, relocate or add to this equipment without manufacturer's authorization.
- Misuse or failure to follow warnings, instructions and limitations on the use of this equipment may result in serious personal injury or death.
- Do not use this equipment if you are unable to tolerate the impact of a fall arrest.
- Age and fitness can seriously affect your ability to withstand a fall. Consult with **Frontline** if in doubt.
- Minors, pregnant women and anyone with a history of back and/or neck problems must not use this equipment.
- Remove any surface contamination that could accelerate cutting or abrading of attached components, such as concrete, stucco, roofing material, etc.
- Do not concerning environments and conditions that may degrade this equipment, such as sharp edges, abrasive surfaces, moving machines, high-temperature applications (like welding), electrical hazards and chemical hazards.
- Inspect Personal Fall Arrest System (PFAS) equipment for wear, damage and other deterioration prior to each use.
- Defective components must be removed from service immediately.
- Never remove product labeling because it include important information for the ANSI standard.

1. Limitations for Use

- This equipment is designed to be used in temperatures ranging from -40°F to +130°F (-40°C to +54°C).
- This equipment is designed for use by one person only, with maximum weight of 310 lbs (140 kg) if used in combination with equipment explicitly certified for such sue (including clothing, tools, etc.,).
- This equipment must only be used on structures capable of supporting static loads applied in all directions permitted by the fall arrest system of at least 5,000 lbs (22.2 kN).
- Thoroughly evaluate and plan all elements of fall protection systems before using this equipment. Make sure that your PFAS is appropriate for your needs and facility. Users must have a rescue plan and the means to implement it. This plan must provide prompt employee rescue or ensure that employees have the ability to rescue themselves in the event of a fall.
- This equipment must be removed from service immediately if a fall is incurred.
- To minimize the potential for accidental disengagement, a Competent Person must ensure system compatibility.
- Repairs must be performed only by manufacturer, or persons or entities authorized in writing by the manufacturer.
- All equipment must be inspected before each use according to the manufacturer's instructions. All equipment should be inspected by a qualified person on a regular basis.
- Never use fall protection equipment for purposes other than those for which it was designed.
- Components must not be used for any other operation other than that which it has been designed and approved.
- Fall Restraint System must be designed by a Qualified Person, and must be installed and used under the supervision of a competent person.
- Do not using combinations of components or sub-systems, or both, which may affect or interfere with the safe function of each other.
- Only use components rated for the same weight capacity or Higher. Not all fall protection components are rated for the same user weight capacity.
- Evaluate space below work area to ensure potential fall path is clear of obstructions. Allow adequate fall clearance below the work surface.
- Do not use or install equipment without proper training from a "Competent Person".
- Store this equipment in a cool, dry, and clean environment that is out of direct sunlight when not in use.

2. Connection Compatibility Limitations

All equipment must be coupled only to compatible connectors that are suitable to your application. Ensure all connections are compatible in size, shape and strength. Ensure all connectors are fully closed and locked. Prohibit the use of snap hooks to engage to objects unless the following requirements are met:

- It must be a locking type snap hook.
- It must be explicitly designed for such a connection. “Designed for” means that the manufacturer of the snap hook specifically created the snap hook to be used to connect to the equipment in question.

Use of a non-locking snap hook can result in rollout*. Snap hooks and carabiners are designed to be used only as specified in each product’s user instructions. See as following shown for inappropriate connections.



Avoid the following type of connections:

- Connection of two (or more) snap hooks/rebar hooks or carabiners to one D-ring.
- Connection of a snap hook/rebar hook back to its integral lanyard.
- Direct connection of a snap hook/rebar hook to horizontal lifeline.
- Connection in a manner that results in a load on the gate.
- False engagement connections, where protruding features of the snap hook/rebar hook or carabiner may catch on the anchor and seem to be fully engaged to the anchor point. Always confirm engagement.
- Connection to snap hooks or carabiners.
- Do not connect a snap hook/rebar hook into a loop or thimble of a wire rope or attach in any way to a slack wire rope.
- Direct connection to webbing lanyard, webbing loop, rope lanyard or tie-back. (Unless the manufacturer’s instructions for both the lanyard and connector specifically allow such a connection.)
- Connection of a snap hook to a D-ring, rebar or other connection point of improper dimensions in relation to the snap hook dimensions or configurations that could cause the snap hook keeper to be depressed by a turning motion of the snap hook, or such that snap hook or carabiner will not fully close and lock, or that roll-out could occur.
- Snap hook/rebar hook must be free to align with applied load as intended.
- Carabiner may be connected to a loop or ring connector already occupied by a choker style connector. This type of connection is prohibited for snap hooks/rebar hooks.

* Rollout: A process by which a snap hook or carabiner unintentionally disengages from another connector or object to which it is coupled.

3. Performance

The performance of equipment in accordance with the requirements of the ANSI Z359.18-2017.

Model/Reference	Features	Min. Breaking Strength	Material of Construction	Standard Regulation
RO01	Reusable	5000 lbs / 22.2 kN	Plate Steel	ANSI Z359.18-2017

When installed as an anchor point on a flat surface or on one side of a peaked roof, the connecting fall arrest subsystem must not extend over the peak of the roof to the other side.

When working on the opposing roof surface, installation of an additional Reusable Roof Anchor is required on that side. Anchor must be positioned to apply load in the long axis of the anchor bracket.

After removal of the Reusable Roof Anchor, roof surface may require repairs. It is the responsibility of the installer to make applicable repairs to the roof materials.

Reusable Roof Anchor can be used on a maximum roof slope of 12/12 pitch.

Attachment:

Center on the ridge of roof framing assembly. Position the anchor on the roof such that the holes along the center of the legs are centered directly over the center of the roof framing member. The roof anchor must be positioned over top of previously secured roof sheathing (do not attach directly to rafter or truss).

Nails:

The 6 center holes and 1 row of the outer holes on each leg must be used. The 6 center holes must be centered on the framing section and the 5 outer holes must penetrate through substrate. At least 22 nails must be used as shown below. It was fixed using twisted nails measuring 3.6 inches length & 0.15 inches diameter.

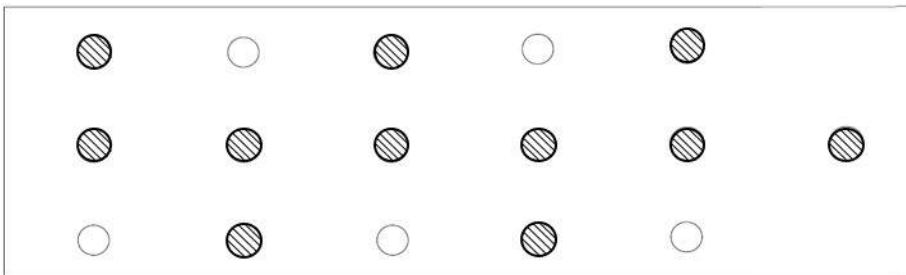

4. Loading Direction Limitation

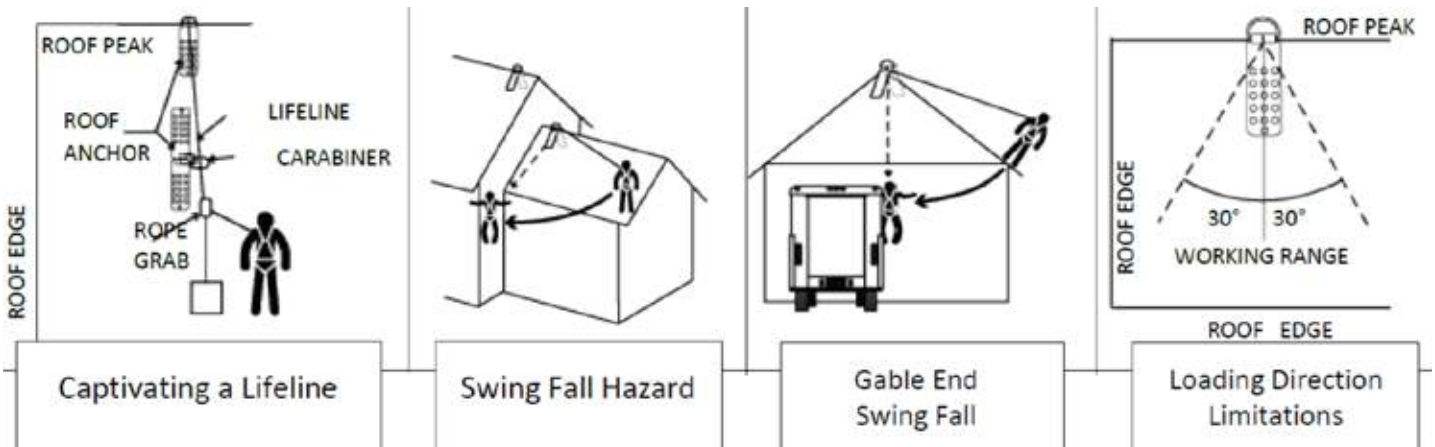

5. Installation

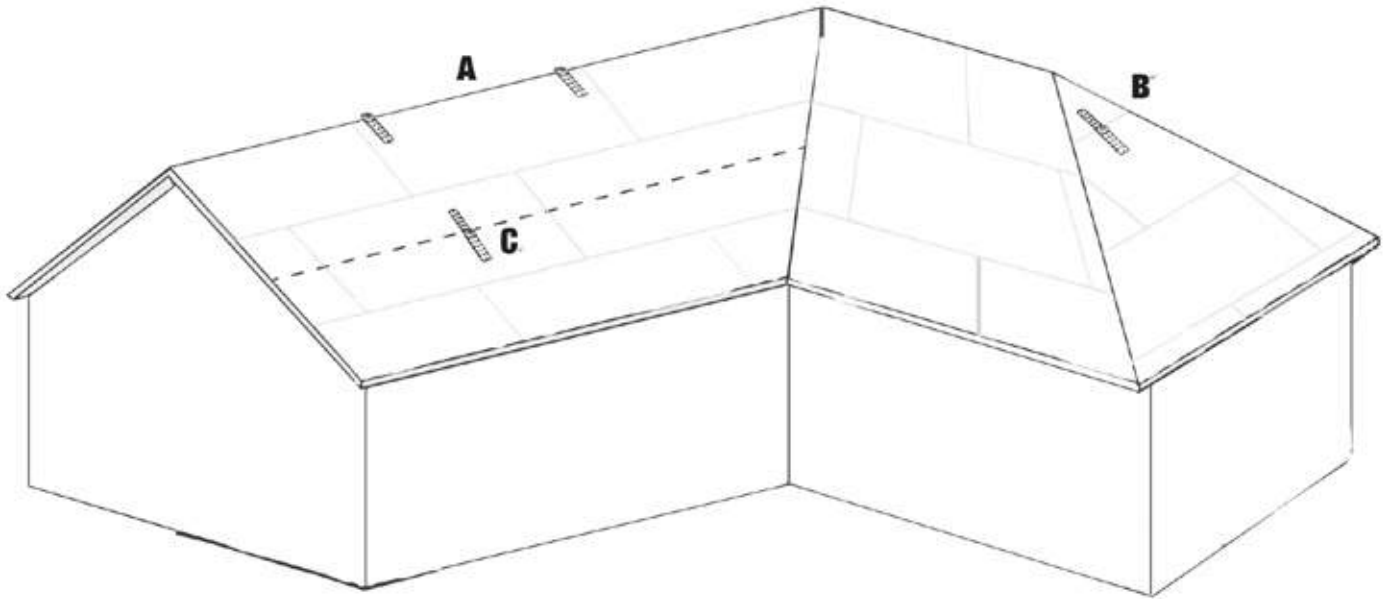

A	Roof Ridge	No more than 8' of spacing between roof anchors installed on Roof Ridges
B	Hip Face	At least one roof anchor on each Hip Face
C	Roof Edge	No less than 6' from an exposed Roof Edge

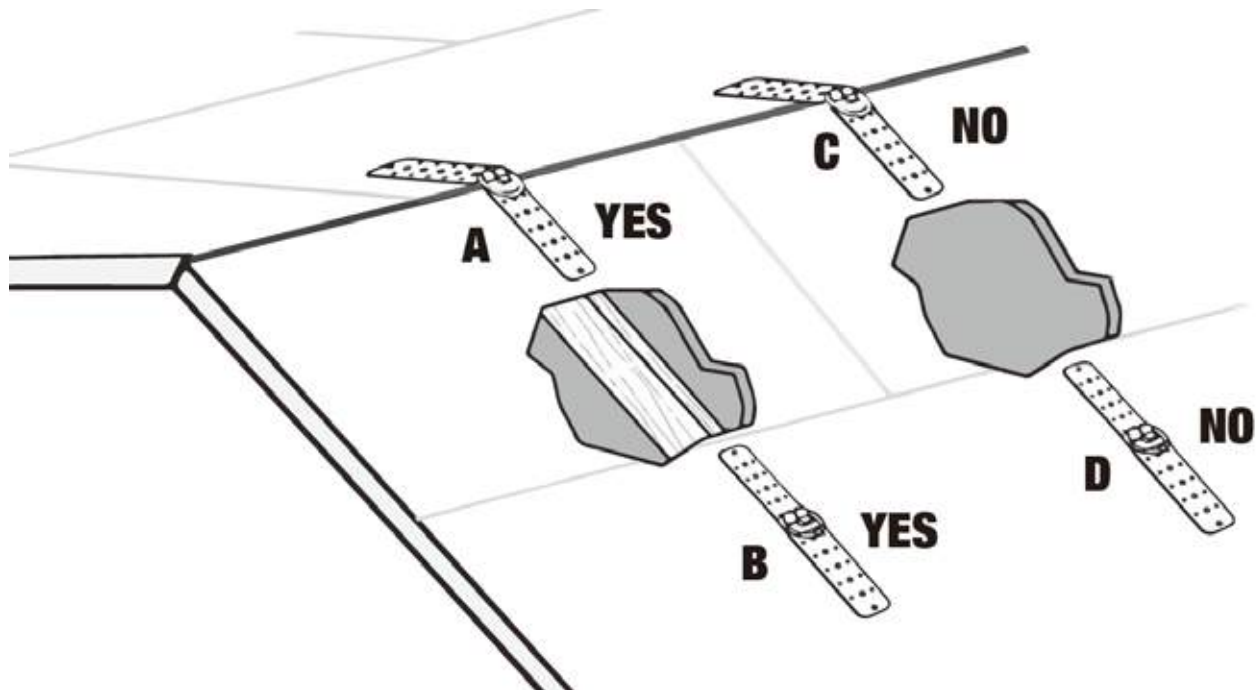

When multiple roof anchors are installed, the strength (static load) above must be met at each roof anchor's installation point independently.

Anchorage used for attachment of a personal fall arrest system shall be independent of any anchorage being used to support or suspend platforms, and must support at least 5,000 lbs (22.2 kN) per user attached; or be designed, installed, and used as part of a complete personal fall arrest system which maintains a safety factor of at least two, and is supervised by a qualified person.

6. Training

Employers are responsible for providing training to any employee who may be exposed to fall hazards in order to enable the employee to recognize and reduce fall hazards. Training must be conducted by a Competent or Qualified Person. Trainer and trainees must not be exposed to fall hazards during the training course.

7. Inspection

If inspection reveals any defect, inadequate maintenance, or unsafe condition, remove Reusable Roof Anchor from service immediately.

Any Roof Anchor that has been subjected to the forces of arresting a fall must be removed from service immediately.

The inspection should be carried out according to the following steps:

Step 1: Inspect Roof Anchor for physical damage, e.g. any signs of cracks, dents, or deformity. Check for bending or bowing of roof anchor legs.

Step 2: Inspect Roof Anchor for signs of corrosion.

Step 3: Ensure the condition of the roof anchor is capable of supporting Roof Anchor load. Do not connect any Roof Anchor to rotten or degraded wood; do not use any Roof Anchor connected to rotten or degraded wood.

Step 4: Ensure Roof Anchor remains securely attached. If Roof Anchor is loose, do not use.

Step 5: Inspect each system component or subsystem per associated manufacturer's instructions.

Step 6: Record the inspection date and results in your inspection log.

If inspection reveals any defective condition, remove from service immediately.

Frequency

All equipment must be visually inspected prior to each use according to the manufacturer's instructions included at time of shipment. Inspections must be performed by a Competent Person other than the user a minimum of every 6 months. Record the results of each formal inspection in your inspection log.

NOTE: Per PFAS must be inspected by a competent person at least six months, in accordance with the manufacturer's recommendations, with inspection dates documented.

8. Cleaning, Maintenance and Storage

Cleaning

The equipment surface should be wiped down with a clean, dry cloth to remove grease or dirt during the use.

Maintenance

Maintenance/Repair of the equipment can be made only by representative or person or entity authorized by **Frontline**. Any equipment requiring maintenance must be tagged "unusable" or removed from service.

Storage

- When not in use, equipment should be stored in a cool, dry place out of direct sunlight.
- Do not store in areas where damage from environmental factors such as heat, light, excessive moisture, oil, chemicals and their vapors, or other degrading elements may be present.
- Do not store damaged equipment or equipment in need of maintenance in the same area as product approved for use. Equipment must be cleaned and dried prior to storage.
- Equipment that has been stored for an extended period must be inspected as described in this *User Instructions* prior to use.

9. Labeling

All labeling must be legible and attached to the equipment.

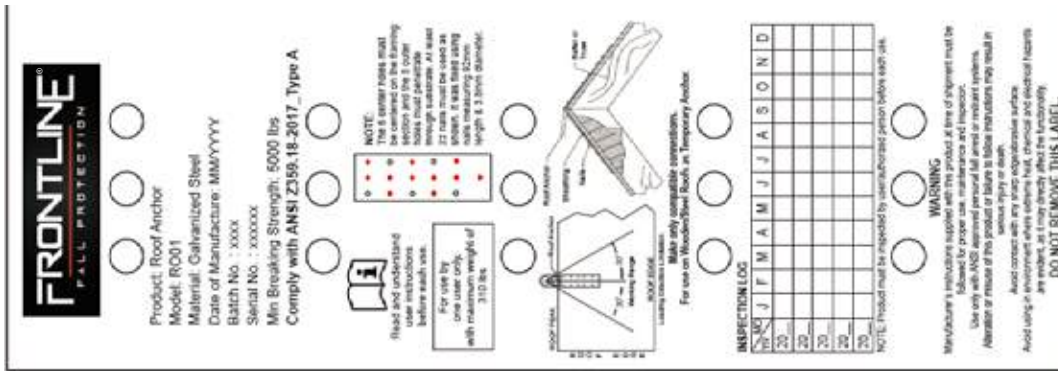

10. Checking Card

If equipment fails inspection **IMMEDIATELY REMOVE FROM SERVICE.**

User must inspect prior to **EACH** use.

Competent Person must do complete formal inspection at least 1 time per 6 month period.

All inspection records must be made visible and available to all users at all times.

Checking Card				
Product code				
Serial number				
Date of manufacture				
Date of first use				
Inspection Log				
Date	Reason for entry (periodic examination or repair)	Competent person name + signature	Comments	Next Due date for periodic examination
Manufacture: Frontline Fall Protection Inc. 2111 NW 84th Ave, Miami, Florida 33122, U.S.A. Website: www.frontlinefall.com Email: info@frontlinefall.com				