

SPEC SHEET

Frontline STW01 Weld-on Anchor



STW01

Features

Performed by AWS certified welders to ensure quality welding and upmost compliance

Anchor is made of ASTM rated steel for reassured product reliability and quality

Can be installed in most structural steel substrates

Ready to use straight out of the bag

Design Specifications

Total weight	1 lb
Base thickness	3/8"
Tensile Strength	5,000-lbf/22kN
User Maximum Capacity	310 lbs

Relevant Standards

ANSI	Z359.1-2007
	A10.32 2012
OSHA	CFR 1926.502
	CFR 1910

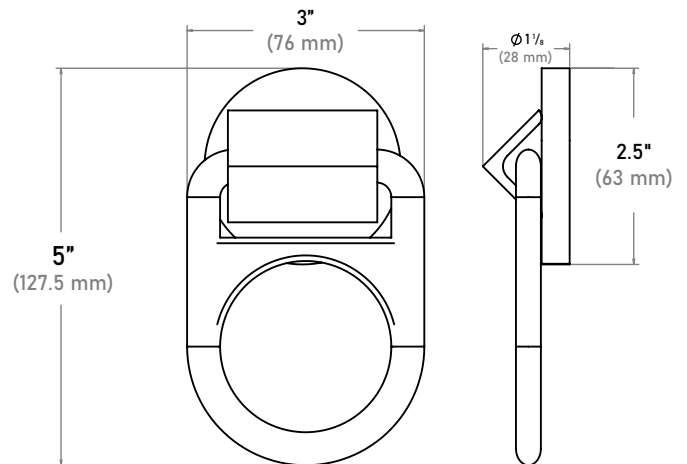

www.frontlinefall.com info@frontlinefall.com

6 Lee Blvd, Malvern, PA 19355