



MALTA DYNAMICS

Truss Anchor

Instruction Manual - A8000

Truss Anchor INSTRUCTION MANUAL

These instructions apply to the following model(s):
A8000 - Truss Anchor

Manual Revision:
MD-CASUIM181112

A copy of this manual must be available to users at all times. Visit www.MaltaDynamics.com for the latest user instruction manual based upon date of manufacture.



TABLE OF CONTENTS

Under Penalty of Law -----	4
Materials and Construction -----	4
Purpose -----	4
Instructions for Use -----	5
Limitations for Use -----	6
Connector Compatibility Limitations -----	8
Connecting Component Limitations -----	9
Performance -----	11
Training -----	14
Inspection -----	14
Maintenance and Cleaning -----	15
Product Labels -----	16-18
Inspection Log -----	19
Warranty -----	20



UNDER PENALTY OF LAW

This manual must be read and understood in its entirety, and used as part of a fall protection training program, as required by OSHA or any state/local regulatory agencies. This instruction manual is intended to meet industry standards required by ANSI Z359.18-2017 and should be used as part of an Employee Fall Safety Training Program as required by OSHA. User must read and fully understand the limitations and proper use of equipment. All users must be properly trained by their employer prior to use, per OSHA 29 CFR 1910.66, 29 CFR 1926.503, and applicable local standards.

NOTE: This *User Instruction Manual* is not to be removed except by the equipment user. Current *User Instruction Manuals* must always be available to the user. Read and understand these instructions before using equipment. *Do not discard these instructions.*

WARNING

Misuse or failure to follow warnings, instructions, and limitations on the use of this equipment may result in serious personal injury or death. For further instructions about proper use, refer to a supervisor or contact Malta Dynamics at 1-800-494-1840.

MATERIALS AND CONSTRUCTION

- **Hardware:** Plated alloy steel, 5000 lbs. minimum breaking strength

PURPOSE

Malta Dynamics Truss Anchors are intended for use as part of a comprehensive personal fall arrest (PFAS) or personal fall restrain (PFR) system. Concrete Anchor Straps are designed for single use only and as a temporary anchorage connector for a PFAS or PFR system. Re-use may result in serious injury or death.

The Truss Anchor must never be used to lift, hang, or support equipment. When used as part of a comprehensive PFAS, workers must also use a full body harness and shock absorbing lanyard/self-retracting lifeline that limits free fall to a maximum of six feet. When used as part of a comprehensive PFRS, workers must use a full body harness OR a work positioning belt and lanyard.

INSTRUCTIONS FOR USE

WARNING

Do not alter or intentionally misuse this equipment.

1. A user must be of sound mind and body to properly and safely use this equipment in normal and emergency situations. Users must have a physician ensure they are clear of any medical conditions that may affect the proper and safe use of this equipment in normal and emergency situations.
 2. Before using a personal fall arrest system, user must be trained in the safe use of the system and its components.**
 3. Use only the ANSI/OSHA compliant personal fall arrest or restraint systems. The anchorage must have the strength capable of supporting a static load, applied in the directions permitted by the system, of at least 5,000-lbf (22kN) in the absence of certification.
 4. The user shall be equipped with a means of limiting the maximum dynamic forces exerted on the user during the arrest of a fall to a maximum of 900-lbf (4kN).
 5. Use of this product must be approved by an engineer or other qualified person* to be compatible* with any and all structural & operational characteristics of the selected installation location and system to be connected to this anchorage connector.
 6. The anchorage connector must be inspected prior to each use for wear, damage, and other deterioration. If defective components are found, the anchorage connector must be immediately removed from service in accordance with the requirements in accordance with the INSPECTION AND MAINTENANCE LOG.**
 7. The anchorage connector should be positioned in such a way that minimizes the potential for falls and the potential fall distance during use. The complete fall protection system must be planned (including all components, calculating fall clearance, and swing fall) before using.
 8. A rescue plan, and the means at hand to implement it, must be in place that provides the prompt rescue of users in the event of a fall, or assures that users are able to rescue themselves.
 9. After a fall occurs, the anchorage connector must be removed from service and destroyed immediately.
- Store this equipment in a cool, dry, and clean environment that is out of direct light when not in use to prevent UV degradation.
 - Do not expose this equipment to chemicals or harsh solutions that may have a harmful effect.
 - Thoroughly evaluate and plan all elements of fall protection system(s) before using this equipment. Make sure that your Personal Fall Arrest System is appropriate for your needs and facility. Calculate fall clearance and swing fall clearance. The amount of clearance required is dependent on the type of connecting subsystem (rope grab, lanyard), the anchorage location, and the amount of stretch in the lifeline. When calculating distance, be sure to consider:
 - Deceleration Distance
 - Movement of harness attachment element (D-Ring)
 - Free Fall Distance
 - Height of the Worker (how tall is the worker?)
 - Elevation of Anchorage Connector
 - Connecting Subsystems Length



- **Swing Falls** occur when the anchorage point is not directly above the point of a fall. The force of striking an object in a swing may cause serious injury or death. Minimize potential for swing falls by working as close to the anchorage point as possible. Do not permit a swing fall if injury could occur. Swing falls significantly increase the amount of clearance required. **See Illustration 1.**

Illustration 1: Examples of Swing Fall Hazards

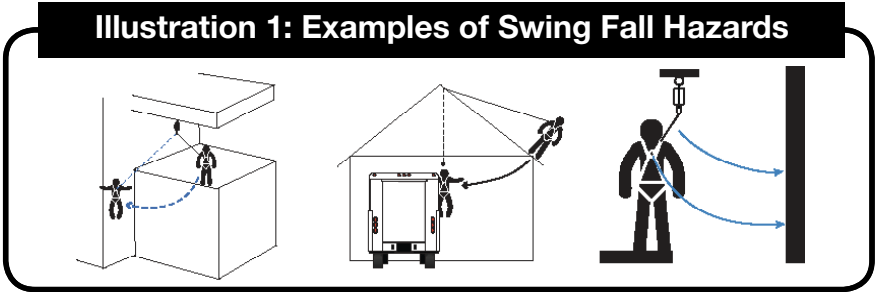

LIMITATIONS FOR USE

! WARNING

Do not use this equipment if you are unable to tolerate the impact of a fall arrest. Age and fitness can seriously affect your ability to withstand a fall. Consult with a physician if in doubt. Minors, pregnant women, and anyone with a history of back and/or neck problems must not use this equipment.

! WARNING

Use caution when employing this equipment around machines, electrical hazards, chemical hazards and sharp edges or abrasive surfaces, as contact may cause equipment failure, personal injury, or death.

! WARNING

Altering or misuse of this product could lead to injury or death.

- Use only with compatible components of subsystems. Substitutions or replacements made with non-approved components may jeopardize equipment compatibility and affect system safety and reliability.
- This equipment is designed for a single user. Combined user weight, including

clothing and tools must not exceed weight capacity.

- This equipment is designed to be used in temperatures ranging from -30°F to +130°F (-40°C - +54°C).

Anchorage Strength:

In accordance with ANSI Z359.18-2017, anchorage selected for **Personal Fall Arrest Systems must meet all** anchorage strength requirements.

- **Personal Fall Arrest:** Anchorages used for PFAS must be capable of sustaining static loads in the direction permitted by the PFAS of at least: 3,600 lbs. with certification of a qualified person; or 5,000 lbs. without certification. When more than one PFAS is attached to an anchorage, the strengths stated above must be met independently at and for each anchorage location.
- **Work Positioning:** The structure to which the work positioning system is attached must sustain static loads applied in the directions permitted by the work positioning system of at least 3,000 lbs., or twice the potential impact load, whichever is greater. See OSHA 1926.502. When more than one work positioning system is attached to an anchorage, the strengths stated above must be multiplied by the number of work positioning systems attached to the anchorage.
- **Restraint:** Anchorages selected for rescue systems must be capable of sustaining static loads of at least: 1,100 lbs. When more than one restraint and travel restraint system is attached to an anchorage, the strengths stated above must be multiplied by the number of work positioning systems attached to the anchorage.
- **Rescue:** The structure to which rescue system is attached must sustain static loads applied in the directions permitted by the work positioning system of at least 3,000 lbs., or five times the potential impact load, whichever is greater. See OSHA1926.502. When more than one work positioning system is attached to an anchorage, the strengths stated above must be multiplied by the number of work positioning systems attached to the anchorage.

Fall Arrest	Non-Certified Anchorage	5,000 lbs. (22.2kN)	Multiple Systems: When more than one of the defined systems is attached to an anchorage, the strength defined shall be multiplied by the number of systems attached to the anchorage.
	Certified Anchorage	3,600 lbs. (16.1kN)	
Restraint	Non-Certified Anchorage	1,100 lbs. (22.2kN)	
	Certified Anchorage	≥ 2 Times the Maximum Potential Impact Load	

Work Positioning	Non-Certified Anchorage	3,000 lbs. (22.2kN)	Certified Anchorage: An anchorage for Personal Fall Arrest, Work Positioning, Restraint or Rescue systems that a qualified person certified to be capable of supporting the potential fall or that meets the criteria for a certified anchorage point, as prescribed by relevant ANSI and OSHA standards.
	Certified Anchorage	≥ 2 Times the Maximum Potential Impact Load	
Rescue	Non-Certified Anchorage	3,000 lbs. (22.2kN)	
	Certified Anchorage	≥ 5 Times the Maximum Potential Impact Load	

CONNECTOR COMPATIBILITY LIMITATIONS

Malta Dynamics equipment must be coupled only to compatible connectors that are suitable to your application. Ensure all connections are compatible in size, shape and strength. Ensure all connectors are fully closed and locked. OSHA 29 CFR 1926.502 prohibits the use of snap hooks to engage to objects unless the following requirements are met:

- Snap hook must be an ANSI-style locking model.
- Snap hook must be explicitly designed for such a connection, meaning that the manufacturer of the snap hook specifically it to connect to the equipment in question.

Use of a non-locking snap hook can result in rollout (a process by which a snap hook or carabiner unintentionally disengages from another connector or the object to which it is coupled (ANSI Z359.0- 2012). Malta Dynamics connectors (snap hooks and carabiners) are designed to be used only as specified in each product’s user’s instructions.

Avoid the following types of connections:

- Two or more snap hooks or carabiners attached to one D-Ring.
- A snap hook connected to its integral lanyard.
- A snap hook connected to a horizontal lifeline.
- Connection in a manner that results in a load on the gate. NOTE: *Large throat opening snap hooks should not be connected to standard size D-Rings or similar objects. This could result in a load on the gate if the hook or D-Ring twists or rotates. Large throat snap hooks are designed for use on structural elements such as rebar or cross members that are not shaped to capture the gate of the hook.*
- False engagement connections, where protruding features of the snap hook or carabiner may catch on the anchor and seem fully engaged to the anchor point. Always confirm engagement.
- Connection to snap hooks or carabiners.
- Direct connection to webbing lanyard, webbing loop, rope lanyard or tie-back

(unless the manufacturer's instructions for both the lanyard and connector specifically allow such a connection).

- A snap hook connected to a D-Ring, Rebar, or other connection point with improper dimensions/configurations could cause the snap hook keeper to become depressed by the turning motion of the snap hook; the snap hook or carabiner may not fully close and lock or roll-out may occur.

Illustration 2 depicts examples of inappropriate connections:

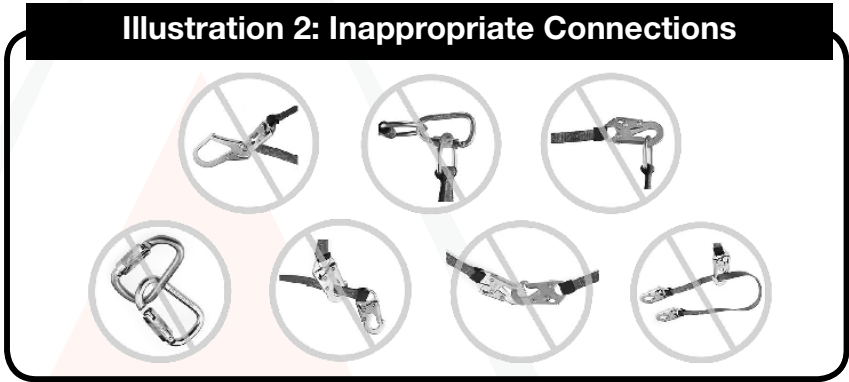

CONNECTING COMPONENT LIMITATIONS

- The Malta Dynamics Truss Anchor is designed for a single user only. To maintain ANSI compliance, the ANSI working capacity range is 130 lbs. to maximum 310 lbs. including clothing, tools, etc.
- Do not use if any part of the device appears to be damaged.
- Do not attempt to service the device or alter it in any way.
- The following application limitations must be recognized and considered before using this product:
- **Capacity:** This equipment is for use by one person with a combined weight (person, clothing, tools, etc.) of 130 lbs. to 310 lbs. if used in combination with equipment explicitly certified for such use.
- **Free Fall:** Lanyards used for work positioning applications must be rigged to minimize any potential vertical free fall. In no case should potential free fall be greater than two feet. For situations where free fall may exceed two feet, a backup fall arrest system should be used. If D-Ring extension assemblies are used in conjunction with a self-retracting lifeline or an energy absorbing lanyard in a fall arrest application, the length of the D-Ring extension assembly must be taken into account when calculating free fall distance and fall clearance requirements.
- **Fall Clearance:** Always ensure fall clearance distance before using lanyards equipped with energy absorbers (shock packs). If there is a risk of fall or if the

only anchorage is below the attachments points on a harness, it is essential to use a lanyard provided with an energy absorber. Before using an energy absorbing lanyard, check that there is sufficient fall clearance below the user to prevent any collision with structure or ground. **See Illustration 4.**

- **Backup Fall Arrest System:** Some applications of this equipment may require the use of a backup fall arrest system such as when using a Y-lanyard to suspend a person in an Easy Seat.

System:

- A Competent Person must ensure the compatibility of all connections and that of the system.
- Do not use the system if any component in the system does not operate properly.
- Do not use if any part of the system appears to be damaged.
- Do not use a body belt for fall arrest applications.
- Do not use this system if it has been used to arrest a fall. If it has been used to arrest a fall, it must be removed from service immediately.

BEFORE EACH USE

- Inspect the Truss Anchor for any damage or soiling (dirt, oil, paint, etc.)
- Ensure self-locking snap hooks & carabiners work properly. Inspect rope or webbing for wear, cuts, burns, frayed edges, or other damage.
- **Anchorage:** Select a rigid anchorage point capable of supporting required loads. Select appropriate anchorage point that will reduce possible free fall and swing fall hazards and avoid striking an object during a fall. Anchorage should be level (horizontal) in order to prevent the connector from sliding on an incline when in use, which could cause serious injury to the user.
- **Fall Clearance:** Should a fall occur, there must be sufficient clearance in the fall area to arrest the fall before striking the ground or other object.
- **Free Fall:** Personal fall arrest systems must be rigged in such a way that the free fall does not exceed 6 ft. Avoid working above the anchorage level to avoid an increase in fall distance.
- **Fall Arrest Forces:** The assembled Personal Fall Arrest system must limit maximum arrest forces to 1800 pounds (8 kN) or less. Deceleration distance shall not be allowed to exceed 48 in.
- Energy absorber portion of the lanyard must be connected to the Dorsal D-Ring only.
- Do not attach the energy absorber to the anchorage.
- Do not attach the free (unused) leg of the lanyard back to the harness at any location unless a specifically designed lanyard keeper is provided for this purpose.
- Connection of both lanyard legs to separate anchorage points is acceptable.
- Never connect more than one person to a Y-type lanyard.
- Do not allow any lanyard to pass under arms and legs during use.
- To connect to the Truss Anchor, use a self-locking snap hook or double-locking carabiner only.
- For proper compatibility of the anchorage and snap hook, the D-Ring O-Ring, or connection component of the anchorage connector should have an inside diameter of at least 2-1/2 times of gate opening on the snap hook.
- Ensure connections are fully closed.
- If using a shock absorbing lanyard, connect the shock absorbing component to the full body harness.
- If using a self-retracting lifeline, connect double-locking snap hook or carabiner to the full body harness.
- Make sure cable/web flow is not hindered and NEVER connect more than one PFAS or PRS to a single anchor.



Connecting to a Self-Retracting Lifeline: Connecting an energy absorbing lanyard or component to a self-retracting lifeline is not recommended. Special applications exist where it may be permissible. Contact Malta Dynamics if considering connecting an energy absorbing lanyard to a self-retracting lifeline.

Knots: Knots of any kind are not approved in lanyards. Strength is drastically reduced by tie-offs using knots, tying around sharp edges, etc. Tie-offs using a knot in a rope lanyard (at any location) reduces the lanyard strength by 50 percent or more. Tie-off around an “H” or “I” beam can reduce the strength of lanyard by approximately 70 percent due to cutting action of beam edges.

Anchorage: Select a rigid anchorage point that is capable of sustaining the loads specified in LIMITATIONS FOR USE Section of this manual. For fall arrest applications, select anchorage locations that will minimize free fall and swing fall hazards. For restraint applications, locate the anchorages such that no vertical free fall is possible.

Free Fall: Maximum free fall distance allowed for use in a Personal Fall Arrest System is 6 ft. For use in a Restraint System, no vertical free fall is permitted. Do not work above the anchorage level to avoid increased free fall distance.

Fall Arrest Forces: The assembled Personal Fall Arrest system must limit maximum arrest forces to 1800 pounds (8 kN) or less. Deceleration distance shall not be allowed to exceed 48 in.

Swing Falls: Minimize swing falls by working as directly below the anchorage point as possible. Do not permit a swing fall if injury could occur.

Fall Clearance: Clearance required is dependent upon the subsystem and lanyard properties. Energy absorbers can extend the fall arrest distance by up to 48 inches. Other factors may influence the required clearance distances. Use caution when assembling system components that could extend the fall arrest distance (and therefore fall clearance required). Consider the following when calculating fall clearance:

Clearance Required is Dependent On the Following Factors:

- Elevation of Anchorage
- Connecting Subsystem Length
- Deceleration Distance
- Free-Fall Distance
-

Illustration 4: Fall Clearance Considerations

- A. Connecting Subsystems (Energy Absorbing Lanyard shown) Length + Movement of Harness Attachment + Length of FBH Stretch + Settling of User's Body While in the Harness
- B. Working Level (Thickness)
- C. Worker Height + Connector Length
- D. Free-Fall—6' Max. (per ANSI Z359.1)
- E. Deceleration Distance
- F. Total Fall Distance: Sum of A through E
- G. Lower Level or Obstruction

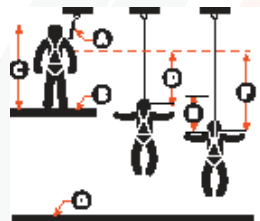

If there is a risk of fall or if the only anchorage point is below the attachment points on the harness, it is essential to use a lanyard provided with an energy absorber. Before using a shock absorbing lanyard, ensure that there is sufficient fall clearance below the user to prevent any collision with the structure or the ground.

Calculating Total Fall Distances:

Total Fall Clearance below worker is calculated from Anchorage Connection.

is clear of obstructions and equipment. Avoid potential contact with a lower level.

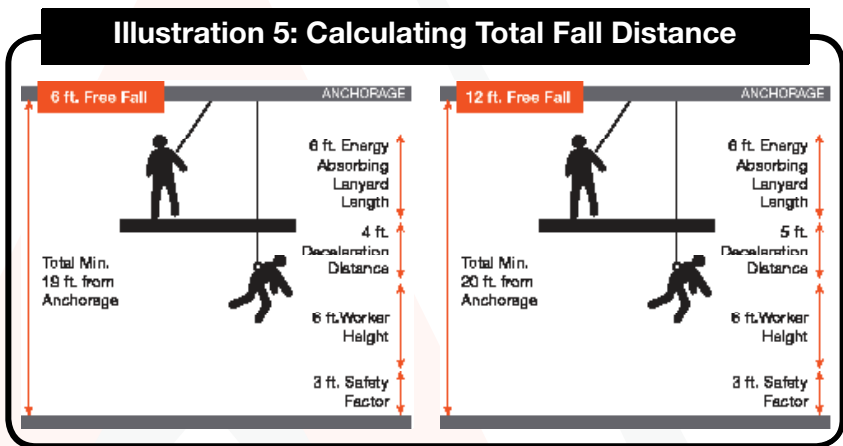

Sharp Edges: Avoid working where your lanyard or other system components will be in contact with, or abrade against, unprotected sharp edges.

Rescue: The employer must have a written rescue plan and the ability to implement it.

After a Fall is Incurred: Components subjected to fall arrest forces must be removed from service immediately.

Making Connections: Ensure roll-out cannot occur when using a snap hook to connect components to an anchorage. Use self-locking snap hooks and carabiners to reduce the possibility of roll-out.

- Do not attach a snap hook directly to a horizontal lifeline.
- Follow manufacturer's instructions for each component of the system.



TRAINING

Employers must provide training to any employee who may be exposed to fall hazards in order to enable the employee to recognize and reduce fall hazards. Training must be conducted by a Competent or Qualified Person. Trainer and trainees must not be exposed to fall hazards during the training course. This equipment is intended to be used by persons trained in its correct application and use.

INSPECTION

Note: Keep all instructions available for reference. Record the date of first use:

Record all observations and results of each inspection in your Hog Tracker account or inspection log. If inspection reveals any defect, inadequate maintenance, or unsafe condition, remove Truss Anchor from service immediately. Any equipment that has been subjected to the forces of arresting a fall must be removed immediately.

Note: Equipment must not be altered in any way, including attempted repair. Only manufacturer, or entities authorized in writing by the manufacturer, may make repairs to this product.

- Equipment must be free of corrosion, chemical degradation, excessive heat, or extreme wear.
- All markings must be legible and attached to the equipment.
- Inspect hardware (snap hooks, adjusters, thimbles, spreader bar, etc.) for evidence of distortion, sharp edges, burrs, cracks, worn parts, or corrosion.
- Make sure connecting snap hooks work correctly, move freely and lock upon closing.
- Snap hook gate spring provides tension to keep the snap hook gate closed in a locked position; snap hook must close flat and exhibit no sideways play. Ensure adjusters, if present, work properly.
- All webbing must be free of frayed or broken fiber, pulled stitches, tears, abrasions, mold, burns or discoloration.
- Inspect webbing and stitching by pressing to bend webbing over a 1½ inch diameter object. Webbing and stitching must be free of cuts, fraying or signs of wear.
- Shock absorbing devices must show no evidence of elongation or activation.
- Ensure energy absorber cover is not torn or damaged, and is securely in place.



WARNING

Harsh weather and harsh environments, prolonged use, and other extreme working conditions may require you to have this inspected by a competent or qualified person than yourself at least **once** a year.

If inspection reveals any defective condition, remove from service immediately.

MAINTENANCE & CLEANING

Wipe off all surface dirt. Wash anchor strap with a solution of water and mild detergent to clean away contaminants; wipe hardware dry with a clean cloth. Hang away from heat and allow to dry completely. Store in dry, clean environment away from direct sunlight and excessive heat. Avoid storage in areas where chemical vapors may exist. Thoroughly inspect lanyard after extended storage.

Frequency:

- All equipment must be visually inspected prior to each use according to the manufacturer's instructions included at time of shipment. Inspections must be performed by a Competent Person other than the user (as defined by OSHA) a minimum of **once** per year.
- Record the results of each formal inspection in your Hog Tracker account or inspection log.
- NOTE: Per Cal/OSHA PFAS must be inspected by a competent person at least **once** a year, in accordance with the manufacturer's recommendations, with inspection dates documented.

Repairs to the Concrete Anchor Strap can only be made by a Malta Dynamics Fall Protection representative or an entity authorized by Malta Dynamics. Contact us for all maintenance and repair needs or to inquire about a return at: 1-800-494-1840.

PRODUCT LABELS

The following labels are affixed to the product and must not be removed:



LABEL LOCATIONS

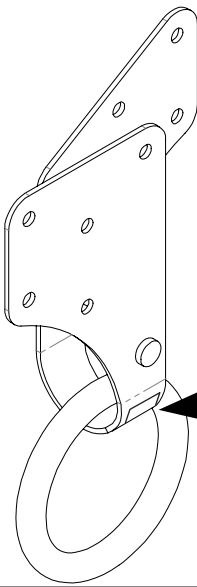

Model: 48000
 Truss Anchor
 270 122a Street, Malta, OH 43028
 800-494-1840 | MaltaDynamics.com

Users: (1) Factory Use.
 Type: T
 Min. Break Strength (MBS): 5000 lbs
 Service Temperature: 30°F - 120°F
 Max Capacity:
 310 lbs Capacity Range 300, 310 lbs
 Material: Steel (INSPECT BEFORE USE)
 MFD Date:
 Batch #:

Compliance: ANSI Z359.18-2017 & OSHA 1926.502
WARNING: Do not use if equipment is damaged, broken, corroded, or cracked.
 Do not use on prohibited work surfaces. (APPLICABLE) Connections per anchor.
 For all uses, fully read and understand manufacturer's instructions attached with
 this anchor. In the event of a defect or failure to do so could result in serious
 injury or death. ALWAYS INSPECT EQUIPMENT PRIOR TO EACH USE. A
 competent person shall be authorized to full status and working order
 of equipment. Inspected annually. **MADE IN USA**

TERMS AND DIMENSIONS

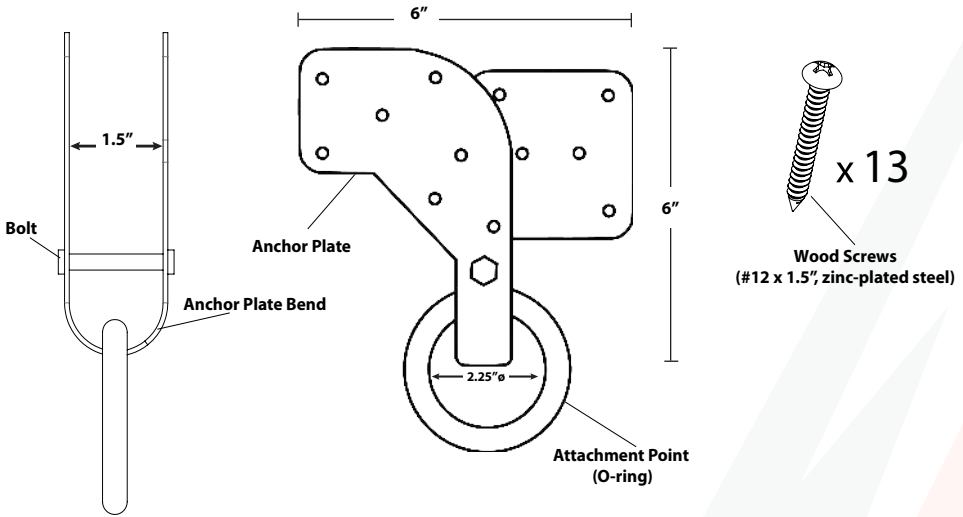

Minimum Breaking Strength (MBS): 5,000 lbs
Max Capacity: One person, 310-lbs
Materials: Zinc-Plated Steel
Regulatory Compliance: ANSI Z359.18-2017 & OSHA 1926.502

LOADING CONDITIONS DIAGRAM

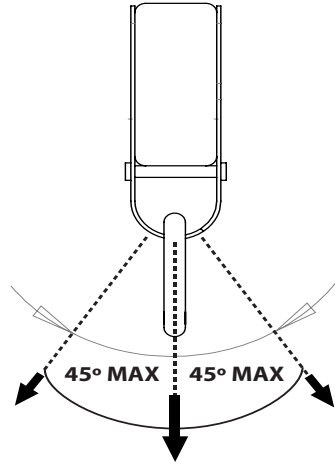
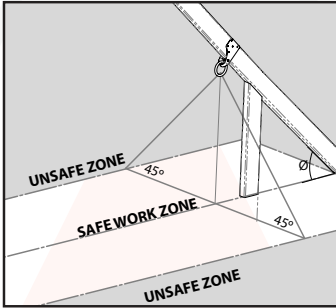
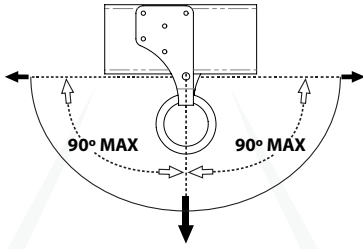

ANCHORAGE REQUIREMENTS

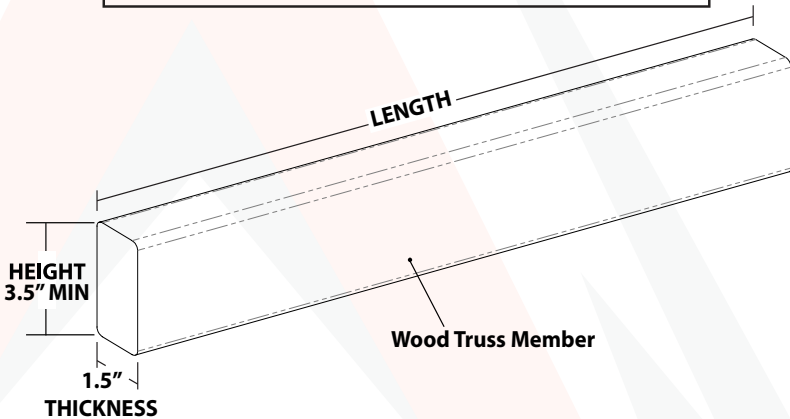

- Only install in Wood Truss Members with a nominal thickness of 2" (1.5" actual) and a nominal height of 4" (3.5" actual) or greater.
- Anchorage must be capable of supporting 3,600-lbf (16kN), or be designed, installed, used under supervision of a qualified person, and as part of a complete personal fall protection system that maintains a safety factor of at least two.
- Wood Truss Member and all other structural members supporting it must be free of voids, rot, decay, and any other factors that may reduce anchorage strength below previous requirements. Additional factors that may significantly affect the lumber strength include but are not limited to: species, grade, knots, splits, cracks, certain grain qualities, moisture content, and temperature.
- **A Qualified person must determine if a specific installation location will meet all ANCHORAGE REQUIREMENTS.**



INSTALLATION INSTRUCTIONS

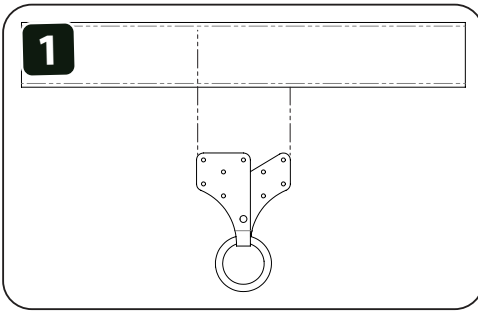

1. Choose location in Wood Truss Member. A qualified person must determine if a specific installation location will meet all ANCHORAGE REQUIREMENTS.

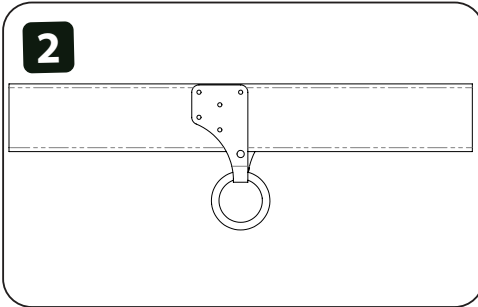

2. Place Anchorage Connector on Wood Truss Member and align. Bolt should be flush with Wood Truss Member. Alignment edge should be perpendicular to length of Wood Truss Member.

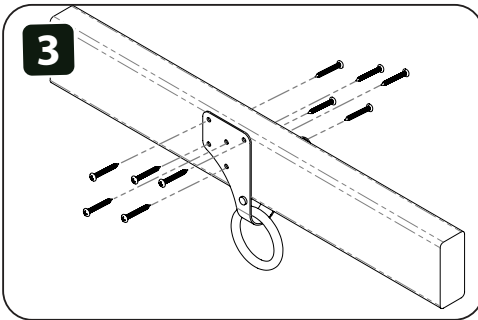

3. Fasten with all 13 wood screws (included). Note: To decrease the chance of splitting, Pilot holes ($7/64'' \text{ } \varnothing$ for soft woods or $1/8'' \text{ } \varnothing$ in hard woods) are recommended. If splitting occurs the anchorage connector **must be** moved to a new approved location.

WARNING: Do not overtighten screws. Proper installation requires all 13 wood screws to be fastened without stripping.

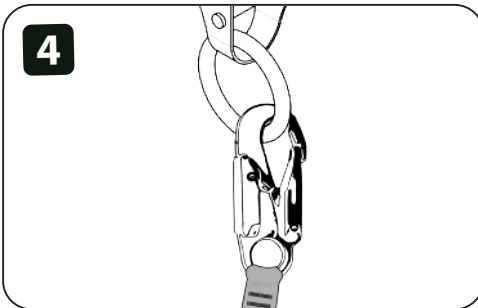

4. Connect personal arrest system (PFAS) to attachment point. PFAS must limit fall arrest forces to 900-lbf (4kN) or less.

WARNING: Make only compatible connections. Only connect to the specified attachment point (O-ring). Direct connection in any other location is prohibited.

WARRANTY

THE FOLLOWING IS MADE IN LIEU OF ALL WARRANTIES OR CONDITIONS, EXPRESS OR IMPLIED, INCLUDING THE IMPLIED WARRANTIES OR CONDITIONS OF MERCHANTABILITY OR FITNESS FOR A PARTICULAR PURPOSE. Equipment offered by Malta Dynamics is warranted against factory defects in workmanship and materials for a period of one year from date of installation or first use by the original owner. LIMITED REMEDY: Upon notice in writing, Malta Dynamics will repair or replace all defective items at Malta Dynamics's sole discretion. Malta Dynamics reserves the right to require that the defective item be returned to its plant for inspection before determining the appropriate course of action. Warranty does not cover equipment damage resulting from wear, abuse, damage in transit, failure to maintain the product or other damage beyond the control of Malta Dynamics. Malta Dynamics shall be the sole judge of product condition and warranty options. This warranty applies only to original purchaser and is the only warranty applicable to this product. Please contact Malta Dynamics customer service department at 800-494-1840 for assistance. LIMITATION OF LIABILITY: IN NO EVENT WILL MALTA DYNAMICS BE LIABLE FOR ANY INDIRECT, INCIDENTAL, SPECIAL OR CONSEQUENTIAL DAMAGES INCLUDING, BUT NOT LIMITED TO LOSS OF PROFITS, IN ANY WAY RELATED TO THE PRODUCTS REGARDLESS OF THE LEGAL THEORY ASSERTED.