

Safety Stanchion For Concrete Horizontal Lifeline System Installation Instructions

Part Number: 00041-10

SAFETY FIRST

WARNING!

Before use of this system, read and understand all instructions, warnings, cautions and notes, etc. regarding use of the Concrete Safety Stanchion for Concrete Horizontal Lifeline.

WARNING!

The Safety Stanchion for Concrete Horizontal Lifeline is designed and tested as a system. Never use or mix components that have not been designed and tested for use with this system. Contact Safe Approach directly if you are unsure.

WARNING!

Do not attach personal fall protection equipment directly to the Horizontal Lifeline System stanchions. The wire rope on the Horizontal Lifeline assembly is the only point of attachment on the Horizontal Lifeline system for personal fall protection that is capable of minimizing fall arrest force in the event of a fall.

WARNING!

Failure to install, use and/or remove the Safety Stanchion for Concrete Horizontal Lifeline in a safe and workman-like manner can result in serious injury or death. Until the Horizontal Lifeline system is properly installed, use alternate fall protection means. Ask your supervisor for proper training.

WARNING!

The Horizontal Lifeline System allows for stanchion spacing up to 60 feet. The Horizontal Lifeline system will safely accommodate a maximum of two workers per system. Workers using the Horizontal Lifeline system must wear a full body harnesses and shock absorbing lanyards.

Never allow more than two persons on a system!

Each Standard Horizontal Lifeline system consists of:

- (2) Stanchion
- (1) Horizontal Lifeline Assembly

Each extender system consists of:

- (1) Stanchion
- (1) Horizontal Lifeline Assembly

Horizontal Lifeline assembly includes: (1) Energy Absorber assembly; (1) 1/2" x 12" jaw and jaw turnbuckle; (1) 3/8" galvanized aircraft cable – one end with double-swaged thimble, and the other with a cable thimble, (2) 1-1/2" ton safety shackles.

Step 1: INSPECTION

Inspect each stanchion and cable assembly to ensure that they were shipped as completed units and were not damaged in transit or during a previous installation.

Step 2: INSTALL STANCHIONS

Stanchions must be affixed to concrete with four (4) 3/4" diameter anchors. Anchorage system to have a minimum 9,000 pounds per anchor ultimate tension strength. Torque nuts per anchor manufacturer's instructions.

Step 3: INSTALL SAFETY STANCHION FOR CONCRETE HORIZONTAL LIFE-LINE ASSEMBLY

Completely extend the turnbuckle. Connect the Energy Absorber end of each Horizontal Lifeline assembly to a hole at the top of the center stanchion and secure bolt in each shackle with nut and cotter pin.

Connect the combination clamp/thimble end of each Horizontal Lifeline assembly to the inside hole at the top of each end stanchion and secure bolt in shackle with nut and cotter pin.

TORQUE ALL NUTS TO 45 FOOT POUNDS!

Step 4: TENSION THE HORIZONTAL LIFELINE ASSEMBLY

Pretension the cable by turning the turnbuckle body. The Horizontal Lifeline cable is to be tightened using the following chart for proper sag.

Length of System	Cable Sag
10' - 20'	1" - 2"
21' - 40'	3" - 4"
41' - 60'	5" - 6"

WARNING

The Horizontal Lifeline tension is important to the operation of the system. The tension preloads the system and allows the shock absorber to work properly.

The Energy Absorber is a single use item. It should be inspected regularly for elongation. The shock absorber is orange, there is a white band beyond the orange on the shaft. If the shock absorber is elongated and black is seen behind the white band, then the shock must be pulled from service immediately and replaced.

WARNING

If the Safety-Stanchion Horizontal Lifeline System arrests a fall, it must not be used again until it has been carefully inspected. The shock absorber is coated red. There is a white band beyond the red on the shaft. If the shock absorber is elongated and black is seen beyond the white band, then the shock absorber must be pulled from service immediately and replaced.

CAUTION

The Horizontal Lifeline assemblies are designed to be connected to and to be disconnected from the stanchions only at the safety shackles. Do not attempt to disassemble them at any other point along their length. Bolt threads have been altered and nuts have been locked into place to deter hardware removal.

If disassembled, return to Safe Approach Inc..

GENERAL WARNINGS

1. Once the stanchions have been installed, inspect them once a week by walking the line and applying moderate lateral pressure back and forth using one hand in a motion that is perpendicular to the lifelines. If any of the stanchions are found to be loose, re-torque mounting bolts.

2. The Safety Stanchion for Concrete Horizontal Lifeline system stops a fall by stretching of the cable, deflection of the posts, expansion of the inline energy absorber and extension of the user's personal shock absorbing lanyard. On a 60 foot system, this results in a fallen worker coming to rest as much as 15 feet below work level. A clear area below the workers must be maintained. Test your system with a sandbag (250 pounds) or other weight if in doubt. Use of retracting lanyard or closer spacing of the stanchions greatly reduces the fall distance.

3. Some deformation to the building structure is possible when a fall occurs. Safe Approach Inc. is not responsible for the stability or quality of the structure that the Horizontal Lifeline system is mounted on. Consult a licensed qualified engineer or Safe Approach for consultation.

4. Two people maximum on any standard Horizontal Lifeline system or extender Horizontal Lifeline system. When using this system, all personnel must use a Full Body Harness and a Shock Absorber style lanyard or self retracting lifeline.

5. Use of this device is expected to reduce the likelihood of serious injury and limit the fall distance if a fall occurs. Other means should be considered to limit the likelihood of a fall as well.

CAUTION

Once a worker has fallen, the employer must have a plan and a method to quickly rescue him/her, with treatment available and due regard given for any injury he may have sustained in the fall.

WARRANTY

The Horizontal Lifeline System is guaranteed for a period of one (1) year against defects in material or workmanship. Any modifications to the system voids the warranty.

MAINTENANCE

When not in use, store the stanchions and cable assemblies in a dry place out of the elements.

If you have any questions regarding the safe installation, and or removal of the Safety Stanchion for Concrete Horizontal Lifeline System or need additional instructions, call toll-free at (800) 471-1157

Manufactured by:
Safe Approach Inc.
206 Mechanic Falls Rd. Poland, ME 04274
(800) 471-1157 (207) 345-9900
Fax: (207) 345-9100 Email: sales@safeproach.com
(concretestanchioninstr.022609)

Bolt On Portable Lifeline Stanchion

SPECIFICATIONS

Part# 00041-10

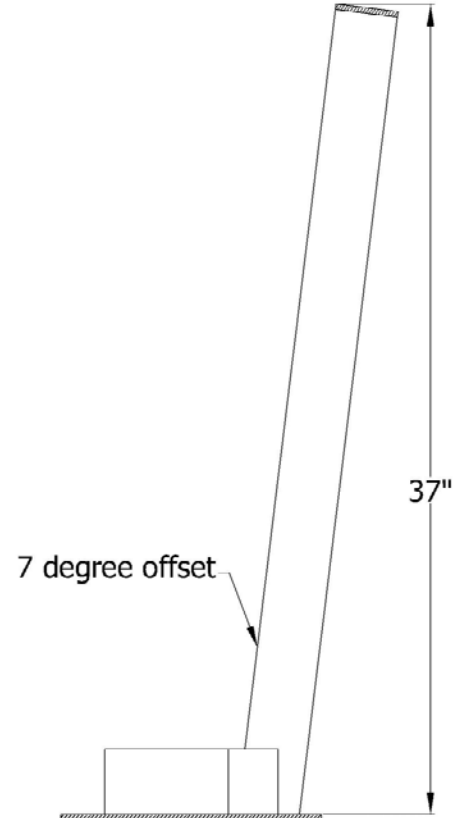
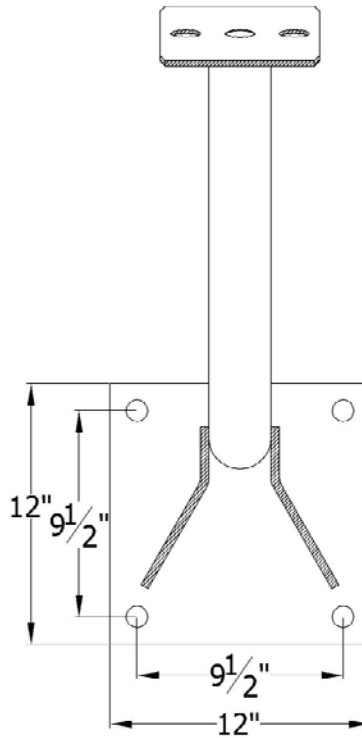

DESCRIPTION		GENERAL SPECIFICATIONS		
<p>The Safe Approach portable lifeline stanchion takes the worry out of fall protection by providing an easy to install-tie-off for multiple workers that must work at height before flooring or other fall protection is available. It can be bolted to concrete or steel structure. Minimum 1/2" x 12" flange when bolting to steel. The stanchion is designed to be used with any Safe Approach horizontal lifeline system or it may be used as a direct tie-off point for up to 2 workers utilizing a self retracting lifeline.</p>		Item	Description	Finish
		Base	A-36 Steel	Powder Coat
		Tube	2-1/2" Sch40 Steel	Powder Coat
		Concrete Anchoring—3/4" diameter anchors, minimum 9,000lb per anchor ultimate tension.		
		Steel Anchoring—3/4" diameter fasteners, Grade 5 or better.		
		Capacity—Using Safe Approach HLL system: maximum span 60', 2 workers, max weight 310 lbs/ea including tools and equipment		
		Using SRL: maximum 2 workers, max weight 310lbs/ea SRL must limit max arrest force to 1350lbs or less.		
		Technical References: Meets OSHA 1926 Subpart M		

Manufactured by Safe Approach, Inc., 206 Mechanic Falls Rd., Poland, ME 04274
 (800)471-1157, Fax (207)345-9100, www.safeapproach.com

Horizontal Lifeline System

SPECIFICATIONS

Part# P-00147-60



DESCRIPTION	GENERAL SPECIFICATIONS		
<p>This horizontal lifeline system is a two person rated lifeline when installed to proper anchorage devices. The System includes an in-line energy absorber to help reduce forces to the attaching structure. Please contact Malta Dynamics for help selecting the proper attaching hardware and to determine if your existing structure is capable of supporting a horizontal lifeline.</p>	Item	Description	Tested At
	<p>Energy Absorber</p> <p>Cable</p> <p>Shackles</p> <p>Thimbles</p> <p>Cable Clamps</p> <p>Weight-34 lbs</p> <p>Technical References: OSHA 1926.502, ANSI Z359.1</p> <p>Testing Specifications: ANSI Z359.1</p>	<p>Powder Coated Steel</p> <p>3/8" 7x19 GAC</p> <p>7/16" Galvanized Bolt Type</p> <p>3/8" Heavy Duty Galvanized</p> <p>Aluminum Machine Crimped</p>	<p>10,000 lbs.</p> <p>14,400 lbs.</p> <p>15,000 lbs.</p> <p>N/A</p> <p>N/A</p>

Manufactured by Safe Approach, Inc., 206 Mechanic Falls Rd., Poland, ME 04274
 (800)471-1157, Fax (207)345-9100, www.safeapproach.com