



**MALTA DYNAMICS**

FALL PROTECTION AND SAFETY EQUIPMENT

# Malta Dynamics Confined Space Rescue Tripod

## User Instruction Manual



**This instruction manual applies to the following models:**  
R0006

**Please read and understand the manufacturer's instructions for each component or part of the complete system. Manufacturer's instructions must be followed for proper use, care, and maintenance of this product. These instructions must be retained and be kept available for the worker's reference at all times. Alterations or misuse of this product, or failure to follow instructions, may result in serious injury or death.**

**NOTE:** The user is advised to keep the user instructions documents for the life of the product.

This manual must be read and understood in its entirety and used as part of fall protection training program as required by OSHA or any state regulatory agency. These instructions are intended to meet the manufacturer instructions as required by ANSI Z 359.4-2013. The user must fully understand the proper equipment use and limitations.

## **1. GENERAL REQUIREMENTS, WARNINGS AND LIMITATIONS:**

- The Equipment is designed for use as a part of a personal fall protection system. Components must not be used for any other operation other than that which it has been designed and approved. Fall Arrest systems are designed to comply with OSHA. Fall Restraint System must be designed by a Qualified Person, and must be installed and used under the supervision of a competent person.
- All authorized persons/users must refer to the regulations governing occupational safety, as well as applicable ANSI or CSA standards. Please refer to product labeling for information on specific OSHA regulations, and ANSI and CSA standards met by product.
- Consult a doctor if there is any reason to doubt a user's ability to withstand and safely absorb fall arrest forces. Age, fitness, health conditions can seriously affect the worker if a fall occurs. Pregnant Women and minors should not use this equipment.
- Proper precautions should always be taken to remove any obstructions, debris, material, or other recognized hazards from the work area that could cause injuries or interfere with the operation of the system. All equipment must be inspected before each use according to the manufacturer's instructions. All equipment should be inspected by a qualified person on a regular basis.
- To minimize the potential for accidental disengagement, a competent person must ensure system compatibility.
- Equipment must not be altered in any way. Repairs must be performed only by the Manufacturer, or persons or entities authorized in writing by the manufacturer.

- Any product exhibiting deformities, unusual wear, or deterioration must be immediately discarded. Any equipment subject to a fall must be removed from service. The authorized person/user shall have a rescue plan and the means at hand to implement it when using this equipment.
- Never use fall protection equipment for purposes other than those for which it was designed. Fall protection equipment should never be used for towing or hoisting.
- All synthetic material must be protected from slag, hot sparks, open flames, or other heat sources. The use of heat resistant materials is recommended in these applications.
- Never use natural materials (manila, cotton, etc.) as part of a fall protection system.
- Do not expose this equipment to chemicals which may have a harmful effect on the materials used to construct it. Be especially aware of caustic environment, or those that contain high levels of organic acids or bases. If you are uncertain about the safe operation of this equipment in any environment, contact Malta Dynamics for further instructions.
- Do not use the equipment near sharp edges, abrasive surfaces and looping around small diameter structural members.
- Do not use the equipment around moving machinery or electrical hazards.



Malta Dynamics Tripod should be used only with the combinations of components, sub-systems or both which may affect or interfere with the safe function of one another. Be certain that connecting devices are compatible and that other elements of the personal fall arrest systems are safe to use and compatible before use.

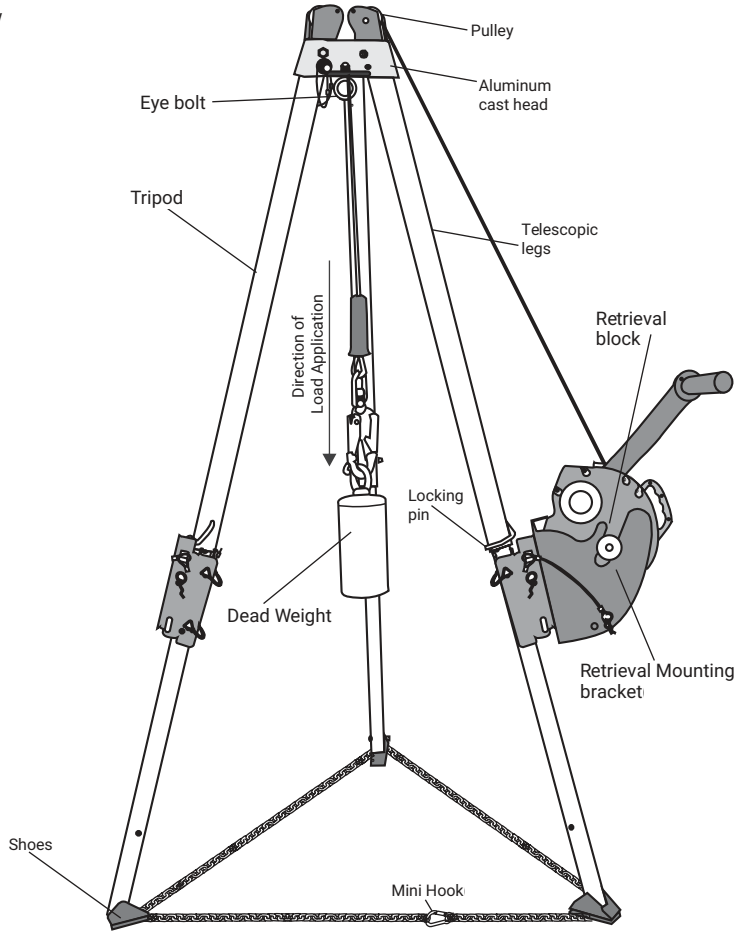

Product Over View



Brackets used with megapod variants-

Ref. No.	R0006	R0007	R0006 Bracket
Supplied with Tripod	Yes	No	No
Can be purchased separately	Yes	Yes	
Product	 <p>Part of standard Tripod</p>	 <p>Part of standard Winch</p>	

## 2. SYSTEM LIMITATIONS & REQUIREMENTS:

Consider the following limitations/requirements prior to installing or using this equipment:

- **Capacity:** Malta Dynamics Tripod is designed for use by ONE person with a combined weight (clothing, tools, etc.) of no more than 310 lbs. (140 kg) Make sure all of the components in your system are rated to a capacity appropriate to your application. Malta Dynamics Tripod is rated 5000lbs.
- **Free Fall:** Personal fall arrest systems used with this equipment must be set up to limit the free fall to 6 feet (1.8 M) per ANSI Z359.1. Restraint systems must be set up so that no vertical free fall is possible. Work positioning systems must be set up so that free fall is limited to 2 feet (.6 m) or less. Personnel riding systems must be rigged so that no vertical free fall is possible. Climbing systems must be rigged so that free fall is limited to 18 inch. (.46 cm) or less. Rescue systems must be rigged so that no vertical free fall is possible. See subsystem manufacturer's instructions for more information. Below figure illustrates fall clearance requirements. There must be sufficient clearance below the user to allow the system to arrest a fall before the user strikes the ground or other obstruction. Clearance required is dependent on the following factors:

- Elevation of Anchorage
- Connecting Subsystem Length
- Deceleration Distance
- Free Fall Distance
- Worker Height

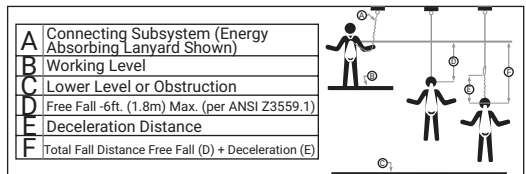

### Movement of Harness Attachment Element

- **Swing Falls:** Swing falls occur when the anchorage point is not directly above the point where a fall occurs. The force of striking an object in a swing fall may cause serious injury or death. Minimize swing falls by working as close to the anchorage point as possible. Do not permit a swing fall if injury could occur. Swing falls will significantly increase the clearance required when a self-retracting lifeline or other variable length connecting subsystem is used.

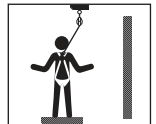

- **Environmental Hazards:** Use of this equipment in areas with environmental hazards may require additional precautions to prevent injury to the user or damage to the equipment. Hazards may include, but are not limited to; heat, chemicals, corrosive environments, high voltage power lines, gases, moving machinery, and sharp edges.



# CONNECTOR COMPATIBILITY LIMITATIONS

Malta Dynamics' equipment must be coupled only to compatible connectors that are suitable to your application. Ensure all connections are compatible in size, shape, and strength. Ensure all connectors are fully closed and locked. OSHA 29 CFR 1926.502 prohibits the use of snap hooks to engage objects unless the following requirements are met:

- Snap hook must be a locking model.
- Snap hook must be explicitly designed for such a connection.

Use of a non-locking snap hook can result in rollout (a process by which a snap hook or carabiner unintentionally disengages from another connector or the object to which it is coupled (ANSI Z359.0-2007). Malta Dynamics connectors (snap hooks and carabiners) are designed to be used only as specified in each product's user's instructions.

## **Avoid the following types of connections:**

- Two or more snap hooks or carabiners attached to one D-Ring.
- A snap hook connected to its integral lanyard.
- A snap hook connected to a horizontal lifeline.
- Connection in a manner that results in a load on the gate. NOTE: *Large throat opening snap hooks should not be connected to standard size D-Rings or similar objects, as such use will result in a load on the gate if the hook or D-Ring twists or rotates. Large throat snap hooks are designed for use on structural elements such as rebar or cross members that are not shaped in such a way that they may capture the gate of the hook.*
- False engagement connections, where protruding features of the snap hook or carabiner may catch on the anchor and seem fully engaged to the anchor point. Always confirm engagement.
- Connection to snap hooks or carabiners.
- Direct connection to webbing lanyard, webbing loop, rope lanyard or tie-back (unless the manufacturer's instructions for both the lanyard and connector specifically allow such a connection).
- Malta Dynamics' Full Body Harnesses shall be used as part of a personal fall arrest system that limits the maximum free-fall distance to six feet (1.8 m). If used with appropriate connecting systems, the Full Body Harnesses may be used with free falls exceeding six feet (1.8m)
- Full Body Harnesses shall only be used as part of a work positioning system that limits the maximum free-fall distance to two feet (0.6 m).
- Personal Energy Absorbers and Energy Absorbing Lanyards marked with, "ANSI Z359.13," and "Six-Foot Free Fall" are designed for up to six feet. Free-fall applications have a maximum capacity of 310 pounds. (141 kg) including clothing, tools, etc.



- Not all fall protection components are rated for the same user weight capacity. ONLY use components rated for the same weight capacity.
- This equipment is designed to be used in temperatures ranging from -40°F to +130°F (-40°C to +54°C).
- Connection of a snap hook to a D-Ring, rebar, or other connection point of improper dimensions in relation to the snap hook dimensions or configurations that could cause the snap hook keeper to be depressed by a turning motion of the snap hook, or such that snap hook or carabiner will not fully close and lock, or that roll-out could occur.
- **Illustration 3** depicts examples of inappropriate connections:

### Illustration 3: Inappropriate Connections



**NOTE:** Other than 3,600 lb. (16 kN) gated hooks, large throat opening snap hooks should not be connected to standard size D-rings or similar objects which will result in a load on the gate if the hook or D-ring twists or rotates. Large throat snap hooks are designed for use on fixed structural elements such as rebar or cross members that are not shaped in a way that can capture the gate of the hook.

#### 4. CONNECTING SUB-SYSTEMS:

Personal fall arrest systems used with this equipment must meet applicable state, OSHA and ANSI requirements. A full body harness must be worn when this equipment is used as a component of a personal fall arrest system. As required by OSHA, the personal fall arrest system must be capable of arresting the user's fall with a maximum arresting force of 1,800 lbs. (8 kN), and limit the free fall to 6 ft. (1.8 m) or less.

- **Rescue Plan:** Rescue operation must be performed by the trained and competent personal. The rescue operation must be performed under the supervision of the rescue expert team or personal. It is advised that while working on site work in pairs. Before going for the work the user must have the rescue plan according to the work.



- **If Equipment Is Subjected To A Fall:** Remove the equipment from service immediately if it has been subjected to the forces of a fall arrest. Contact your distributor or Malta Dynamics about policies regarding replacement of Malta Dynamics components involved in a fall.

## 5. SPECIFIC INSTRUCTIONS:

Malta Dynamics Anchors are designed to provide complete attachment system to user in the event of a fall. These attachment systems must be connected to the proper body support and connecting facility. These Anchors are meant to hold the victim of fall till the rescue operation is performed, so this is important that the whole system must have the all the essential components before going for the use. The whole fall arrest system must be used by the trained/competent person. It is advisable to make a checklist of the essential components according to one's use before going for work.

## 6. USE OF FALL ARREST SYSTEM:

The fall arrest system **MUST ONLY** be connected to the back attaching element on the harness provided for the purpose ("D" ring or webbing attachment extension) or to the chest anchorage points ("webbing link" or "D" link). The chest anchorage points must imperatively be used together. The D-rings on the belt and the ventral anchorage point must only be used for the attachment of a work positioning or retaining system and never with a fall arrest system. During use, check regularly the adjustment and/or attachment points.

**7. ANCHORAGE STRENGTH:** The anchorage strength required is dependent on the application type. The following are the requirements of ANSI Z359.1 for these application types:

- **Fall Arrest:** Anchorages selected for fall arrest systems shall have a strength capable of sustaining static loads applied in the directions permitted by the system of atleast- (1) 5,000 lbs.(23kN) for non-certified anchorages, or (2) Two times the maximum arresting force for certified anchorages. When more than one fall arrest system is attached to an anchorage, the strengths set forth in (1) and (2) above shall be multiplied by the number of systems attached to the anchorage.

**As Per OSHA:** Anchorages used for attachment of personal fall arrest systems shall be independent of any anchorage being used to support or suspend platforms and capable of supporting at least 5,000 lbs.(23kN) per user attached, or be designed, installed and used as part of a complete personal fall arrest systems which maintains a safety factor of at least two, and is under the supervision of a qualified person.

- **Work Positioning:** The structure to which the work positioning system is attached must sustain static loads applied in the directions permitted by the work positioning system of at least 3,000 lbs. (13.3 kN) or twice the potential impact load, whichever is greater. See OSHA. When more than one work positioning system is attached to an anchorage, the strengths stated above must be multiplied by the number of work positioning systems attached to the anchorage.
- **Restraint:** Anchorages selected for restraint and travel restraint systems shall have a strength capable of sustaining static loads applied in the directions permitted by the system of at least: (1) 1,000 lbs. (4.5 kN) for non-certified anchorages, or (2) Two times the foreseeable force for certified anchorages. When more than one restraint and travel restraint system is attached to an anchorage, the strengths set forth in (1) and (2) above shall be multiplied by the number of systems attached to the anchorage.
- **Rescue:** Anchorages selected for restraint and travel restraint systems shall have a strength capable of sustaining static loads applied in the directions permitted by the system of at least: (1) 3,000 lbs. (13.3 kN) for non-certified anchorages, or (2) Five times the foreseeable force for certified anchorages. When more than one restraint and travel restraint system is attached to an anchorage, the strengths set forth in (1) and (2) above shall be multiplied by the number of systems attached to the anchorage.

ANCHORAGE & ANCHORAGE STRENGTH: Anchorage and anchorage strength requirements are dependent on the Full Body Harness. In accordance with ANSI Z359.1, anchorages selected for fall Arrest Systems must meet the anchorage strength requirements defined in below:

#### Anchorage Strength Requirements

<b>Fall Arrest<sup>1</sup></b>	Non-Certified Anchorage:	5,000 lbs. (23kN)
	Certified Anchorage <sup>2</sup> :	2 Times the Maximum Arresting Force for Certified Anchorage
<b>Restraint<sup>1</sup></b>	Non-Certified Anchorage:	1,000 lbs. (4.5kN)
	Certified Anchorage <sup>2</sup> :	2 Times the Foreseeable Force for Certified Anchorage
<b>Work Positioning<sup>1</sup></b>	Non-Certified Anchorage:	3,000 lbs. (13.3kN)
	Certified Anchorage <sup>2</sup> :	2 Times the Foreseeable Force for Certified Anchorage
<b>Rescue<sup>1</sup></b>	Non-Certified Anchorage:	3,000 lbs. (13.3kN)
	Certified Anchorage <sup>2</sup> :	5 Times the Foreseeable Force for Certified Anchorage
<b>Climbing</b>	The structure which a climbing system is attached must sustain the loads required by that particular system. See the instructions for the climbing system for requirements.	

**1 Multiple Systems:** When more than one of the defined system is attached to an anchorage, the strength defined for Non-Certified or certified anchorage shall be multiplied by the number of systems attached to the anchorage.

**2 Certified Anchorage:** An anchorage for fall arrest, positioning, restraint, or rescue systems that a qualified person certifies to be capable of supporting the potential fall force that meet the criteria for a certified anchorage prescribed in this standard.



## 8. INSPECTION:

Before each use, proceed with a thorough visual examination to ensure that the PPE is intact (the same applies to the equipment used with the harness (connectors, lanyard) and take all necessary steps concerning the implementation of rescue in total safety. In the event of your product gets contaminated, consult the manufacturer or authorized agent. If you have any doubts regarding the safe state of the product or if the product has been used to arrest a fall, it is essential to immediately withdraw the PPE from use and send it to the manufacturer or a qualified repair center for checking or destruction.

Following the inspection, the center will provide written authorization or refusal for the use of the PPE. Never attempt to modify or repair PPE.

- Before each use of this equipment inspect it according to the following guidelines: A formal inspection of fall protection products/components must be performed at least every six months by a competent person other than the user. The frequency of formal inspections should be based on conditions of use or exposure. Record the inspection results in the inspection and maintenance log at the end of this manual. The component should be checked for Cut, Frayed, Heavily Soiled, welding burns etc. Metal parts like D-rings should be duly check for the crack, bent, deformities, corrosions etc.

## 9. LIMITATIONS:

- Tripod should be a personal property of its user.
- It should not be used in highly acidic or basic environments.

## 10. FITTING & SIZING:

The Tripod comes in two variants i.e. 7ft.(2.10) and 10ft (3.05). Depending on the condition of usage one can choose best option as per requirement.

**STEP 1:** Place the Tripod on the floor with the feet on the ground. Remove the locking Pins from the head and the legs.

**STEP 2:** Fully spread the legs and then replace the locking pins on head to secure the legs in the open positions.

**STEP 3:** Resecure the locking pins into legs, after adjustment of the required height or in fully extended position.

**STEP 4:** Place the Tripod over the entry point. Adjust the Tripod as necessary by removing pins in one leg at a time. Adjust each leg so the Tripod sits level above user's entry point. Ensure that all pins are re-installed.

**STEP 5:** Place the Retrieval Block on the opposite leg of the Tripod, where the winch is installed.

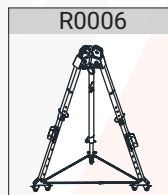
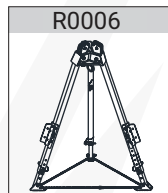

## 11. FALL CLEARANCE:

If there is a risk of fall or if the only anchorage is below the attachment points on the harness, it is essential to use a lanyard provided with an energy absorber. Before using a shock-absorbing lanyard, check that there is sufficient fall clearance below the user to prevent any collision with the structure or the ground.

## 12. MATERIAL & CONSTRUCTION:

- **Materials:** High Strength Aluminium

- **System Requirements:**

- **Compatibility of Components:** Malta Dynamcis Fall Protection equipment is designed to be used with Malta Dynamcis approved components. Please contact Malta Dynamcis if you have a question regarding compatibility. Making substitutions without approval from Malta Dynamcis Fall Protection may lead to injuries and or death. A Qualified person can make a determination on compatibility of equipment from different manufacturers.

- **Compatibility of Connectors:**

Connectors (D-rings, hooks, carabiners) must be capable of supporting at least 5,000 lbs. (23kN). Do not use equipment that is not compatible. Non-compatible connectors may unintentionally disengage. Self-locking snap hooks and carabiners are required by CSA, ANSI and OSHA. Connectors must be compatible in size, shape, and strength.

- **Making Connections:** Only use self-locking snap hooks and carabiners with any Malta Dynamics Fall Protection equipment. Do not use equipment that is not compatible.

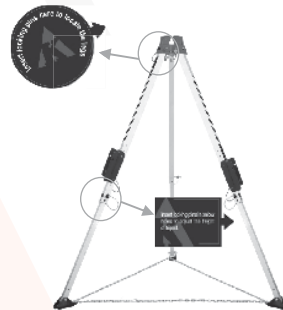

## Installation of retrieval block on megapod:

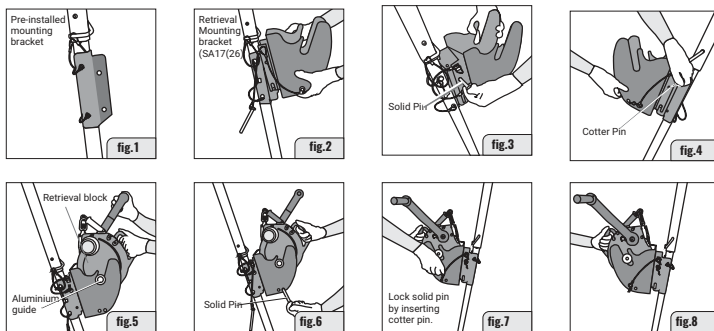

**STEP 1** Locate the Tripod leg that has pre-installed mounting bracket for installing the retrieval block.

**STEP 2** Place the retrieval mounting bracket on the lower mounting bracket pre-installed on the Tripod leg and insert the guiding pin into the slot. (refer fig. 2 and 3)

**STEP 3** Use solid pin for locking the Retrieval Mounting bracket on pre-installed mounting bracket of Tripod leg. (refer fig. 4)

**STEP 4** Lock the solid pin on mounting brackets using cotter pin. (refer Fig. 4)

**STEP 5** Insert retrieval block in bracket guided by aluminum guide provided on both side of retrieval. (refer Fig. 5)

**STEP 6** Lock the anchorage eye with bracket followed by solid pin and lock solid pin from other end by inserting cotter pin. (refer fig. 6&7). Now the retrieval block is ready to be used on Tripod (refer fig. 8)

## 13. OTHERS:

- **Maintenance & Cleaning:** Repairs to equipment can be made only by a Malta Dynamics representative or person or entity authorized by Malta Dynamics. Contact Malta Dynamics for maintenance and repair. Cleaning after use is important for maintaining the safety and life of the equipment. Cleanse the equipment of all dirt, corrosives, and contaminants. If the equipment cannot simply be wiped clean use a mild soap and water. Rinse, wipe, and hang to dry in shade.

- **Storage:** Store the anchorage connector harness in a cool, dry and clean place out of direct sunlight. Avoid areas where heat, moisture, light, oil, and chemicals or their vapors or other degrading elements may be present. Equipment which is damaged or in need of maintenance should not be stored in the same area as usable equipment. Heavily soiled, wet, or otherwise contaminated equipment should be properly maintained (e.g. dried and cleaned) prior to storage.

Prior to using equipment which has been stored for long periods of time, a Formal Inspection should be performed by a competent person. For harnesses with Dielectric buckles, pass-thru buckles or Quick Connect Buckles, store the harness with the buckles connected.

- **Training:** It is the responsibility of the users to assure that they read, understand, and follow all instructions and are trained in the care and use of this device. Training should be repeated periodically and any time there is a change of components within the system. Training must be conducted without exposing the trainee to a fall hazard





# WARRANTY

The following warranty is made in lieu of all warranties or conditions, whether expressed or implied. This includes the implied warranties or conditions of merchantability or fitness for a particular purpose.

Equipment offered by Malta Dynamics is warranted against factory defects in workmanship and materials for a period of one year from date of installation or first use by the original owner.

**LIMITED REMEDY:** Upon notice in writing, Malta Dynamics will repair or replace all defective items at Malta Dynamics's sole discretion. Malta Dynamics reserves the right to require that the defective item to be returned to its plant for inspection before determining the appropriate course of action.

This warranty does not cover equipment damage resulting from wear, abuse, damage in transit, failure to maintain the product or other damage beyond the control of Malta Dynamics. Malta Dynamics shall be the sole judge of product condition and warranty options. This warranty applies only to the original purchaser and is the only warranty applicable to this product. Please contact Malta Dynamics customer service department at 800-494-1840 for assistance.

**LIMITATION OF LIABILITY:** IN NO EVENT WILL MALTA DYNAMICS BE LIABLE FOR ANY INDIRECT, INCIDENTAL, SPECIAL OR CONSEQUENTIAL DAMAGES— INCLUDING, BUT NOT LIMITED TO—LOSS OF PROFITS IN ANY WAY RELATED TO THE PRODUCTS, REGARDLESS OF ANY LEGAL THEORY ASSERTED.





800-494-1840  
MaltaDynamics.com  
210 13th Street  
Malta, OH 43758 USA